

# **Field work instructions 2021**

# **RIS**

**Riksinventeringen av skog**

**Swedish National Forest Inventory  
Swedish Soil Inventory**



**SLU  
INSTITUTIONEN FÖR SKOGLIG RESURSHUSHÅLLNING  
901 83 UMEÅ  
och  
INSTITUTIONEN FÖR MARK OCH MILJÖ  
Box 7014, 750 07 UPPSALA**

**N.B! All page numbers in tables of content and indexes not updated**

# 1 GENERAL

This instruction applies to field work 2021 at the *National Forest Inventory* (RT). RT is an annual inventory of Sweden's forests and forest land, with the aim of describing conditions and changes, and providing data as a basis for forecasts of the development of forests and soil conditions. The inventory includes a large number of elements to describe the forests from both a production and an environmental perspective.

RT is carried out as a sample inventory. The entire surface area of Sweden is covered by a systematic network of so-called inventory tracts. Each tract consists of a number of sample plots laid out in a rectangular or square pattern. Some registrations are carried out on all sample plots. To the extent that all sample plots of a tract fall within land use classes such as *freshwater, developed land, arable land, etc.*, only a more general description is made by so-called map assessment (data are taken from e.g. maps and aerial photographs for sample plots that are not observed on-site). The same applies to sample plots that are classified as *high mountains* and are located at high altitudes, so-called *high mountains*. Other sample plots are observed on-site. In particular, the condition of sample plots in the land use classes *productive forest land, natural pasture, morass, rock and certain other impediments, Subalpine coniferous woodland* and *high mountains* (sample plots defined as low mountain) is described in detail. The sample consists of a combination of temporary and permanent sample plots, as this offers the best possibility of monitoring both conditions and changes with a high level of precision. The permanent sample plots are re-inventoried at 5-year intervals - different for different inventory items.

RT data is used in a variety of ways. One important area concerns reporting to international conventions and other agreements. Nationally, the data are used for community planning in a broad sense. Authorities use the data for analyses of forest, environment and energy policies. Important examples include regular monitoring and evaluation of forest policy and environmental objectives. Forestry companies and professional organisations use the data in their overall planning and analyses. The data

are also central to forest and environmental research. In some analyses, field measurements are combined with remote sensing, primarily to improve the precision of descriptions in smaller geographical areas.

Many data from RT are included in Sweden's official statistics, which implies special quality requirements. RT is mainly funded by SLU and SLU is responsible for its implementation.

Further reading:

See the website of the National Forest Inventory:

<https://www.slu.se/en/Collaborative-Centres-and-Projects/the-swedish-national-forest-inventory/>

## **1.1 LAYOUT OF THE INSTRUCTION**

Initially, technical instructions are given for the implementation of the fieldwork. This is followed by a longer section in which different parts of the inventory are described step by step. The descriptions are given collectively with the ambition to refer only to a minor extent to the appendix for detailed instructions. The structure of the field instruction follows the structure of the data collection given by the program in the field computer ("Skog&Mark", abbreviated S&M).

For each variable to be registered, the instruction starts with a variable name (usually an abbreviation) and an explanation thereof. The codes for the variable are then given. Finally, definitions and instructions for the implementation of the measurements are given.



## 2 TECHNICAL INSTRUCTIONS

The Chapter includes:

| Section   | See<br>page |
|---|-------------|
| 2.1 The Inventory Team .....  | 2:2         |
| 2.2 Regions.....  | 2:2         |
| 2.3 Tracts .....  | 2:2         |
| 2.4 Sample plots.....   | 2:4         |
| 2.5 On-site visits to sample plots .....  | 2:6         |
| 2.6 Terrain marking and documentation<br>of sample plots.....   | 2:7         |
| 2.7 Unit of action, divergent part, stand and<br>area requirements for different land use classes ... | 2:9         |
| 2.8 Delimitation of impediment .....  | 2:11        |
| 2.9 Splitting .....   | 2:13        |
| 2.11 Control of data .....  | 2:17        |

## **2.1 THE INVENTORY TEAM**

During the 2021 field season, the number of regular assessment teams will be sixteen. Six of the teams work with only temporary survey tracts and permanent tracts without soil inventory. The other ten teams work on all types of tracts, temporary and permanent with and without soil inventory.

The assessment team consists of a team leader and two research assistants. When working on permanent tracts with soil inventory, one of the assistants works as a soil surveyor. The soil surveyor also has the principal responsibility for the ground vegetation description.

## **2.2 REGIONS**

The country is divided into five regions. These are delineated according to the map on the next page, see figure 2.

## **2.3 TRACTS**

The registrations are made on sample plots located along the sides of the so-called tracts. There are two types of tracts, temporary (T-tracts) and permanent (P-tracts). These have different designs. In addition, the design varies between regions. The tract is a unit of work, which should normally be completed in one day. However, temporary tracts in region 4 and all tracts in region 5 are so-called "half-day tracts". Of these, normally 2 tracts per day should be managed. Temporary tracts are designed as vertical rectangles and permanent tracts as squares. A point, e.g. the centre of a sample plot, on the tract is defined not only by the tract number (shown on the working map) but also by the side (N, E, S, W) and the centrepoint of sample plot. The centrepoint of sample plot means the distance in metres to the point from the nearest preceding corner of the tract in a clockwise direction around the tract.

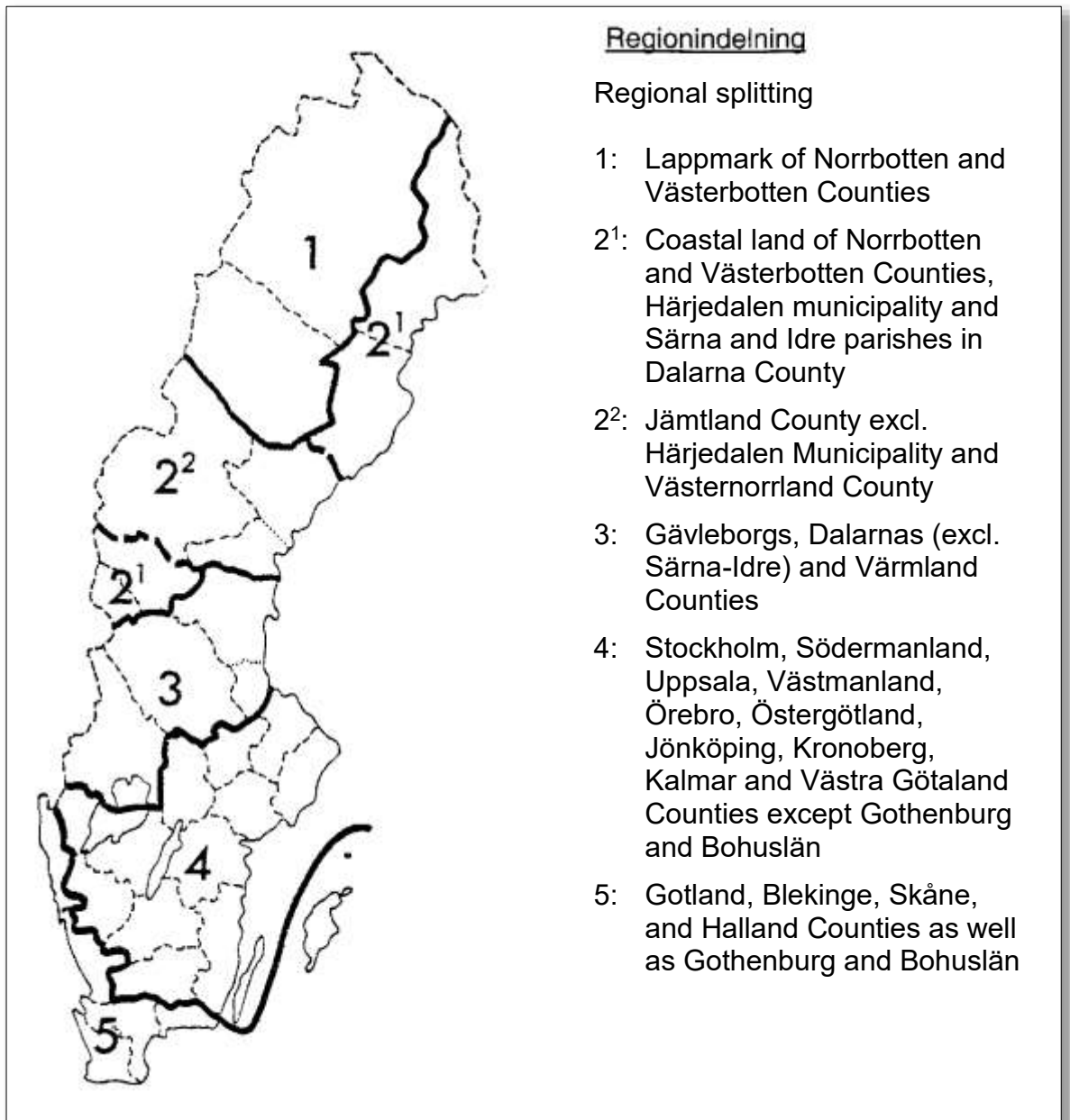

**Fig. 2.1** *Regional splitting.*

On half of the permanent tracts, *soil inventory* and *vegetation inventory* are carried out. These tracts are referred to as **P<sub>M</sub>** tracts. Other permanent tracts are referred to as **P<sub>ö</sub>** tracts and temporary tracts are referred to as **T**-tracts. The tract type is shown in the field teams' working maps.

In tracts with the land use class *high mountains*, only centrepoint of sample plot defined as *low mountains* are surveyed, the centrepoint of sample plot to be inventoried are shown in the tract map. If a tract is divided by a regional border, the tract map shows centrepoints of sample plots to inventory.

## 2.4 SAMPLE PLOTS

The sample plots to be inventoried are shown in the tract map and the Allegro3 handheld fieldcomputer. These sample plots must be inventoried even if they, when located, is in a different position than the theoretical. Sample plots that, according to the records, should not be inventoried, should never be inventoried regardless of where they end up when located and should therefore not be visited.

Sample plots are inventoried along the sides of the tracts, and are posted in certain positions. Depending on the type of tract, the following types of sample plots occur:

| <b><i>Temporary tracts</i></b>                   | <b><i>Permanent tracts</i></b>                    |
|--|---|
| Temporary volume reserve plots<br>(radius 7.0 m) | Permanent volume reserve plots<br>(radius 10.0 m) |
| Stump plots<br>(radius 7.0 m)                    | Stump plots<br>(radius 7.0 m)                     |

Förrådsytor inventeras alltid, medan mellanliggande ytor endast inventeras i de fall då ytan berörs av en avverkning som skett under säsong 1.

Volume reserve plots are always inventoried, while stump plots are inventoried only in cases where the plot is affected by a felling that has taken place during season 1.



2.4 Technical instructions - Sample plots

**Tab. 2.2** The size of the tracts and the location of the different sample plots(m).

| <b>Reg.</b> | <b>Temporary tracts</b> |                |                   |               | <b>Reg.</b> | <b>Permanent tracts</b> |                  |                |               |   |
|-------------|-------------------------|----------------|-------------------|---------------|-------------|-------------------------|------------------|----------------|---------------|---|
|             | Side<br>m               | Sample<br>plot | Volum-<br>-e plot | Stump<br>plot |             | Side,<br>m              | Sampl-<br>e plot | Volume<br>plot | Stump<br>plot |   |
| <b>1-3</b>  | 1500                    | 200            |                   | X             | <b>1-2</b>  | 1200                    | 300              |                | X             |   |
|             | (Ö,V)                   | 500            | X                 |               |             |                         | 600              | X              |               |   |
|             |                         | 700            |                   | X             |             |                         | 900              |                |               | X |
|             |                         | 1000           | X                 |               |             |                         | 1180             | X              |               |   |
|             | 1000                    | 1200           |                   | X             |             |                         |                  |                |               |   |
| (N,S)       | 1500                    | X              |                   |               |             |                         |                  |                |               |   |
| <b>4</b>    | 800                     | 200            |                   | X             | <b>3</b>    | 1000                    | 200              |                | X             |   |
|             | (Ö,V)                   | 400            | X                 |               |             |                         | 500              | X              |               |   |
|             | 400                     | 600            |                   | X             |             |                         | 700              |                |               | X |
|             | (N,S)                   | 800            | X                 |               |             |                         | 980              | X              |               |   |
| <b>5</b>    | 600                     | 100            |                   | X             | <b>4</b>    | 800                     | 200              |                | X             |   |
|             | (Ö,V)                   | 300            | X                 |               |             |                         | 400              | X              |               |   |
|             | 300                     | 400            |                   | X             |             |                         | 600              |                |               | X |
|             | (N,S)                   | 600            | X                 |               |             |                         | 780              | X              |               |   |
|             |                         |                |                   |               | <b>5</b>    | 300                     | 100              |                | X             |   |
|             |                         |                |                   |               |             |                         | 280              | X              |               |   |

## 2.5 ON-SITE VISITS TO SAMPLE PLOTS

The easiest way to the sample plot is found with the help of the GPS and a regular compass. There is no requirement to follow a straight line. When just over 20 meters from the sample plot, depending on, among other things, the tract type:

On volume sample plots on permanent tracts, which have been previously examined, GPS can be used for navigation right up to the centre of the sample plot.

On stump plots where it is quite obvious that no inventory should take place, e.g. on impediment, GPS can be used for navigation right up to the sample plot centrepoint.

On volume sample plots in permanent tracts that have never before been field-inventoried, all volume sample plots in temporary tracts, as well as stump plots where it is observed that stump inventory may be relevant, compass and tape measure are used for navigation for the last 20 meters up to the sample plot centrepoint. From the GPS receiver, information about distance and direction is given to the relevant sample plot centrepoint. This procedure is absolutely of the outmost importance to avoid a high risk of systematic errors.

If the GPS receiver loses satellite contact during navigation, one of the following is done:

1. If far from the sample plot centrepoint, continue with rough compass walking until satellite contact is resumed.
2. If close to the sample plot centrepoint, move to a point where, depending on local conditions, contact can be resumed. From this point, compass and tape measure are used to reach the plot centre. Alternatively, a new starting point is sought in the terrain that can

be identified on the map. From this point, a compass and tape measure are used to reach the surface centre.

If for some reason the GPS receiver cannot be used (broken, lost, etc.), the objective is that the plot centre for temporary volume plots and stump plots should be established in accordance with the position according to the work map. The approach should be adapted to the conditions but be based on as accurate orientation in the map image as possible. Clearly distinguishable starting points in the work map are used, and compass walking and measurement with tape measure are used in the last 20 meters.

## **2.6 MARKING IN THE TERRAIN AND DOCUMENTATION OF SAMPLE PLOTS**

The centre for volume reserve plots and stump plots on temporary tracts, as well as permanent stump plots, is marked with a wooden stick. These sticks should be left behind.

In previously field-inventoried permanent tracts, the centre for volume reserve plots is marked with aluminium profiles or carved crosses in rock. The aluminium profile normally sticks up to a maximum of 20 cm. On pasture and also in other places where it can cause damage, it is completely knocked down into the ground. In some cases, the aluminium profile has not been knocked down in the plot centre but elsewhere within the sample surface.

Volume reserve plots on not previously field-inventoried permanent tracts shall be marked with an aluminium profile or carved cross in rock.

On permanent sample plots there are normally two fixed points described in the Fixed Points menu (see example later). In cases where the aluminium profile is not knocked down in the centre, it is described as an additional fixed point. During the re-inventory, fixed points are checked and improved and, if necessary, new ones are made.

Terrain objects that differ as much as possible from the surroundings are chosen as fixed points. As far as possible, trees should be avoided. Note that if the aluminium profile or carved cross has been placed in a position other than the plot centre, this should be indicated in the Fixed Points menu by selecting Fixtype = "Aluminium Profile". In these cases, it should be knocked down at a distance from the plot centre in order to avoid the risk of it being confused with a centre profile.

On permanent volume plots, the centres of the two small plots within the sample plot (see section 7.2 and figure 7.3) are marked with a blue plastic stick. If, upon re-inventory, only one blue stick is found, the other is re-installed based on the recovered stick. If no stick is found, new ones are installed with the guidance of figure 7.3

All permanent volume sample plots, regardless of the land use class, shall be described with fixed points if there is a need to clarify the location of the plot centre. Where possible, the plot centre or a point in the vicinity of the plot centre shall be marked.

If the volume sample plot is located on a high mountain land use class and is visited in the field, the plot centre must be marked and documented in the menus Location of plot centre and Fixed Points.

In some cases, previously unmarked plot centres in permanent volume reserve plots may not need to be marked due to a change in land use class.

## **2.7 MANAGEMENT UNIT, DEVIATING PART, STAND AND AREA REQUIREMENTS FOR DIFFERENT LAND USE CLASSES**

In the case of forestry planning, the productive forest land is divided into somewhat uniform areas in terms of maturity, site conditions, age and tree species composition. In these areas, the intended future forestry action must be the same. In traditional forest description, these so-called action units or compartments were quite large. Within the action units, there could be smaller areas with an anomalous level of development, which were said to be an anomalous part, or part of the action unit.

Better advance information in the form of remotely sensed data now allows forests to be divided into smaller, more homogeneous areas. The classification criteria are the same as before, but the description is made so that there is less variation within the stocks within the described areas.

In connection with the National Forest Inventory the productive forest land is “divided” in the vicinity of the sample plot centrepoint. The action units are not drawn up in advance, but the description and delimitation are determined on site in connection with the inventory. The split is carried out regardless of the owner, ownership boundaries or any forms of protection. Usually the area, the description unit, for which the Swedish National Forest Inventory draws up its description of the stand, coincides with what in a traditional classification would constitute an action unit, but sometimes the description unit is smaller. An action unit has no predetermined minimum size. The decisive factor is whether, for an area that is in some sense homogeneous, it is considered justified to carry out a given operation at a given time, so that the combination of type of operation and timing of the operation clearly differs from what applies to neighbouring areas.

The assessment must also take into account the type of forest management carried out in the surrounding landscape.

In some cases, the sample plot may be included in a part that is smaller

2.7 Technical instructions –  
Action unit, anomalous part, stocks and area requirements  
for different land use classes.

than and *anomalous* from the action unit. If the degree of development for this part differs from the degree of development applicable to most of the action unit and if the anomalous part meets the minimum requirements (see below), it must be described as its own unit of description.

→ *Please note that differences in e.g. tree species composition, site productivity, site index, etc. do not affect the assessment in these cases, but only differences in the degree of development are considered.*

In order to form its own description unit, the area of the stand must be at least 0.02 ha at a higher rate of development than for the action unit and at least 0.1 ha at a lower rate of development than the action unit. Furthermore, the degree of development of the stand must differ from the action unit to the extent that the stand description is greatly affected. The following table can be used to support the assessment of the size of the anomaly.

**Tab. 2.3** Degree of development of anomalous part per cutting class.

| <b>Maturity Class for action unit</b> | <b>Degree of development of anomalous part</b> |              |           |              |           |              |
|---------------------------------------|--|--------------|-----------|--------------|-----------|--------------|
|                                       | <b>A1</b>                                      | <b>B1-B2</b> | <b>B3</b> | <b>C1-C2</b> | <b>C3</b> | <b>C4-D2</b> |
| <b>A1</b>                             |  |              | <b>X</b>  | <b>X</b>     | <b>X</b>  | <b>X</b>     |
| <b>B1-B2</b>                          |  |              |           | <b>X</b>     | <b>X</b>  | <b>X</b>     |
| <b>B3</b>                             |  |              |           |              | <b>X</b>  | <b>X</b>     |
| <b>C1-C2</b>                          | <b>X</b>                                       | <b>X</b>     |           |              |           | <b>X</b>     |
| <b>C3-E1</b>                          | <b>X</b>                                       | <b>X</b>     | <b>X</b>  |              |           |              |

Units with different land use classes must be distinguished and described if they meet the following minimum size requirements:

- Productive forest land within other land use classes: 0.25 ha (50x50 m).

2.7 Technical instructions –  
Action unit, anomalous part, stocks and area requirements  
for different land use classes.

- Other land use classes within productive forest land: 0.02 ha (10x20 m).
- Different types of other land use classes within or next to each other: 0.25 ha.
- Developed land: No minimum requirement.

## 2.8 DELIMITATION OF IMPEDIMENT

The site productivity system is designed for determining the site productivity of productive forest land, i.e. land where the site productivity with respect to the most high-producing tree species is at least 1 m<sup>3</sup>fo per ha per year. This production figure refers to 100 years of growth and is therefore not directly comparable to site productivities indicated for different stand indices. Normally, only pine and spruce are taken into account. The system is weakly substantiated for the lowest site productivities and can only be used in certain situations for the demarcation between impediment and productive forest land. The difficulty of such a demarcation largely depends on the type of impediment. We distinguish between the following three types:

### Treeless impediment

E.g. high mountains above the tree line, bare bogland and bare rock-bound land. Usually, it is easy to distinguish such impediments from productive forest land.

### Homogeneous, wooded impediments

Land with relatively constant supply of water and nutrition over the area. Trees are present. Examples of this type of impediment are the so-called Subalpine coniferous woodland, i.e. climatically conditioned impediments between the boundary of productive forest land and the tree line. Wooded bogland can also be included. On the homogeneous wooded

## 2.8. Technical instructions — Delimitation of impediment

impediments, the site productivity system can sometimes be used to support descisions. In this respect, the impediment boundary corresponds to approximately a site index of 10 m for pine and spruce.

If there is a stand, which is at least about 60 years of age at breast height, additional support for the boundaries can be obtained by roughly estimating the average growth up to the time of estimation. The following method is used for this purpose.

Estimate with relascope the total basal area per ha for living, dead and cut trees. Assess the latter via stumps. Calculate the basal area-weighted average height of the stand and estimate the volume. Divide the volume by the total age of the stand, i.e. breast height age plus a flat-rate supplement for growing time to 1.3 m height. The annual growth obtained is multiplied by a correction factor of the order of 1.25-2.00. An estimate of the ideal annual average growth is obtained.

The correction factor should, among others, compensate for the fact that growth is often lower than at the age of 100, that some of the volume produced is likely to be missed and that the stand is unlikely to be ideal. The value of the correction factor must be assessed by local experience

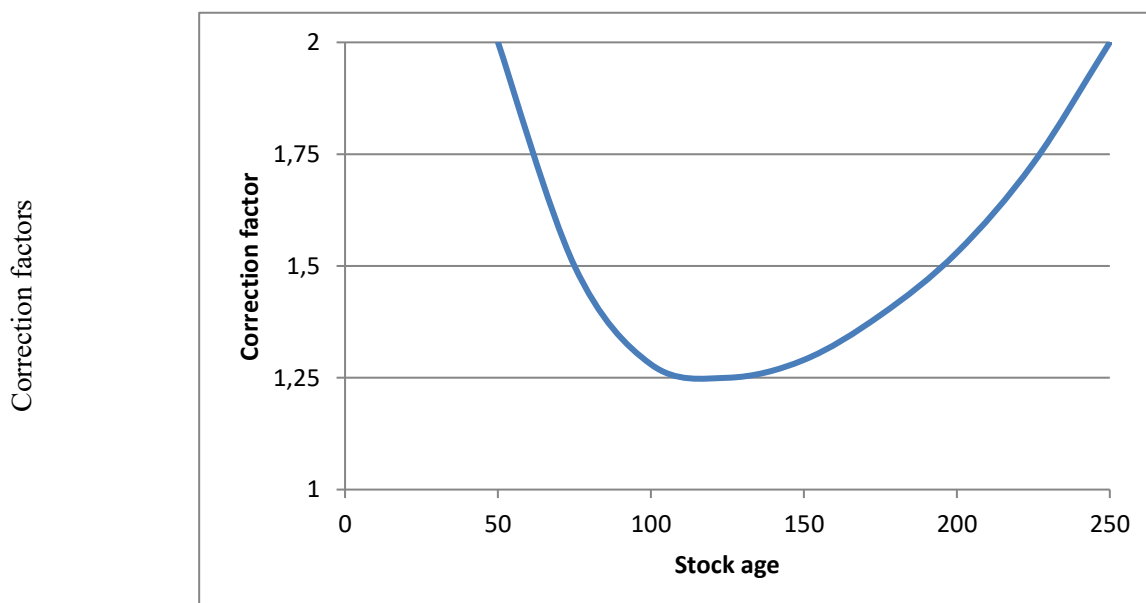



**Fig. 2.?** *Principled picture of correction factor's dependence on stand age*

### Heterogeneous tree covered impediment

Soils characterized by the fact that the supply of water and nutrition varies across the area. Here and there, trees may grow and perhaps reach relatively high heights. Examples are rock-bound soils with cracks and depressions. The site productivity system usually does not work on such soils and gives too high a site productivity. The only support for calculating the site productivity, which can be obtained, is an approximate annual average growth determined as above.

## **2.9 SPLITTING**

The sample plot is divided if it is intersected by a boundary between land use classes. On productive forest land, a boundary is also made between different action units/stocks.

Furthermore, splitting takes place within an action unit (minimum part  $\geq 0.25$  ha) if the sample plot is divided by the boundary of *the site index* (at least 3 m difference), *the stand age* (at least 20 years difference), *closeness* (at least 2/10) or *tree species* composition (at least 3/10). On bare land, however, no division is made based on differences in age class, closeness and tree species composition. The specified rules refer to the average of the parts.

In addition, if *stump inventory* is to be carried out on productive forest land, it is divided for *cutting method* and the *felling boundary*. The same applies to inventory of volume reserve plots if the surface is divided by felling that has taken place within the last five years.

In *maturity classes A1 and B1* (bare land and young stand) division is also carried out based on felling age and regeneration measures carried out.

In addition, splitting within an action unit occurs if the sample area is

## 2.9 Technical instructions - Splitting

intersected by *a boundary of an anomalous part*. However, the area requirement  $\geq 0.02$  ha applies if the anomalous part is pre-growing and otherwise 0.1 ha.

For boundaries facing a power line, division is made only if the power line crosses productive forest land and within high mountains only in case of a boundary with fresh water.

For road and rail within or adjacent to fields, high mountains, developed land or other land, no division is made, but rather these are transferred to the respective neighbouring land use classes. Nor is the boundary between fields and developed land divided, but instead land use class is determined according to the land use class with the largest proportion of the sample plot area. However, where there are trees or stumps to be measured on the field part, splitting must take place.

The splitting refers to temporary plots with a radius of 7.0 m and permanent plots with a radius of 10.0 m.

A sub-sample plot must be at least of a size so that any point is more than 1.5 m from the periphery of the circle surface. However, the sub-sample plot may be as small as desired if the rest of the plot consists of a land use class that is not to be inventoried, while there are trees or stumps to be measured on the part in question.

The dividing boundary is specified as a sequence of split points, referred to as trains, which are defined by compass direction (degrees) and distance from the centre, referred to as polar coordinates. The points are marked on the ground with wooden sticks, which are removed on leaving the plot. A so-called train is specified for each sub-sample plot, except one that becomes a residual part. When splitting a stump plot where a part is not to be inventoried, the non-inventoried part is the residue part. The split is thus described for the sub-sample plot(s) to be inventoried.

The following applies to the description of the sub-sample plots:

- Each sub-sample plot must be limited to some extent by the periphery of the circular sample plot.
- The first and last points must be located on the periphery of the circular sample plot surface.

## 2.9 Technical instructions - Splitting

- The dividing points must be described clockwise.
- The first line of the train must not be a circular arc.
- If two dividing points, between the first and last breakpoints, are on the periphery, the line between them must be a circular arc. Otherwise, other sub-sample plots must be described, and this one then becomes a residual part (see example below).
- The number of dividing points may not exceed 8.
- The sample plot may be divided into a maximum of 5 parts.

The sub-sample plots can be described in any order and receive numbers according to the order in which they are described. Previously, the sub-sample plots have been numbered in the order in which they were found in the regular walking direction. In order to reduce the risk of errors, it is recommended to continue as a rule by describing the sub-sample plot that is found first in the regular walking direction. This will then receive the number 1.

When re-inventorying permanent surfaces, the split decision from the previous inventory is amended only in case of a real change necessitating such amendment. In addition, a split may be changed if the previous split is manifestly incorrect and the split is due to a boundary between different land use classes. Thus, an incorrect split between sub-sample plots on productive forest land is not amended. If a sample plot has been split previously, but the split is now unwarranted, the split is cancelled. However, the split should be kept if the dividing boundary is also a property boundary, as different management of the sub-sample plots can be expected in the future.

Incorrectly made splits and incorrectly numbered sub-sample plots create unnecessary concerns in the continued management of the data material. It is therefore of the utmost importance that a registered split is carefully checked before starting work on the sample plot. The data collector gives a drawn-up image of the registered split. This image must always be

checked.

If, on a permanent plot, the numbering of the sub-sample plots is already incorrect, as may occur, no correction should be made, but the sub-sample plots must retain their original designations.

Example :

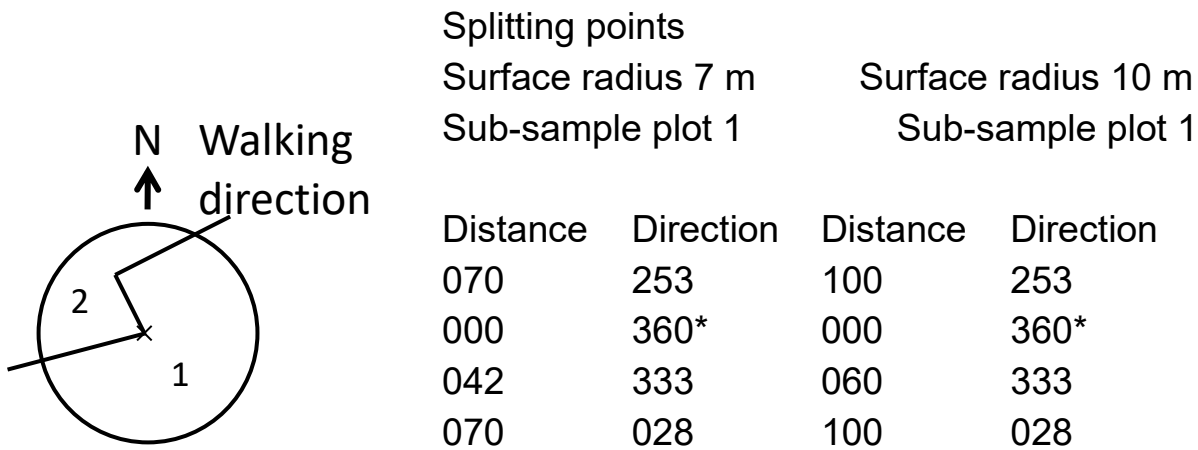

\* The direction of the breakpoint in the sample plot centre is set to "360".

Fig. 2.4 a ^

Multiple parts can belong to the same action unit or part of an action unit and have an identical description. For example, if a small road or power line cuts through the stand, these parts are combined into a sub-sample plots and described as residual. Trains should not be indicated.

## **2.11 CONTROL OF DATA**

### **Directly at registration in Allegro3**

Rules for what should/can be registered and which registration intervals are allowed are largely included in the field computer.

The program also detects when you enter a value for a variable that is outside a normal registration range. When an attempt is made to register an "abnormal" value that is outside the normal range, the user is warned with a yellow warning triangle to the left of the proposed value.

An "abnormal value" can be a high or low value in absolute terms, or in relation to something else that has been registered, or on P-plots it may be in relation to what was recorded last time.

A yellow warning triangle does not mean that the registered value is incorrect, but that the value registered is unexpected and should therefore be checked. If the warning concerns a measured value, the measurement must be repeated. Registrations that, after checking, turn out to be correct, should of course be kept despite the warning triangle!

### **Sample plot test**

When the work on the sample plot is completed and the computers data is synchronized, all recorded data is tested for logical consistency. The tests are carried out in the team leader computer and the results are presented in a list. The list also includes the warnings received in connection with the registrations, see above.

## **3 REGISTRATION OF IDENTIFICATIONS**

### **3.2 IDENTIFICATION OF TRACT**

#### **TRACT**

The current tract is selected from a list of tracts in the field computer. The tract code consists of a four-digit code.

#### **DATE**

Dates are retrieved automatically by the Forest & Soil program from the field computers's watch.

#### **TEAM NUMBER**

Team number is stated when user profile is registered in the field computer.

### **3.3 IDENTIFICATION OF SAMPLE PLOT CENTREPOINT**

#### **PAGE**

| Code | Tract side   |
|------|--------------|
| 1    | <i>North</i> |
| 2    | <i>East</i>  |
| 3    | <i>South</i> |
| 4    | <i>West</i>  |

#### **SAMPLE PLOT**

sample plot centrepoint, m

Code, for example: *400*

### 3.3.1 Registration of identifications - Registration of change of land use class.

Tract side and sample plot centrepoin are selected in the sample plot centrepoin selector.

#### **STUMP INVENTORY**

Code Type of inventory (intermediate stump plots only)

0 *No stump inventory*

1 *Stump inventory*

#### **LAST PLOT CENTRE?**

Code Has the sample plot centre been found?  
(permanent sample plot only)

0 *Not found*

1 *Found*

Regarding new arrangement of sample plots, section 2.6.

#### **OBSERVED IN THE FIELD?**

Code Has the sample plot been observed in the field?

0 *No*

1 **Yes**

#### **CHANGE SPLIT?**

Code Change of previous split (permanent sample plot only)?

0 *No*

1 **Yes**

### **SUB-SAMPLE PLOTS**

| Code | Number of sub-sample plots |
|------|----------------------------|
| 1    | <i>One</i>                 |
| 2    | <i>Two</i>                 |
| 3    | <i>Three</i>               |
| 4    | <i>Four</i>                |
| 5    | <i>Five</i>                |

### **3.3.1 REGISTRATION OF LAND USE CLASS CHANGE**

For permanent sample plots where the land use class has changed since the previous inventory, an estimation must be made of the timing of the change. If forest has been felled in connection with the change, the time of the felling must be assessed and be registered regardless of when the actual change of land use class took place.

### **TIMING**

| Code | Timing of change of land use class |
|------|------------------------------------|
| 00   | <i>Current season</i>              |
| 01   | <i>Season 1</i>                    |
| 02   | <i>Season 2</i>                    |
| 03   | <i>Season 3</i>                    |
| 04   | <i>Season 4</i>                    |
| 05   | <i>Season 5</i>                    |
| 10   | <i>Season 6+</i>                   |



## 3.4 SUB-SAMPLE PLOT VARIABLES AND SPLIT

### SUB-SAMPLE PLOT

Code Sub-sample plot number for the described sub-sample plot

0 *Sample plot is not split*

1-5 *Area number for split sample plot*

### 3.4.1 REGISTRATION OF SPLIT

#### DISTANCE

Distance to splitting point (dm)

Codes: 0-100 (P-plot)

0-70 (T-plot)

#### DIRECTION

Direction to splitting point (degrees)

Codes: 1-360

The direction to the splitting point in the plot centre is set to 360°.

## 3.4.2 REGISTRATION OF SUB-PLOT VARIABLES

### STUMP INVENTORY

| Code | Type of inventory (stump plots only) |
|------|--------------------------------------|
| 0    | <i>No stub inventory</i>             |
| 1    | <i>Stub inventory</i>                |

### COUNTY

| Code | County |
|------|--------|
|------|--------|

---

|    |   |
|----|---|
| 1  | <i>Norrbottn County, lappmark</i>   |
| 2  | <i>Norrbottn County, coastal land</i>   |
| 3  | <i>Västerbottn County, lappmark</i>   |
| 4  | <i>Västerbottn County, coastal land</i>   |
| 5  | <i>Jämtland County, Jämtland and the Härjedal part of Bergs municipality</i>      |
| 6  | <i>Jämtland County, Härjedalen except the Härjedal part of Bergs municipality</i> |
| 7  | <i>Västernorrland County, Ångermanland part</i>                                   |
| 8  | <i>Västernorrland County, Medelpad</i>  |
| 9  | <i>Gävleborg County, Hälsingland</i>  |
| 10 | <i>Gävleborg County, Gästrikland</i>  |
| 11 | <i>Dalarna County, Särna and Idre parishes (part of Älvdalen municipality)</i>    |
| 12 | <i>Dalarna County, except Särna and Idre parishes</i>                             |
| 13 | <i>Värmland County</i>  |
| 14 | <i>Örebro County</i>  |
| 15 | <i>Västmanland County</i>   |
| 16 | <i>Uppsala County</i>   |
| 17 | <i>Stockholm County</i>   |
| 18 | <i>Södermanland County</i>  |
| 19 | <i>Östergötland County</i>  |
| 20 | <i>Västra Götaland County, formerly Skaraborg County</i>                          |
| 21 | <i>Västra Götaland County, Dalsland part of the former</i>                        |

### 3.4.2 Registration of identifications - Registration of sub-sample plot variables

- Älvsborg County*
- 22 *Västra Götaland County, Dalsland part of the former Älvsborg County*
- 23 *Jönköping County*
- 24 *Kronoberg County*
- 25 *Kalmar County*
- 26 *Västra Götaland County, Gothenburg and Bohus County*
- 27 *Halland County*
- 28 *Skåne County, former Kristianstad County*
- 29 *Skåne County, former Malmöhus County*
- 30 *Blekinge county*
- 31 *Gotland County*

### LAND USE CLASS

| Code | land use class                         | Code | land use class                                  |
|------|--|------|---|
| 1    | <i>Productive forest land</i>          | 9    | <i>Road and rail</i>                            |
| 2    | <i>Natural pasture</i>                 | 10   | <i>Power line within productive forest land</i> |
| 3    | <i>Arable land</i>                     | 13   | <i>Developed land</i>                           |
| 4    | <i>Morass</i>                          | 14   | <i>Other land</i>                               |
| 5    | <i>Rock and some other impediments</i> | 15   | <i>Freshwater</i>                               |
| 6    | <i>Subalpine coniferous woodland</i>   | 16   | <i>Saltwater</i>                                |
| 7    | <i>High mountains</i>                  |      |   |

The land use class classification is based on the condition of the soil at the time of the inventory, without regard to the possibilities for production-improving measures. Nor should expected changes in land use be taken into account as long as these have not occurred.

Below is a description of the different types of land use classes:

#### **1** *Productive forest land*

Land that is suitable for timber production and that is not used to any significant extent for other purposes. The land is considered suitable if it can produce an average of at least 1 m<sup>3</sup>fo per ha and year at 100 years

growing season (minimum site productivity VIII according to Jonson or H100 higher than about 10 m). Productive forest land includes grazed land with a tree layer with a closeness of  $> 0.3$  and an area  $> 0.25$  ha. Productive forest land also includes abandoned agricultural land and other unused land suitable for forest production, unless forestry is a clearly unsuitable land use (e.g. in areas with ancient monuments). Agricultural land that has not been used for the past three years is considered abandoned and transferred to productive forest land. However, as long as the land is claimed through mowing, regardless of whether the grass is used or not, the land is classified as *arable*. Nurseries and seed orchards are classified as *developed* land. Ornamental green plantations and clear cases of Christmas tree plantations on former arable land are classified as arable land as well as energy forest plantations. However, no stock count takes place in these cases.

When transferring productive forest land to other types of land use, e.g. *roads*, *quarries* and *developed land*, no change of land use class is deemed to have been made until the humus layer has been removed.

Productive forest land also includes isolated narrow strips of tree-bearing land that meet the area requirement (at least 2,500 m<sup>2</sup>) and that are surrounded by other land use classes. In the case of watercourses wider than 2 m, the above requirements must be met on each side separately. If the width is less than 5 m, the "forest strip" is moved to adjacent land use classes except water.

## **2** *Natural pasture*

Land that is mainly used for grazing and that is not ploughed regularly. The land use class is often characterized by tufts, stones, some shrub vegetation or high soil moisture. In addition, such land is usually in a worse position in relation to buildings than arable land. When converting to *productive forest land*, such land must be able to produce an average of at least 1 m<sup>3</sup>fo per ha and year. Grazing on impediments is transferred to the respective land use class.

## **3** *Arable land*

Land used for plant cultivation or grazing and which is regularly ploughed or maintained through mowing. Arable land also includes adjacent land

areas where clearing for arable land takes place regularly. In addition, the following types of soil are transferred to arable land, but no stock count takes place in these cases. Land used for professional cultivation of kitchen plants, fruit, berries, lawns, ornamental greenery, energy forest and clear cases of Christmas tree cultivation on former arable land. Tree groves <0.25 ha within arable land are transferred to arable land.

#### 4 Morass

The site productivity according to Jonson is less than 1 m<sup>3</sup>fo per ha and year. Wet soil with usually peat-forming plant communities. However, the soil does not have to be peat soil in the sense that the peat depth exceeds 30 cm. Usually treeless or sparsely wooded. *Morass* includes bogs and marshes. In the borderland with the mountain range, the classification of areas with “*wet land with usually peat-forming plant communities*” is governed by the adjacent land use classes, *productive forest land*, *Subalpine coniferous woodland* and *high mountains*. If *productive forest land* or *Subalpine coniferous woodland* is closest, it is a *morass*. Otherwise it is *high mountains*. See figure below!

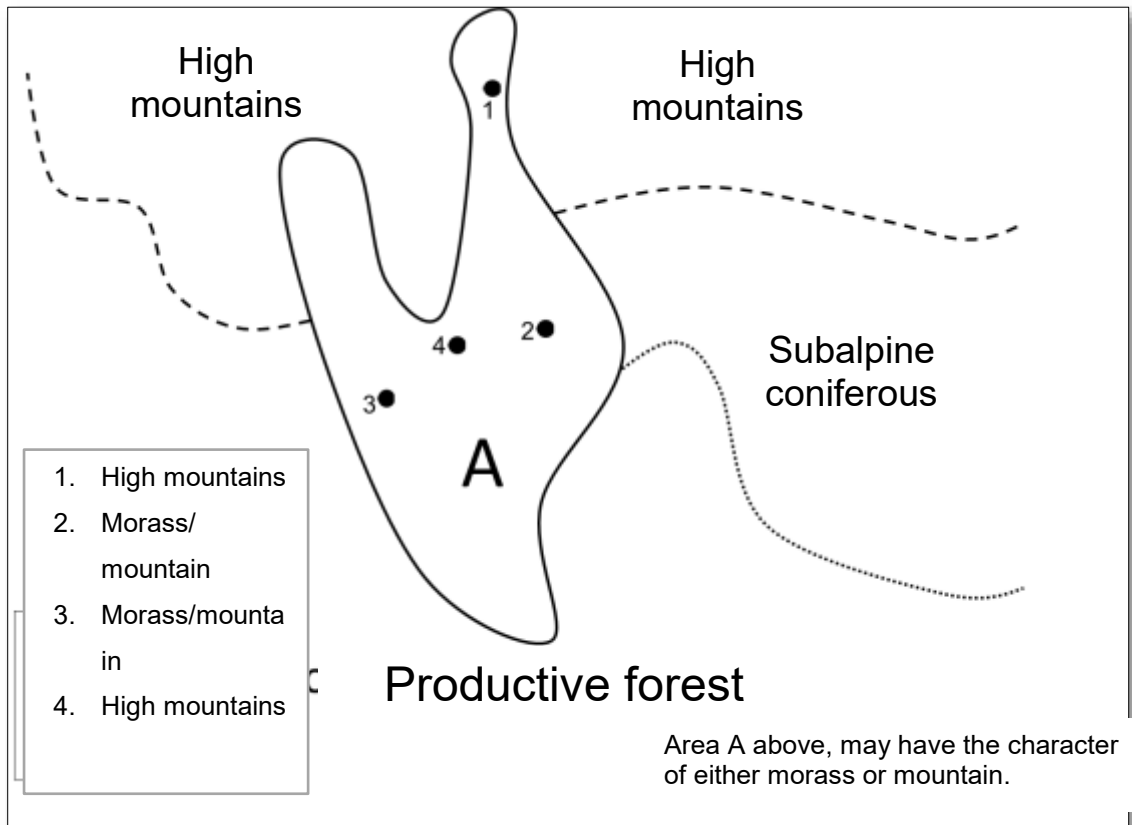

**Fig. 3.1** Classification of morass in borderland towards the mountain range.

## 5 *Rock and some other impediments*

The site productivity according to Jonson is less than 1 m<sup>3</sup>fo per ha and year. Exposed bedrock, rocky ground, pebble fields, sandy beaches (bare sand beaches or pebble beaches), Öland's alvar, etc. similar soil types. In the borderland with a mountain range, the classification of areas with "*mountainous terrain*" is governed by the adjacent land use classes, *productive forest land*, *Subalpine coniferous woodland* and *high mountains*. If *productive forest land* or *Subalpine coniferous woodland* is closest, it is *rock*. Otherwise it is *high mountains*. See figure previous page!

## 6 *Subalpine coniferous woodland*

Elevated land where the site productivity according to Jonson is lower than 1 m<sup>3</sup>fo per ha and year. The reason for this is neither excess water nor shallow soil depth. Usually occurs as a transition zone between productive forest land and high mountains. Conifers are seldom able to form closed stands, but are usually grouped. Individuals of conifers should have a height of at least 3 m. The birch is normally crooked. In order for *Subalpine coniferous woodland* to be distinguished, there must be at least 5 conifers/conifer clones within an area of 0.25 ha. The trees must have a maximum distance of 50 m from each other.

→ *Note that the Subalpine coniferous woodland must contain conifers or at least stumps of conifers.*

If the forest close to the mountains is pure birch forest without a significant element of conifers (or stumps of such), it is classified as *high mountains* if the site productivity is less than 1 m<sup>3</sup>fo per hectare and year. In *Subalpine coniferous woodland*, there is no division (on permanent plots new split) between *Subalpine coniferous woodland* and other forest-bearing impediments that meet specified requirements for afforestation.

## 7 *High mountains*

Bare or sparsely wooded areas above the coniferous border. In *high mountains*, only *productive forest land*, *Subalpine coniferous woodland* and *freshwater* are reported as other land use classes. The boundary between *Subalpine coniferous woodland* and *high mountains* is characterized e.g. by the following:

### 3.4.2 Registration of identifications - Registration of sub-sample plot variables

If there is only birch on the slopes toward the bare mountain, the site productivity limit of 1 m<sup>3</sup>fo per ha and year is decisive. As soon as the Jonson site productivity is less than this value, the land use class is *high mountain*. This means that the "lower" limit of the land use class *high mountain* is lower when only birch grows on the slopes towards the high mountain than when *Subalpine coniferous woodland* occurs. If there are conifers on the slopes towards the bare mountain, a Subalpine coniferous woodland zone is distinguished as above. Only occasionally, semi-creeping, shrub-like individuals of pine and spruce may normally be found on the land use class *high mountain*. However, solitaires of taller conifers may occur. Furthermore, in the transition zone between *Subalpine coniferous woodland* and *high mountain*, the two land use classes may alternate. When determining the land use class, the general area requirement of 0.25 ha is applied. Stumps that indicate a previously more abundant occurrence of conifers must not occur.

## 9 Road and rail

*Road* means roads for permanent use with a width of at least 5 m. Road includes road plot, banquetts, ditches, parking lots, etc. and land where the forest is regularly cleared for visibility. Note that even exercise tracks with a width of at least 5 m are included in the category road. The width of the road is therefore crucial.

*Railway* means an area for rail traffic. Railway includes a larger area than the track bed, namely the entire area where forestry cannot be conducted due to the railway's existence. Such an area is often fenced, which facilitates the demarcation.

For road and rail within or adjacent to *arable land*, *high mountains*, *developed land* or *other land*, is transferred to the respective neighbouring land use classes.

## 10 Power line in productive forest land

Streets for electrical wiring with a width of at least 5 m located on land that would otherwise be *productive forest land*. If the width does not exceed 5 m, the street is included in *productive forest land*. The boundary between the power line and the productive forest land is defined by an imaginary

straight line that touches the tree trunks (or if the stand has been felled, the stumps) on the forest land.

### **13** *Developed land*

Developed land includes urban areas, parks adjacent to buildings (the field vegetation layer must be maintained), industrial area, land adjacent to military facilities (usually fenced), shooting ranges, golf courses, sports facilities including slalom facilities (actual descent) but excluding electric light trails with a width of at least 5 m (road), facilities for outdoor swimming pool, airfields, plots, gardens, seed orchards and nurseries.

→ *Please note that other "Land use classes" are also added to developed land, but not forest areas (unless they meet the criteria for a park) and water, if they are within the above-mentioned types of land. The specified minimum areas for distinguishing between different land use classes (section 2.7) may be exceeded.*

Areas adjacent to developed areas where measures have been taken to prevent the emergence of tree vegetation are also included in developed land. Unclaimed plots of land can be classified as developed land up to 15 m from houses.

### **14** *Other land*

All land that is not attributed to the land use classes described above. This includes, for example, storage sites, rest areas, gravel pits, peat mines and mines in use.

### **15** *Freshwater*

Lakes and watercourses of all kinds, including dug canals, at least 2 m wide and dams. Watercourses narrower than 2 m are transferred to adjacent land use classes.

Areas that - found on-site - are below the maximum dam limit are also included in freshwater.

### **16** *Saltwater*



### 3.4.2 Registration of identifications - Registration of sub-sample plot variables

All seawater is included in saltwater.

→ *Please note, however, that lakes and watercourses on islands in the sea are included in the freshwater area. The boundary against saltwater is determined by the normal water level.*

#### **PASTURE?**

7/10 m-plot

Code    Is the sample area located on pasture?

0        *No*

1        **Yes**

*Pasture* is registered only when the land use class is *natural grazing*. Pasture is characterized by the ground being difficult or impossible to plough due to rocks, slabs, shrubs, trees and/or high groundwater. Beach meadows and similar land that is used for grazing are classified as pasture. Most of the natural grazing consist of pasture. Those that are not pasture are, with few exceptions, old arable land that is not regularly ploughed but which could be ploughed without obstacles. Land that has previously been ploughed is not normally classified as pasture. One can think of a few of cases where the classification of the value of the variable pasture changes over time.

- A. Previously ploughed land where a sparse tree layer or groups of trees have been established and the trees have grown to an average diameter of more than 10 cm.
- B. Previously ploughed land where the ground water level has been raised so that ploughing is basically impossible.

### **3.5 REGISTRATION OF GPS DATA**

All inventoried sample plots, both volume reserve and stump plots, must be given coordinates. Registration is done in the GPS menu.

**GPSNORD**

**GPSOST**

### 3.5 Registration of identifications - Registration of GPS data.

Coordinates according to old data shown on the field computer's display,  
SWEREF (m).

Codes, e.g.:

|                |                |
|----------------|----------------|
| <i>GPSNORD</i> | <i>7105500</i> |
| <i>GPSOST</i>  | <i>1673500</i> |

#### **CENTRE?**

Code Is the GPS receiver located in the plot centre?

|   |            |
|---|------------|
| 0 | <i>No</i>  |
| 1 | <b>Yes</b> |

If the GPS receiver is placed within 1 m of the centre of the sample plot, Yes, otherwise No.

#### **AVSTGPS**

Distance from plot centre to GPS receiver (m).

Codes: *1-99*

If the receiver is not placed in the centre of the sample plot, the distance from the centre of the plot to the receiver is indicated to the nearest meter.

#### **RIKTGPS**

Direction from the plot centre to the GPS receiver (degrees).

Codes: *1-360*

If the receiver is not placed in the plot centre, the direction from the plot centre to the receiver is specified to the nearest degree.

#### **AVVNORD**

#### **AVVOST**

### 3.5 Registration of identifications - Registration of GPS data.

Deviation between coordinates according to old data and the coordinates (m) of the GPS receiver.

Codes, e.g.:

*AWNORD 12*  
*AVVOST 4*

Estimated deviation in m between coordinates according to old data and GPS receiver's coordinates. An assessment is made as to whether the deviation between the coordinates of the sample plot according to old data and the corresponding GPS coordinates is reasonable. If not, check what is wrong.

**FAKNORD**  
**FAKOST**

If the GPS receiver is not located in the plot centre, the coordinates are recalculated in the field computer as the actual coordinates of the sample centre.

Codes, e.g.:

*FAKNORD 7105490*  
*FAKOST 1673461*



## 5 SITE DESCRIPTION

### 5.1 GENERAL

The inventory is divided across eight menus; **Site**, **Bored tree**, **Tree layer**, **Shrub layer**, **Game forage**, **Moose droppings**, **Small plant plot** and **Tree occurrence** ( **P** <sub>m</sub> tracts only on *high mountains*). Site inventory is carried out on reserve plots on the land use classes *productive forest land*, *natural grazing*, *morass*, *rock and certain other impediments*, *Subalpine coniferous woodland*, *high mountains and power lines within productive forest land*. Further, the menu Site is carried out on stub plots which are inventoried on the said land use classes. On the land use class *power line of productive forest land* , only the menus Shrub layer, Game forage, Moose droppings and Small plant plot are carried out. The menu Bored tree should be carried out on **P**-sample plots with land use classes *rocks*, *subalpine coniferous woodland*, *high mountains* and *productive forest land with felling class D*.

The menu Site is mainly inventoried on a circular plot with a 10 m radius. However, the Soil slope variable is determined on a plot of 20 m radius and the variable Bare sand is determined on the sample plot for caliper measurement of tree diameter in breast height (dbh) (7 alternatively 10 m radius). The Menus Bored tree and Tree layer, which also includes the registration of total basal area, are made on a plot of 20 m radius. The Shrub layer and Game forage menus are carried out on the sample plot for caliper measurement of tree diameter in breast height (dbh) (7 alternatively 10 m radius) and counting of Moose droppings is carried out on the small sample plot for caliper measurement of tree diameter in breast height (dbh) (radius 3.5 m). Inventory of *Vaccinium myrtillus* and *Vaccinium vitis-idaea* in the menu Small plant plot is carried out on two small plots with radius 0.28 m.

The steps of the site inventory and description units to which different steps relate are shown below:

| Description | See |
|-------------|-----|
|-------------|-----|

## 5.1 Ståndortsinventering – Allmänt

| <b>Step/variable</b>   | <b>unit</b>                 | <b>page</b>         |
|--|-----------------------------|---------------------|
| <b>5.2 Variables in Menu Site</b> .....  | -                           | 5:4                 |
| Soil Moisture Class ( <b>FUKTIGHET</b> ) .....                                   | 10 m surface                | 5:4                 |
| Movable groundwater ( <b>RÖRLMARV</b> ) .....                                    | 10 m surface                | 5:4                 |
| Peatland share ( <b>TORV</b> ) .....   | 10 m surface                | 5:6                 |
| Soil ( <b>JORDART</b> ) .....  | 10 m surface                | 5:6                 |
| Texture ( <b>TEXTUR</b> ) .....  | 10 m surface                | 5:7                 |
| Bare sand ( <b>BLOTTAD SAND</b> ).....   | 7/10 m-surface              | 5:8                 |
| Earth-depth ( <b>JORDDJUP</b> ) .....  | 10 m surface                | 5:8                 |
| Ditch within 25m? ( <b>DIKAT?</b> ) .....  | 10 m surface                | 5:9                 |
| Time of ditching ( <b>TIME</b> ) .....   | 10 m surface                | 5:9                 |
| Does the ditch work? ( <b>FUNGERANDE?</b> ) .....                                | 10 m surface                | 5:9                 |
| Bottom layer type ( <b>BOTTENSKIKT</b> ).....                                    | 10 m surface                | 5:10                |
| Field vegetation layer type ( <b>FÄLTSKIKT</b> ).....                            | 10 m surface                | 5:10                |
| Ground slope ( <b>LUTNING</b> ).....   | 20 m surface                | 5:11                |
| Slope direction ( <b>RIKTNING</b> ) .....  | 20 m surface                | 5:11                |
| Impact ( <b>PÅVERKAN</b> ) .....   | 10 m surface                | 5:12                |
| Tree species indicating site productivity ( <b>BONVIS</b> )                      | 10 m surface                | 5:13                |
| Site index H100 according to site factors ( <b>SIS</b> )                         | 10 m surface                | 5:13                |
| <b>5.3 Tree layer, shrub layer, game forage, moose droppings, and bored tree</b> | -                           | 5:16                |
| <b>5.3.1 Variables in Menu Tree Layer</b> .....                                  | -                           | 5:16                |
| Total Basal Area ( <b>TOT GRY</b> ).....   | 20 m surface                | 5:19                |
| Type of layer ( <b>SKTYPE</b> ) .....  | 20 m surface                | 5:19                |
| Average height of the layer ( <b>SKHÖJD</b> ).....                               | 20 m surface                | 5:21                |
| Number of trunks in the layer ( <b>SKSTA</b> ) .....                             | 20 m surface                | 5:22                |
| Layer's basal area ( <b>SKGRY</b> ) .....  | 20 m surface                | 5:22                |
| Number of over storey trees ( <b>ÖVSTANT</b> ) .....                             | 20 m surface                | 5:22                |
| Age of the layer ( <b>SKIKTÅLDER</b> ) .....                                     | 20-m surface                | 5:23                |
| Tree species layer ( <b>TRÄDSLAG, ANDEL</b> ) .....                              | 20 m surface                | 5:23                |
|  |                             | <i>cont</i> →       |
| <b>Step/variable</b>   | <b>Description<br/>unit</b> | <b>See<br/>page</b> |
| <b>5.3.2 Variables in Menu Shrub Layer</b>                                       | -                           | 5:25                |

## 5.1 Ståndortsinventering – Allmänt

|   |                |      |
|---|----------------|------|
| Shrub species ( <b>BUSKART</b> ) .....  | 7/10 m-surface | 5:25 |
| Cover of shrub species ( <b>TÄCKNING</b> ) .....  | 7/10 m-surface | 5:26 |
| <b>5.3.3 Variables in menu Game Forage</b> .....  | -              | 5:27 |
| Game forage species ( <b>VILTFODERART</b> ) .....   | 7/10 m-surface | 5:27 |
| Cover of game forage species ( <b>VILTTÄCK</b> ) .....  | 7/10 m-surface | 5:28 |
| Grazing pressure ( <b>BETE?</b> ) .....   | 7/10 m-surface | 5:28 |
| Grazed area ( <b>BETAD AREAL</b> ) .....  | 7/10 m-surface | 5:29 |
| Moose dropping mounds ( <b>SPILLNING</b> ) .....  | 3.5 m surface  | 5:29 |
| <b>5.3.4 Variables in Menu Bored Tree</b> .....   | -              | 5:30 |
| Remaining? ( <b>FINNS KVAR?</b> ) ...   | 20 m surface   | 5:30 |
| Diameter ( <b>DIAMETER</b> ) .....  | 20 m surface   | 5:30 |
| Tree species ( <b>TRÄDSLAG</b> ) .....  | 20 m surface   | 5:31 |
| Distance ( <b>AVSTÅND</b> ) .....   | 20 m surface   | 5:31 |
| Direction ( <b>RIKTNING</b> ) .....   | 20 m surface   | 5:31 |
| Breast height age ( <b>BRHÅLDER</b> ) .....   | 20 m surface   | 5:31 |
| <b>5.4 Variables in menu Small plant plot</b> .....   | -              | 5:32 |
| Species ( <b>ART</b> ) .....  | 0.28 m surface | 5:32 |
| Vegetation height ( <b>VEGHÖJD</b> ) .....  | 0.28 m surface | 5:33 |
| Stage of development of <i>Vaccinium vitis-idaea</i><br>and <i>Vaccinium myrtillus</i> ( <b>UTVECKLINGSSTAD</b> ).... | 0.28 m surface | 5:33 |
| Number of flowers/berries ( <b>ANTBLOM</b> ).....   | 0.28 m surface | 5:34 |

---

## 5.2 VARIABLES IN MENU SITE

### FUKTIGHET

10 m radius

Code Soil moisture class

- |   |                    |
|---|--------------------|
| 1 | <i>Dry</i>         |
| 2 | <i>Fresh</i>       |
| 3 | <i>Fresh-moist</i> |
| 4 | <i>Moist</i>       |
| 5 | <i>Wet</i>         |

### RÖRL MARV

10 m radius

Code Movable groundwater

- |   |                      |
|---|----------------------|
| 1 | <i>Rarely-absent</i> |
| 2 | <i>Brief periods</i> |
| 3 | <i>Long periods</i>  |

Classification is made according to sketch on the next page:

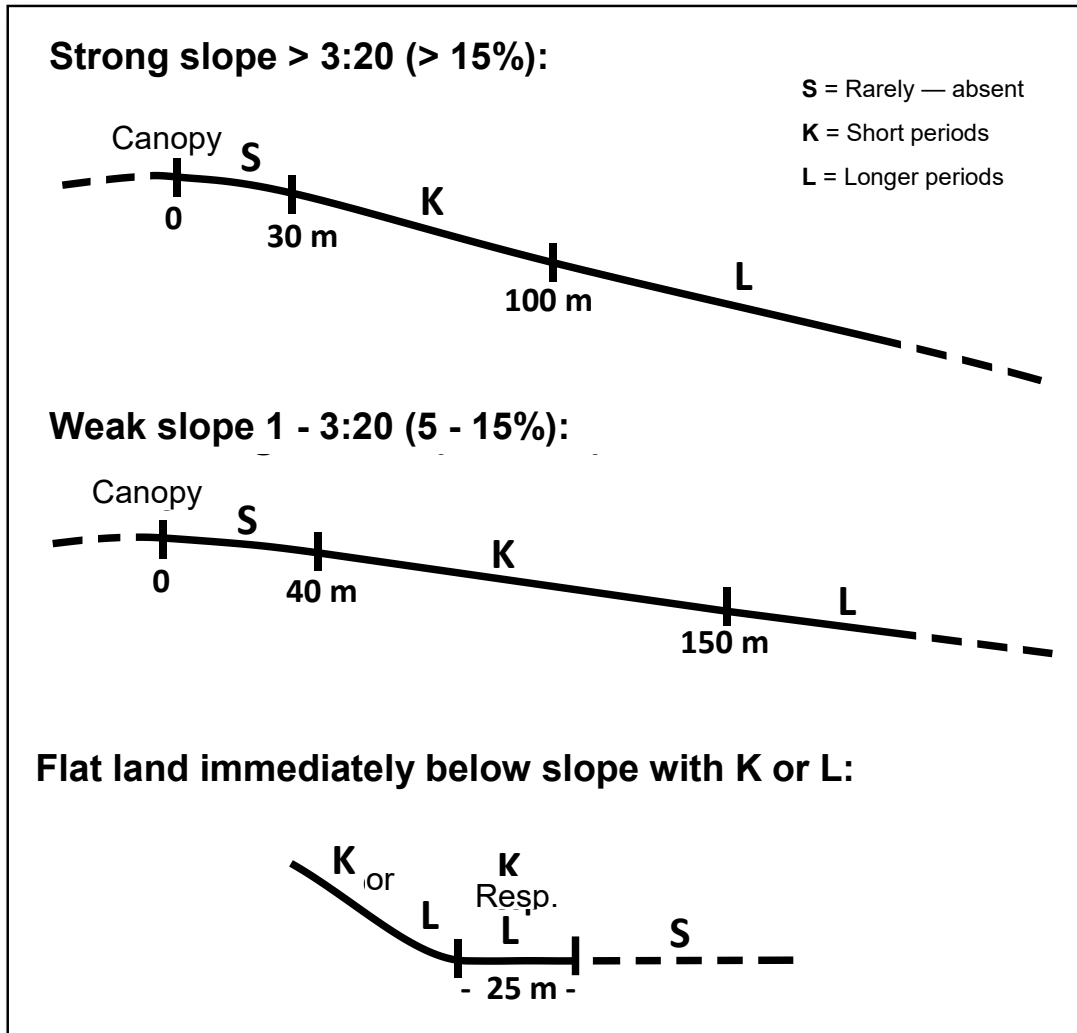

Fig. 5.1 Rating of movable groundwater.

→ Distances are calculated from the canopy to sample plot centre.

If the sample plot is supplied with water from different main directions, the distances to the canopies are added up and the assessment is based on the average incline of the slope.

When assessing the presence of movable groundwater, it is necessary to take into account such areas above the sample plot that efficiently divert the water that would otherwise reach the surface, such as ditches adjacent to forest car roads or major roads. In such cases, when determining the movable groundwater class, only the section in the main direction of the slope from the sample plot up to the site of the procedure (fictitious canopy) is taken into account.



## PEAT

10 m radius

The variable indicates the proportion of the sample plot which is peatland. Registered in the following classes:

| Code | Peatland proportion   |
|------|---|
| 0    | <i>Only solid soil, peatland not found on the</i>                       |
| 1    | <i>Peatland covers less than half the plot</i>                          |
| 2    | <i>Peatland covers more than half the plot, but not the entire plot</i> |
| 3    | <i>Only peatland</i>  |

The soil is classified as solid soil if somewhere within the sample/subplot there is mineral soil within 30 cm depth of the soil surface. However, even when the surface is classified as *peatland*, blocks, rock or minor interference of mineral grains may occur in the peat. When assessing the proportion of peat layer on the sample plot, isolated peatland patches smaller than 25 m<sup>2</sup> are disregarded. At peat depths near 30 cm and at varying conditions, numerous probes must be made to determine the peatland proportion.

## SOIL SPECIES

10 m radius

For the determination of the variables Soil species and Texture (see next variable), adjacent to the sample plot centre, or in the middle of a split plot, a soil sample is taken with a probe. The sample must be obtained from layers of soil which are deeper than Fuller's earth, i.e. normally from the coarse silt layer. If there is no Fuller's earth, the sample should be taken from at least a 20 cm depth, calculated from the lower boundary of the humus layer. If *blocks* and *rock* are present in such quantity at sample plot centres that mineral soil cannot be obtained, tests are made with the probe in a helical pattern from the centre and outward until a sample can be

taken. If, despite this, mineral soil is not found, the soil is classified as *moraine* or *cop*. The texture is specified as *rocky moraine* (code “1”). However, if the soil species *cop*, Texture is not indicated, nor are the variables Soil Depth and Bare Sand.

Soil species is recorded according to the following classes:

| Code | Soil species                           |
|------|--|
| 1    | <i>Sediment with High Sorting Rate</i> |
| 2    | <i>Sediment with Low Sorting Rate</i>  |
| 3    | <i>Moraine</i>                         |
| 4    | <i>Rock</i>                            |

#### 4 *Rock*

is not, in reality, a type of soil, but on *copland* where the mineral soil layer is 10 cm at its thickest, the soil is classified as *rock*.

## TEXTURE

10 m radius

*The texture of the soil is determined on the same soil sample as Soil species above, and recorded according to the following classes:*

| Code | <u>Sediment</u> ●  | <u>Moraine</u> ■     |
|------|--------------------|----------------------|
| 1    | <i>Rock/block</i>  | <i>Rocky/blocky</i>  |
| 2    | <i>Gravel</i>      | <i>Gravelly</i>      |
| 3    | <i>Course sand</i> | <i>Sandy</i>         |
| 4    | <i>Medium sand</i> | <i>Silty</i>         |
| 5    | <i>Course silt</i> | <i>Sandy-silty</i>   |
| 6    | <i>Coarse silt</i> | <i>Silty</i>         |
| 7    | <i>Fine silt</i>   | <i>Fine silt</i>     |
| 8    | <b><i>Clay</i></b> | <b><i>Clayey</i></b> |

## BARE SAND

7/10 m-radius

The area (m<sup>2</sup>) of *bare sand* is assessed for the 7/10 m <sub>radius</sub>. Bare sand means an aggregate area of at least 1 dm<sup>2</sup> large patches where organic matter is basically absent and the mineral soil is on the surface.

Bare sand

|        |                       |       |
|--------|-----------------------|-------|
| Codes: | <i>Permanent plot</i> | 0-314 |
|        | <i>Temporary plot</i> | 0-154 |

→ *Bare sand is recorded only on volume reserve plots where the soil species is sediment (code '1' or '2') and the texture code '3', '4' or '5'.*

## SOIL-DEPTH

10 m radius

*Average soil depth* is recorded according to the following classes:

| Code | Soil-depth            |
|------|-----------------------|
| 1    | <i>Ample</i>          |
| 2    | <i>Fairly shallow</i> |
| 3    | <i>Shallow</i>        |
| 4    | <i>Highly varied</i>  |

**1** *Ample soil depth.* More than 70 cm. No visible cops

**2** *Fairly shallow soil depth.* Between 20 and 70 cm. Occasional cops. Sites on flat or slightly sloping ground with abundant occurrence of a hardpan.

**3** *Shallow soil depth.* Less than 20 cm. Plentiful of cops.

**4** *Very varying soil depths.* Fractures in the bedrock partly visible.

→ *If the soil species is rock (code "4"), soil depth is not specified.*

### DIKAT?

Within 25 m

Code Ditch within 25m of the plot centre?

0 No

1 Yes

The 10 m area is considered to be ditched if there are interventions within 25 m of the centre that drain or have drained the land. This includes:

- trenches
- cleared or widened natural streams, such as creek furrows
- road ditches
- stepped slopes to major roads

→ *Please note that ditches or drainage interventions outside any land use class boundary should also be taken into account.*

### TIMING

Code Time of ditching

1 *Current stand*

2 *Previous stand*

When ditching on bare land and non-productive woodland, “former *stand*” is indicated.

### FUNGERANDE?

Code Does the ditch function?

0 No

1 Yes

## BOTTENSKIKT

10 m radius

*Bottom layer type* is recorded in the following classes:

| Code | Bottom layer type              | Code | Bottom layer type                                |
|------|--------------------------------|------|--|
| 1    | <i>Type of lichen</i>          | 4    | <i>Type of sphagnum</i>                          |
| 2    | <i>Sphagnum rich in lichen</i> | 5    | <i>Wetland moss type<br/>(not Sphagnum type)</i> |
| 3    | <i>Type rich in lichen</i>     | 6    | <i>Bryophyte type</i>                            |

### Wetland mosses:

- ◆ *Polytrichum commune*), *P. gracile*) and *P. strictum*,
- ◆ *Sphagnum*-species, as well as
- ◆ Bryophytes; often brown, brownish-yellow or brown-green species mainly belonging to the genera *Drepanocladus*, *Scorpidium*, *Paludella*, *Calliergon*, *Tomentypnum* and *Campylium*.

### Lichen:

- ◆ all types of land lichen, including crustose lichen.

## FÄLTSKIKT

10 m radius

*Field vegetation layer type* is recorded in the following classes:

| Code | Field vegetation layer type                        | Code | Field vegetation layer type         |
|------|--|------|-------------------------------------|
| 1    | <i>Tall herbs without stems</i>                    | 9    | <i>Narrow grasses</i>               |
| 2    | <i>Tall herbs with stems/Vaccinium myrtillus</i>   | 10   | <i>Tall Carex</i>                   |
| 3    | <i>Tall herbs with stems/Vaccinium vitis-idaea</i> | 11   | <i>Low Carex</i>                    |
| 4    | <i>Low herbs without stems</i>                     | 12   | <i>Equisetum</i>                    |
| 5    | <i>Low herbs with stems/Vaccinium myrtillus</i>    | 13   | <i>Vaccinium myrtillus</i>          |
| 6    | <i>Low herbs with stems/Vaccinium vitis-idaea</i>  | 14   | <i>Vaccinium vitis-idaea</i>        |
| 7    | <i>Without field vegetation layer</i>              | 15   | <i>Empetrum nigrum/Heather</i>      |
| 8    | <i>Broad Grasses</i>                               | 16   | <i>Poor field vegetation bushes</i> |

Field-layer type registration takes place on solid soil as well as peatland regardless of the bottom layer.

## **SLOPE**

20 m radius

*Ground slope* (gradient) is recorded in the following classes:

| Code | Ground slope              | Code | Ground slope              |
|------|---------------------------|------|---------------------------|
| 01   | <b>0</b> - 1 0:20         | 07   | <b>4</b> : 1:20 - 7.0:20  |
| 02   | <b>1</b> . 1:20 - 2. 0:20 | 10   | <b>7</b> : 1:20 - 10.0:20 |
| 04   | <b>2</b> :1:20- 4.0:20    | 11   | <b>10</b> . 1:20 -        |

The ground slope is measured by altimeter and is read on the 20 m scale. Slope refers to the strongest slope that can be found between two diametrically opposite points on the periphery of the 20 m radius. Small pits, boulders or similar are disregarded for this purpose. In the case of split plot, the assessment is made on the part of the 20 m plot located within the same action unit/part of the action unit as the sub-sample plot.

## **DIRECTION**

20 m radius

Slope direction (degrees)

Codes: 1-360

The *direction* of the slope, i.e. the direction it faces, is indicated for slopes exceeding 1:20.

## **IMPACT**

10 m radius

*Impact* refers to a description of whether any part of the 10 m plot is impacted by water in addition to the variables Soil moisture and Movable groundwater. The variable is not recorded on the land use class *rock* nor on stump plots.

Registration is done in the following classes:

| Code | Impact                      |
|------|-----------------------------|
| 0    | <i>No impact</i>            |
| 2    | <i>Overscolding</i>         |
| 3    | <i>Source impact</i>        |
| 4    | <i>Occasionally flooded</i> |

**0** *No impact*

**2** *Overscolding*

Overscolding refers to areas along wet areas which for much of the year are affected by non-stagnant superficial lying water.

**3** *Spring impact*

Spring-impacted land refers to areas around springs.

**4** *Occasionally flooded*

Occasionally flooded area includes low-lying areas around marshes, lakes and running water that bear traces of flooding.

If several types of impact occur, the one with the lowest code is specified.

## BONVIS

10 m radius

*Tree species* indicating site productivity are indicated for pine or spruce.

| Code | Tree species  |
|------|---------------|
| 1    | <i>Pine</i>   |
| 2    | <i>Spruce</i> |

Tree species indicating site productivity means the tree type to which the site index should refer. Within the National Forest Inventory, only *pine* or *spruce* are used for this purpose.

## SIS

10 m radius

*Site area index* - H100, m - according to site factors.

The value, *two digits*, is calculated and indicated by the field computer.

The site index H100 with respect to the tree species indicating site productivity is calculated using registered site characteristics.

**Tab. 5.1** Table for determining site productivity, m<sup>3</sup>fo/ha and year.

| TREE-SPECIES | AREA, ETC. *  | SITE INDEX                                      |     |     |     |     |     |     |     |     |     |     |    |    |    |
|--------------|---|---|-----|-----|-----|-----|-----|-----|-----|-----|-----|-----|----|----|----|
|              |   | 10  | 12  | 14  | 16  | 18  | 20  | 22  | 24  | 26  | 28  | 30  | 32 | 34 | 36 |
|              |   | SITE PRODUCTIVITY M <sup>3</sup> FO/HA AND YEAR |     |     |     |     |     |     |     |     |     |     |    |    |    |
| PINE         | D-counties 1-8+11<br>More than 200 MSL                                      | 1.1   | 1.6 | 1.9 | 2.5 | 3.1 | 3.7 | 4.4 | 5.2 | 6.0 | 7.1 | -   | -  | -  | -  |
|              | Rest of Sweden<br><i>Empetrum nigrum</i> -<br>heather type and<br>inferior. | 1.1   | 1.6 | 1.9 | 2.5 | 3.1 | 3.7 | 4.4 | 5.2 | 6.0 | 7.1 | -   | -  | -  | -  |
|              | Rest of Sweden<br><i>Vaccinium vitis-<br/>idaea</i> type and<br>better.     | 1.4   | 1.9 | 2.4 | 2.9 | 3.6 | 4.3 | 5.1 | 5.9 | 6.8 | 7.7 | 8.8 | -  | -  | -  |



5.2 Ståndortsinventering – Variabler i meny Ståndort  
5.2 Site inventory — Variables in Menu Site

|               |   |     |     |     |     |     |     |     |     |     |     |      |      |      |      |
|---------------|---|-----|-----|-----|-----|-----|-----|-----|-----|-----|-----|------|------|------|------|
| <b>SPRUCE</b> | <b>D-counties 1-8+11</b><br>Herb types, grass types and soil without field vegetation layers.   | 1.4 | 2.0 | 2.4 | 3.0 | 3.6 | 4.2 | 4.9 | 5.5 | 6.3 | 7.1 | -    | -    | -    | -    |
|               | <b>D-counties 1-8+11</b><br><i>Vaccinium myrtillus</i> -type and inferior.                      | 1.4 | 1.8 | 2.3 | 2.8 | 3.3 | 3.8 | 4.3 | 5.0 | -   | -   | -    | -    | -    | -    |
|               | <b>D-County 9,10,12,13</b><br>Herb types, grass types and soil without field vegetation layers. | -   | -   | -   | 3.6 | 4.3 | 5.0 | 5.8 | 6.6 | 7.5 | 8.4 | 9.3  | 10.4 | -    | -    |
|               | <b>D-County 9,10,12,13</b><br><i>Vaccinium myrtillus</i> -type and inferior.                    | 1.5 | 2.0 | 2.6 | 3.1 | 3.8 | 4.5 | 5.3 | 6.1 | 7.0 | 8.0 | -    | -    | -    | -    |
|               | <b>D-County 14-31</b>   | -   | -   | -   | 3.6 | 4.4 | 5.2 | 6.0 | 6.9 | 7.9 | 9.0 | 10.1 | 11.3 | 12.6 | 13.9 |

\* Compare map to d-counties on the next page, figure 5.5!

5.2 Ståndortsinventering – Variabler i meny Ståndort  
5.2 Site inventory — Variables in Menu Site

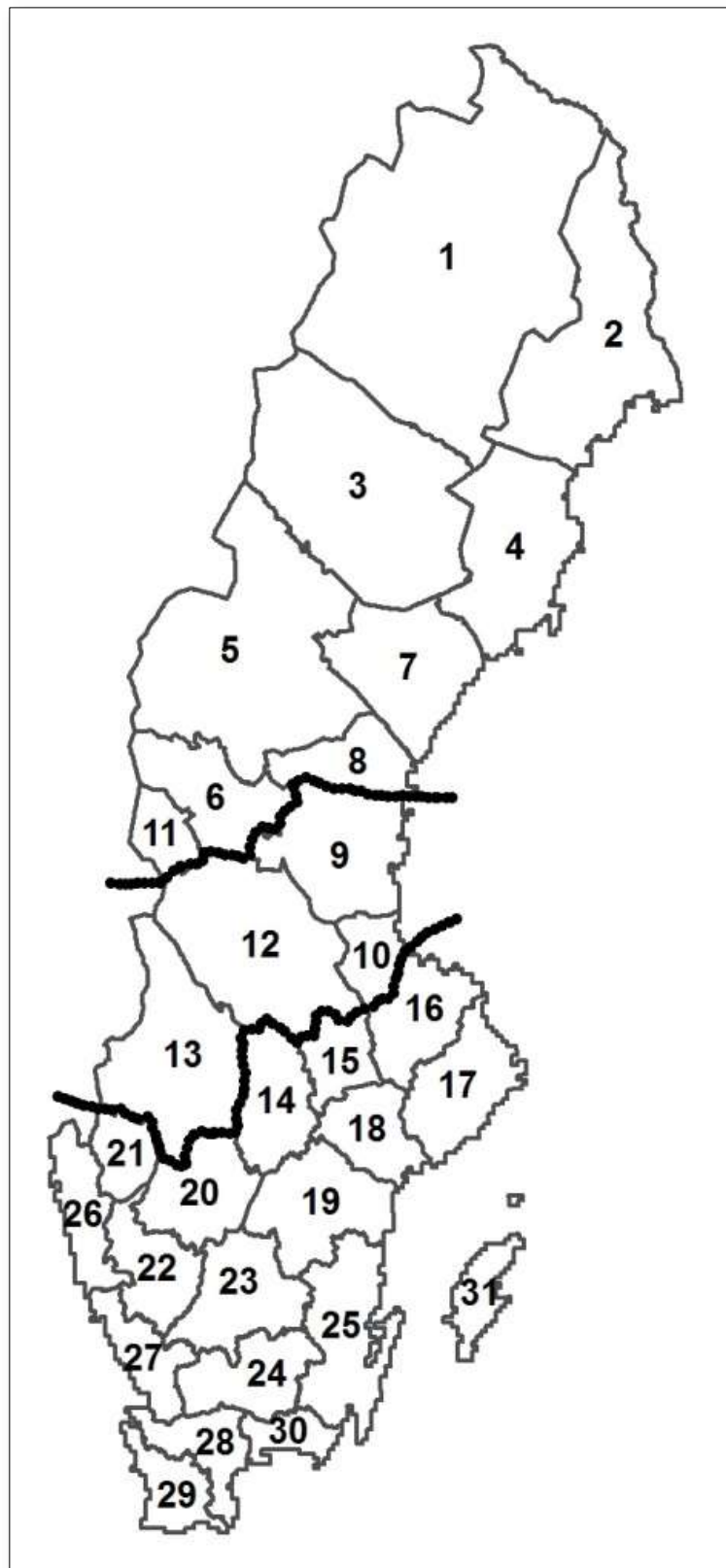

**Fig. 5.5** Area subdivision in the pine and spruce table on the previous page. D-counties in plain text see section 3.4.2.

## 5.3 TREE-LAYER, BUSH-LAYER, GAME-FODDER, MOOSE-DROPPINGS AND BORED TREE

### 5.3.1 VARIABLES IN THE MENU TREE LAYER

Total basal area is indicated for all living trees on the 20 m radius regardless of layer affiliation.

The tree layer description on productive woodland should show how the trees are distributed in different height layers on the 20 m radius. Tree layers means a number of trees, which among themselves are approximately equal in height, but the average height of which deviates from that of other layers.

The minimum height deviation between two layers is determined by the average height of the highest of these layers:

- $\geq 10$  m layer height:  $> 1/3$  of the height of the highest layer.
- $< 10$  m layer height: in accordance with the chart below.

The requirement for height difference between two layers applies to all strata except in the case one of two layers is an upper layer consisting of trees with tree-class “over storey trees”.

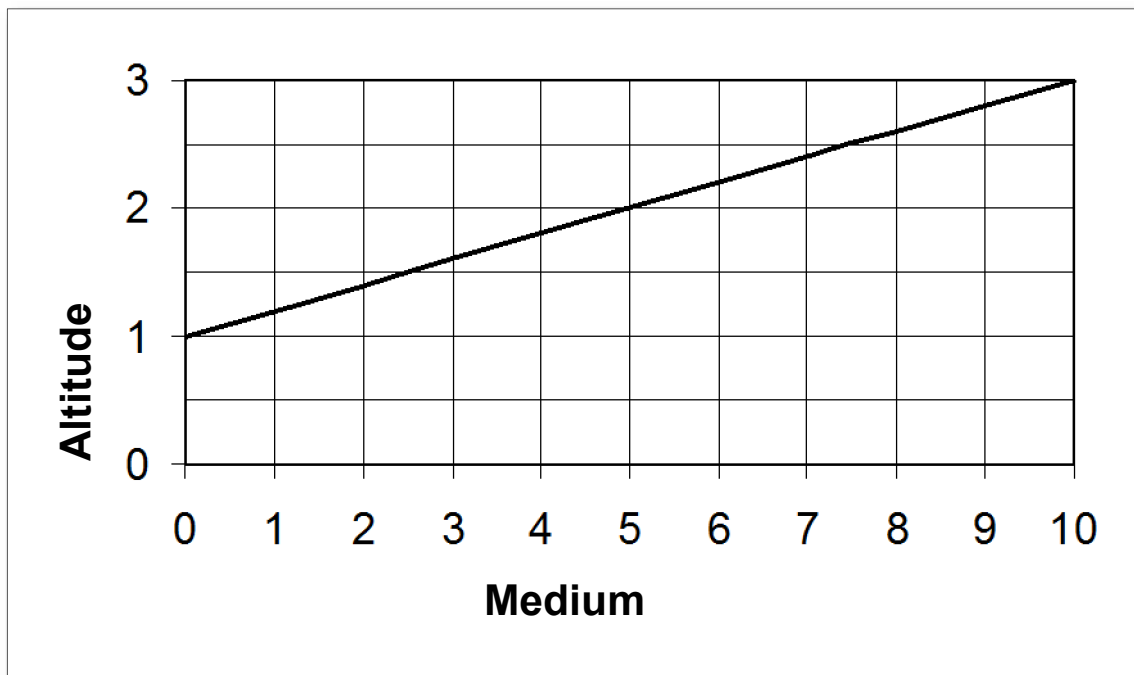

**Fig. 5.6** Minimum requirements for height deviation between two layers where the average height of the highest layer is lower than 10 m.

Please note that the assessment is made independently of the *stand* description established for the felling class determining stand in a specific menu. In some cases, the felling class determining stand, based on the requirements set out here, may be divided into two or possibly more layers of trees, which must then be described.

In particular, note that a main layer is not always made up of the trees which are part of the felling class-determining stand.

If the trees on the 20 m plot are only to be attributed to one layer, this shall also be recorded as certain definitions are not consistent with those applicable to the stand description. Where the felling class-determining layer consists of untouched B forest, the constituent trunks are usually described as one layer, the main layer.

A maximum of three different tree layers can be described. In case of more than three layers, adjacent layers are merged.

Except for upper layers and residues, a tree layer shall be described if one of the following criteria is met:

- Basal area  $\geq 5 \text{ m}^2/\text{ha}$
- Trunk count  $\geq 500/\text{ha}$  (i.e., layer height  $\geq 7 \text{ m}$  can give basal area  $< 5 \text{ m}^2/\text{ha}$ )

At low trunk counts, the trees must not stand too concentrated. In all layers except for main layers, upper layers of medium height above 7 m and stand residues, trees should be found in all the quadrants of the 20-metre plot. Only tree individuals having a height of at least 1 dm are included in the stem count.

For “upper layer” with a layer height  $< 7 \text{ m}$ , the minimum requirement for stem count is 200 stems/ha. An upper layer with a layer height  $\geq 7 \text{ m}$  and density of at least 10 stems/ha is always considered as a tree layer even if the basal area is below  $5 \text{ m}^2/\text{ha}$ . The trees in an upper layer should be reasonably evenly dispersed. (10 stems/ha corresponds to a basal area of  $0.5 \text{ m}^2/\text{ha}$  for 25 cm trees). In addition, the number of trees within the area, covered by an upper layer, must consist of at least 5 trees.

For “stand residue”, the minimum requirement for stem count is 200 stems/ha. In addition, the trees in a stand residue need not be evenly dispersed.

### 5.3.1 Site inventory — Variables in menu Tree Layer

If several lower layers, each individually, fail to meet the density requirement, they are weighed together and described as one layer if the density requirement is thus met. This layer is classed as “other lower layer”.

Tree layers should also be described on *natural grazing*, *morass*, *rock*, *subalpine conifer woodland* and *high mountains*. Here, however, only one layer is described and this is called *the main layer*. If this has an average height above 7 m, the basal area of the main layer and the total basal area should be the same. Furthermore, there is no minimum limit for basal area or stem count, but if there is a tree  $\geq 1.3$  m, a layer is described. The description includes only trees  $\geq 1.3$  m. If several layers are present, they are weighed together in the description.

Absence of a tree layer is specified by selecting “*absence of tree layer*” when the menu opens.

**TOTAL BASAL AREA**

20 m radius

Basal area of all living trees (m<sup>2</sup>/ha)

Codes: 0-99

The total basal area of all living trees is always indicated. Method for determining the basal area is described in Chapter 6, *the basal area of the stand*.

Relascopes cannot be used if the arithmetic average diameter is small. Basal area can then be obtained by using the following auxiliary table. In the table, arithmetic average diameter and stem count/ha are used to obtain a value on basal area/ha.

| Diameter (cm) | Stem count |      |      |      |       |       |
|---------------|------------|------|------|------|-------|-------|
|               | 1000       | 2000 | 3000 | 5000 | 10000 | 20000 |
| 1             | 0.1        | 0.2  | 0.2  | 0.4  | 0.8   | 1.6   |
| 2             | 0.3        | 0.6  | 0.9  | 1.6  | 3.1   | 6.3   |
| 3             | 0.7        | 1.4  | 2.1  | 3.5  | 7.1   | 14.1  |
| 4             | 1.3        | 2.5  | 3.8  | 6.3  | 12.6  |       |
| 5             | 2.0        | 3.9  | 5.9  | 9.8  |       |       |
| 6             | 2.8        | 5.7  | 8.5  | 14.1 |       |       |
| 7             | 3.8        | 7.7  | 11.5 |      |       |       |

**Fig. 5.7** Auxiliary table for conversion of stem count/ha and medium arithmetic diameter to basal area per hectare.

**FOTYPE**

20 m radius

| Code | Type of layer                                      |
|------|--|
| 1    | Main layer   |
| 2    | Upper layer  |
| 3    | Stand residue                                      |
| 4, 6 | Clearly separated lower layer (2 may be specified) |
| 5    | Other lower layer                                  |
| 7    | Fully layered                                      |

Main Layer:

On unproductive woodland, all stems over 1.3 m are included.

In productive woodland, the highest layer of the plot is included excluding the upper layer and stand residue. Note that in some cases, main layers may be absent, for example, after final felling there may be only one upper layer or only a layer of stand residues.

Upper layers are made up of seed trees, screen trees, other over storey trees or other single trees which are not considered stand residue. Trees left after a final felling are classed as upper layer if they belonged to tree classes 1, 2, 3 or 7 of the former stand. The closeness must not exceed 0.3 on the 20 m plot. IF the closeness exceeds 0.3, the layer is classified as the main layer.

The stand residue consists of trees > 1.3 m remaining after final felling and belonging to tree classes 4, 5 or 6 of the former stand. However, an approved stand rejuvenation is classified as the main layer. The stand residue is only indicated in MC A1-B2. In the other MC, it is classified as upper layer or included in the main layer.

A lower layer is a layer lower than the main layer of the sample plot. Clearly demarcated lower layer refers to a clearly discernible lower layer with a small height spread. If the average height of the layer is 10 m or higher, the trees in the layer should be in the range average height of  $\pm 20\%$ . If the average height is less than 10 m, the trees in the layer shall be in the range of average height  $\pm 2$  m. Two layers of the type *clearly demarcated* may be indicated.

Other lower layer refers to a lower layer with greater height spread than a clearly demarcated lower layer, and where clear concentration of stems to a certain height is absent.

A special form of layer is the so-called full-layered forest. For a stand to be classified as fully layered, the following requirements must be met:

Trees must be present in all diameter classes (DKL1-DKL4) as set out in figure 5.7 below. The diameter of the thickest tree ( $D_{max}$ ) shall be at least 200 mm.

For the stem count ( $n_1$ - $n_4$ ) of the different diameter classes,  $n_1 > n_2 > n_3 > n_4 > 0$  shall apply. Further, the mass closeness should be at least 0.5.

In a fully-layered forest, the dimensional and height spread of trees is very large. Often groups of similar trees occur. A typical multi layered forest should be full-layered.

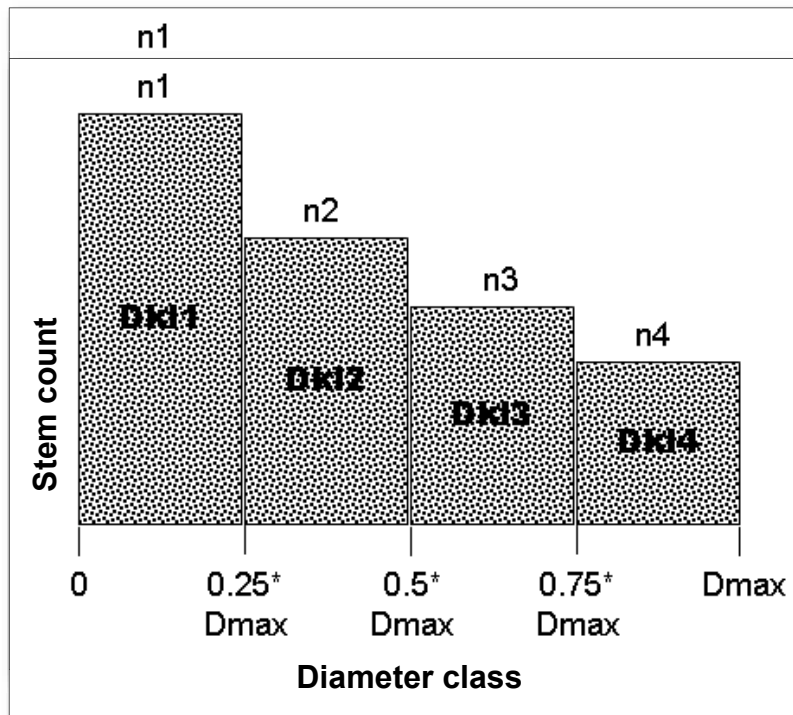

Fig. 5.7 Auxiliary chart for "fully-layered forest".

## SKHÖJD

20 m radius

Medium height of the layer (dm)

Codes: 1-500 (on productive woodland)

13-500 (on natural grazing, morass, rock, subalpine conifer woodland and high mountains)

The average height is determined either as basal area weighted average height or as arithmetic average height. In the assessment, all live trees are included in the layer.

If the basal area weighted average height is 70 dm or higher, the average height is determined as the basal area weighted average height.

For layers where the basal area weighted average height as above is lower than 70 dm, the average height is determined as an arithmetic



average height.

### **SKSTA**

20 m radius

Stem count of the layer (hundreds of stems/ha)

Codes: 2-99 (*upper layer and stand residue*)

5-99 (*main and lower layer of productive woodland*)

1-99 (*non-productive woodland*)

If the average height of the layer is less than 70 dm, the *stem count per hectare* is recorded. A stem count of 10000 or more is recorded with the code "99". The assessment includes all live trees in the layer, including any stubble shoots. Only trees  $\geq 20$  mm are counted at breast height for *Sorbus aucuparia* and *Salix caprea*. Fewer stems than 100/ha are indicated by the code '1' on non-productive woodland. Absence of trees is indicated as *absence of tree layers*. The assessment of the number should be based on the counting of stems on a number of support plots with radius 3.5 m (3.5 m rod used), normally five. Auxiliary tables for determining stem count are found under the Closeness variable in section 6.3.

### **SKGRY**

20 m radius

Basal area of the layer ( $\text{m}^2/\text{ha}$ )

Codes: 0-99

If the average height of the layer is 7 m or higher, the basal area *of the layer* is indicated. In the assessment, all live trees are included in the layer.

### **ÖVSTANT**

20 m radius

Number of over storey trees

Codes: 0-50

If the layer type is specified to the “upper layer”, the *number of* over storey trees on the 20 m plot shall be indicated. For the definition of over storey tree, see section 8.2. If there is a dividing line within the plot, a markup is made so that the number indicated corresponds to a whole 20 m plot.

## **LAYER AGE**

20 m radius

Tree Layer Age (years)

Codes: 25-500

For reserve volume plots not classified as productive forestland, the population age is not specified in the stand description. However, an age of the tree layer should be indicated if a tree layer is described. This is determined as the total age of trees  $\geq 1.3$  m.

If the basal area weighted average height of the tree layer of 20 m plot is 70 dm or higher, the age is determined as the basal area weighted average age.

For tree layers where the basal area weighted average height is less than 70 dm, the age is determined as an arithmetic average age for trees  $\geq 1.3$  m.

The age is determined by boring at least one tree. The total age of a tree is determined by adding to breast height the time needed for a tree to reach 1.3 m. We use a flat rate supplement for this of 25 years.

## **TREE SPECIES AND PROPORTION**

20 m radius

The tree species composition of a layer is indicated by selecting “*Edit tree species proportion*” when pressing “Enter” on a registered layer.

## **TREE SPECIES**

Tree species, see Annex B9.

## PROPORTION

Tree species proportion (%)

Codes: 1-100

The assessment includes all live trees with the exception of *Sorbus aucuparia* and *Salix caprea* < 20 mm in breast height.

If the medium height of the layer has been determined as the basal area weighted average height (average height  $\geq$  70 dm), the tree species composition is indicated as a percentage of the basal area . Where average height has been determined as an arithmetic average height, the tree species composition is indicated as a percentage of total stem count. Presence of a tree species is indicated by registering 1%.

## 5.3.2 VARIABLES IN THE MENU SHRUB LAYER

### SHRUB SPECIES

7/10 m-radius

Presence of shrubs

| Code | Shrub species             | Code | Shrub species                                       |
|------|---------------------------|------|---|
| 1    | <i>Betula nana</i>        | 9    | <i>Crataegus/Prunus</i>                             |
| 2    | <i>Salix species</i>      | 10   | <i>Rose species</i>                                 |
| 3    | <i>Juniperus communis</i> | 11   | <i>Rhamnus frangula</i>                             |
| 4    | <i>Raspberry</i>          | 12   | <i>Lonicera xylosteum</i>                           |
| 5    | <i>Sorbus aucuparia</i>   | 13   | <i>Myrica gale</i>                                  |
| 6    | <i>Prunus padus</i>       | 14   | <i>Viburnum opulus/Ribes spicatum/Ribes alpinum</i> |
| 7    | <i>Corylus avellana</i>   | 15   | <i>Daphne mezereum</i>                              |
| 8    | <i>Sambucus nigra</i>     | 16   | <i>Other shrub species</i>                          |

Presence of species is indicated independently of the total cover of the shrub layer. In the absence of shrubs, this is indicated by selecting '*Absence of shrubs*' when the menu opens.

For the shrub layer, all shrubs are included unless they are considered trees in accordance with Annex B9. *Row* and *Salix caprea* with a diameter  $\geq 20$  mm are included in the tree layer, as are other normally shrub-shaped species if they have a diameter  $\geq 50$  mm and a reasonably straight stem shape.

→ Note that *Salix caprea* and *Sorbus aucuparia* < 20 mm are included in the shrub layer.

*Ribes uva-crispa* are included in the group *Viburnum opulus/Ribes spicatum/Ribes alpinum*. *Salix reticulata*, *Salix herbacea*, *Salix polaris* and *Salix xarctogena* are not included in the group of *salix* species. These are not included at all in the description of shrubs. All existing species/species

groups are specified.

*Other shrubs* includes, for example, *Amelanchier spicata*, *Cotoneaster*, *Symphoricarpos albus*, *Aronia*, *Ligustrum vulgare*, *Hedera helix* and *Lonicera caprifolium*.

## TÄCKNING

7/10 m-radius

Cover of shrub species, m<sup>2</sup>

Codes: *Temporary reserve area 0-154*

*Permanent reserve area 0-314*

The covering of the shrub layer is indicated in m<sup>2</sup>. Cover is determined as so-called diffuse cover (see Annex B8). Class average value is recorded, thus rounding to the nearest whole m<sup>2</sup>. For example, the 3 m<sup>2</sup> class includes 2.5 - 3.4 m<sup>2</sup>. The class 0 m<sup>2</sup> includes > 0 - 0.5 m<sup>2</sup>.

### 5.3.3 VARIABLES IN MENU GAME FORAGING

The presence, cover and grazing pressure of the species used as game feed must be indicated. The assessment refers to the height range 0.3 — 2.5 m. Please note that for *Salix caprea* and *Sorbus aucuparia* species, this means the total cover within the height range (the sum of cover in both shrub and tree layer). *Juniperus communis* is recorded both in menu Shrub layer and in menu Game forage.

The cover of game forage is assessed in the same way as bush layer cover. The assessment includes game forage in the form of twigs, branches and small trees, available from 0.3 m to 2.5 m above ground level. In the absence of game forage, this is indicated by selecting '*Absence of game forage*' when the menu opens.

The cover of game forage refers to all available shoots regardless of the age of the shoot. Grazing pressure is assessed by rating the grazing rates of the shoots grown in Season 1.

#### GAME FORAGE SPECIES

7/10 m-radius

Game forage species

*Pine*

*Birch*

*Populus tremula*

*Quercus robur*

*Fraxinus excelsior*

*Pinus contorta*

*Sorbus aucuparia*

*Salix*

*Juniperus communis*

## GAME COVER

7/10 m-radius

cover of game feed species, m<sup>2</sup>

Codes: *Temporary plots* 0-154

*Permanent plots* 0-314

The game forage cover is indicated in m<sup>2</sup> and refers to the cover of all shoots regardless of age on the shot. Class average value is recorded, thus rounding to the nearest whole m<sup>2</sup>. For example, the 3 m<sup>2</sup> class includes 2.5 - 3.4 m<sup>2</sup>. The class 0 m<sup>2</sup> includes > 0 - 0.5 m<sup>2</sup>.

## GRAZING?

7/10 m-radius

Does grazing occur on shoots grown in season 1 to an extent as described below?

Codes: Yes  
No

The assessment is done for the 7/10 m radius. Each individual square metre within a species' game feed cover is classified as grazed or not grazed. For a square metre to be classified as grazed, more than 10 % of its shoots that have emerged in season 1 must have been grazed, irrespective of the time of grazing. Is any square metre classified as grazed recorded Grazing? = yes. The assessment is made for each recorded game feed species. The assessment is not done on the land use class of *natural pasture*.

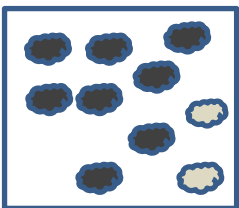

**Fig. 5.8** *Blanket feed cover refers to all available shoots regardless of the age of the shoots and is symbolized by everything that fits within the square. Non-grazed shoots grown in season 1 is symbolized by black “clouds”. Grazed shoots grown in season 1 are symbolized by gray “clouds”. This square metre of forage should thus be classified as grazed!*

Two special cases occur:

- If any shoot on *Juniperus communis* is grazed, Grazing?=yes and no further registration needs to be made.
- If the other game forage species were recorded with cover code 0 or 1, then the species should be classified with Grazing? =yes if more than 10% of season-1 shoots are grazed and no further registration needs to be made.

### **GRAZED AREA**

7/10 m-radius

Cover of game forage classified as grazed, m<sup>2</sup>

Codes: 1- *Game forage species cover*

The registration refers to the square meters of a species' game feed cover classified as grazed. For one square metre to be classified as grazed, more than 10% of its shoots grown in season 1 must be grazed, regardless of the time of grazing.

Registered when a game feed species is recorded with cover code > 1.

### **DROPPINGS**

3.5 m radius

Moose dropping piles (number)

Codes: 0-99

The number of *moose droppings piles* is recorded within an area of 3.5 m radius. All piles are counted regardless of age of the droppings. To be counted as a pile, the number of droppings must be at least 20 or an equivalent quantity. Piles on the demarcation line of the plot are counted if the centre of the pile is within the plot. If there are no droppings piles, this is indicated by selecting "*Droppings absent*" when the menu opens.

→ *Please note that registration is made in a separate menu: Moose droppings!*



## 5.3.4 VARIABLES IN MENU BORED TREE

The age registration of “stands” on the land use classes productive forest land, rock, subalpine coniferous woodland and high mountains is important, such as in the context of habitat classification. Permanent sample plots, as a rule, lack age data for individual trees. As a result, the age set for a stand becomes uncertain and therefore can vary widely between inventories. In order to improve and stabilize the age information on P plots, from 2021 we will make the bored tree menu a mandatory menu. It applies to permanent plots on high level productive woodland where the development class is D1 or D2 as well as mountains, subalpine conifer woodland and high mountains. Trees, known as age trees, to be bored should be representative of a specific sub-sample plot, but in the field computer the menu is available at the sample plot level. New age trees should stand at a distance of 101-200 dm from the centre. Re-measured objects can be found at a distance up to 250 dm. If there are existing bored trees, check that they are still there. When counting annual rings, a loupe shall be used, as a rodoid disc shall be used when the marrow is missed. More trees whose age has been determined can always be added. In the absence of trees or where the stand is only made up of tree species with indistinct annual rings this can be marked by selecting '*Absence of suitable trees to bore*' when the menu opens.

### STILL THERE?

Applies only to re-measured objects on permanent plots

Codes: Yes/No

### DIAMETER

Diameter of the sample tree (mm)

Codes: 40-9999

The diameter recorded is diameter at breast height.

### **TREE SPECIES**

Codes for tree species, see Annex B9.

### **AVSTÅND**

Distance to the tree (dm)

Codes: 101-250 (*dm*)

The variable is recorded if the coordinates of a re-measured tree are incorrect as well as in coordinate setting of new trees.

### **RIKTNING**

Direction to the tree (degrees)

Codes: 1-360

The variable is recorded if the coordinates of a re-measured tree are incorrect as well as in coordinate setting of new trees.

### **BRHÅLDER**

Breast height age, years

Codes: 1-999

## **5.4 VARIABLES IN MENU SMALL PLANTS PLOT**

A special inventory of *billberry* and *cowberry* is carried out on volume plots on all tracts. The inventory is carried out on two small sample plots per sample plot. The sample plots consist of 0.25 m<sup>2</sup> circular plots (radius = 0.28 m). The entire area of the small plot shall be inventoried if its centre ends up on sub-sample plots with the land use classes "1,2,4,5,6, 7 and

10. They have a fixed predetermined position, 2.5 m from sample plot centre, 45° and 225° clockwise from regular walking direction, coinciding with the plot centres of the plots used to inventory small trees (compare figure 7.3 of section 7.2). The menu is recorded at sample plot level. Small-sample areas are not shared, sub-sample plot identity is determined by the plot centre of the small sample plot.

The small sample plots have number 1 and number 3. plot 1 is obliquely forward right in the regular walking direction and plot 3 is obliquely backward left. The choice of plot to register is made in the menu overview.

Registrations relate to occurrence, stage of development, number of berries and for *Vaccinium myrtillus*, additionally, vegetation height.

If both *Vaccinium myrtillus* and *Vaccinium vitis-idaea* are missing on the plot, this is highlighted by selecting “Species missing” when the menu opens.

## SPECIES

0.28 m radius

| Code | Arts/Species Group |
|------|--------------------|
|------|--------------------|

42



43



|    |                              |
|----|------------------------------|
| 42 | <i>Vaccinium vitis-idaea</i> |
| 43 | <i>Vaccinium myrtillus</i>   |

The records relate to the presence of species having an above-ground plant part within the demarcation line of the sample area. One species is noted whether it lives or has been alive during the current vegetation period.

## VEGHÖJD

0.28 m radius



Vegetation height (cm)

Codes: 0-99

The *height of the Vaccinium myrtillus* plant is measured in cm and refers to the average height on the plot. Rounding is to the nearest centimeter.

## UTVECKLINGSSTAD

0.28 m radius



Code Stage of development of *Vaccinium myrtillus* and *Vaccinium vitis-idaea*

- |   |   |
|---|---|
| 1 | <i>Before blooming ("Spring stage")</i> |
| 2 | <i>Blooming</i>                         |
| 3 | <i>Unripe</i>                           |
| 4 | <i>Ripe berry</i>                       |
| 5 | <i>Berries have fallen off</i>          |

The variable is recorded when *Vaccinium myrtillus* or *Vaccinium vitis-idaea* plants occur. '*stage of development*' refers to the conditions on the sample plot. Where the number is to be counted and there are different stages of development on the sample plot, all must be counted regardless of the stage. In the absence of flowers or berries on the veg plot, code is set for development using what is observed/has been observed in the vicinity of the sample plot. Code "1" implies "spring stage", i.e. that flowering is not yet underway for the season.

→ *The same stage of development shall be set on both small sample plotss of the sample plot.*

### **1** *Before flowering ("spring stage")*

Most of the buds have not flowered.

### **2** Flowering

Most of the buds have flowered and the number of flowers exceeds the number of unripe fruits.

### 3 *Unripe fruit*

Most of the flowers have transitioned to unripe fruit and the number of unripe fruits exceeds the number of ripe berries. Unripe fruit is defined by the fact that the petals have fallen off and the fruit substance started to grow.

### 4 *Ripe berries*

Most of the unripe fruit has ripened and the number of ripe berries remaining exceeds the number of berries fallen off.

### 5 *The berries have fallen off*

Most of the berries have fallen off.

## **ANTBLOM**

0.28 m radius



Number of flowers/berries

Codes: 0-999

The variable is recorded when *Vaccinium myrtillus* or *Vaccinium vitis-idaea* plants are present and Development stage is set to code '4'. If there are more than 999 berries, code "999" is recorded.

When counting ripe berries, everything should be included. You should therefore count the specimens that are still flowers or unripe fruit, the ripe berries, as well as those which may have fallen off.

## 6 AREA INVENTORY

### 6.1 GENERAL

Area inventory is carried out on volume sample plots on the land use classes *productive forest land (01)*, *natural pasture (02)*, *morass (04)*, *rock and certain other impediments (05)*, *subalpine coniferous woodland (06)* and *high mountains (07)*. Measures carried out are also registered on the land use classes *arable land*, *roads and railways*, *power lines* and *other land*. The description mainly refers to a circular surface with a radius of 20 m. Some elements, however, refer to the stand, an area with a radius of 10 m, or a small sample plot for caliper measurement of tree diameter in breast height (dbh) with a radius of 3.5 m. Note that if the dividing boundary is within the 20 m surface, the description of the 20 m surface refers only to the part that is within the same part of the stand as the described sample plot/sub-sample plot with a radius of 10 m. Variables included in the area inventory are registered in the menus **Location 7 / 10-25 m**, **Land use**, **Stand description**, **International land use class**, **Stand damage** and **Action taken**. A special moose grazing inventory has also been included in the area inventory, which is carried out in young forests on productive forest land. Registration is done in a special menu called **ÄBIN**. The Location 7/10-25 m menu is made at the level of the sample plot, while the other menus are carried out at the sub-sample plot level.

The elements of the area inventory and description units to which different elements refer are set out below:

| <b>Step/variable</b>                              | <b>Description unit</b> | <b>See page</b> |
|---|-------------------------|-----------------|
| <b>6.2 Location 7/10-25 m</b> .....               | -                       | 6:9             |
| Adjacent land use classes ( <b>ANGR ÄGOSLAG</b> ) | Within 25 m             | 6:9             |
| .....   |                         |                 |

|  |              |      |
|--|--------------|------|
| Maturity class in adj. stands ( <b>HKLANG</b> ) .....  | Within 25 m  | 6:11 |
| Stand height in adj. stands ( <b>MEDELHÖJD</b> ) ..... | Within 25 m  | 6:11 |
| Year when stand edge arose ( <b>KANTÅR</b> ) .....     | Within 25 m  | 6:12 |
| Direction to adj. stand ( <b>RIKTNING</b> ) .....      | Within 25 m  | 6:12 |
| <b>6.3 Land use</b> .....                              | -            | 6:13 |
| Other land use ( <b>ANNAN MARKANV</b> ) .....          | 20 m surface | 6:13 |
| Impact on forestry ( <b>INV SKOGSBR</b> ) .....        | 20 m surface | 6:17 |
| Previous land use ( <b>TID MARKANV</b> ) .....         | 20 m surface | 6:19 |

cont. →

| <b>Step/variable</b>  | <b>Description unit</b> | <b>See page</b> |
|---|-------------------------|-----------------|
| <b>6.4 Stand description</b> .....                                  | -                       | 6:21            |
| Maturity class ( <b>HUGGKLASS</b> ) .....                           | The stand               | 6:21            |
| The surface area of the stand<br>( <b>BESTÅNDSAREAL</b> ) .....     | The stand               | 6:34            |
| Nature conservation considerations<br>( <b>HÄNSYN?</b> ) .....      | The stand               | 6:36            |
| Type of consideration ( <b>TYP AV HÄNSYN</b> ) .....                | The stand               | 6:38            |
| Date of consideration .....   |                         |                 |
| ( <b>TIDPUNKT FÖR HÄNSYN</b> ) .....                                | The stand               | 6:38            |
| Stand height ( <b>MEDELHÖJD</b> ) .....                             | 20 m surface            | 6:39            |
| basal area ( <b>BESTÅNDETS GRUNDYTA</b> ) .....                     | 20 m surface            | 6:40            |
| EQUALITY OF AGE ( <b>LIKÅLDR</b> ) .....                            | 20 m surface            | 6:43            |
| Stand age ( <b>BESTÅNDSÅLDER</b> ) .....                            | 20 m surface            | 6:44            |
| Stand character ( <b>BESTKAR</b> ) .....                            | 20 m surface            | 6:48            |
| Tree species mixture ( <b>TRÄDSLAG, ANDEL</b> ) ..                  | 20 m surface            | 6:50            |
| Proposed action and deadlines.<br>( <b>ÅTGÄRD, FTID</b> ) .....     | The stand               | 6:53            |
| Canopy cover ( <b>KRONTÄCKN</b> ) .....                             | 20 m surface            | 6:56            |
| Number of dominating + co-dominating<br>( <b>ANT HÄ+MHÄ</b> ) ..... | 20 m surface            | 6:57            |
| Number of main plants ( <b>ANTAL HPL</b> ) .....                    | 20 m surface            | 6:58            |
| Closeness unit ( <b>SLUTENHET</b> ) .....                           | 20 m surface            | 6:63            |
| Looseness ( <b>LUCKOR</b> ) .....                                   | 20 m surface            | 6:69            |
| <b>6.5 International land use class</b> .....                       | -                       | 6:73            |

|  |              |      |
|--|--------------|------|
| International land use class ( <b>INTÄGO</b> ).....                  | 20 m surface | 6:73 |
| <b>6.6 Stand damage</b> .....  | -            | 6:75 |
| Damage to living tree stands ( <b>SKAD LEV?</b> )....                | 20 m surface | 6:77 |
| Degree of damage liv. tree stand.<br>( <b>SKADEGR LEV</b> ).....     | 20 m surface | 6:78 |
| Dominant cause of damage ( <b>DOM SKADORS</b> )                      | 20 m surface | 6:79 |
| .....  |              |      |
| Damage within 5 years? ( <b>SKAD INOM 5 ÅR?</b> )                    | 20 m surface | 6:81 |
| Cause of damage for damage within 5 years<br>( <b>SKADORS</b> )..... | 20 m surface | 6:82 |
| Proportion of damaged stems for damage within<br>5 years .....       |              |      |
| ( <b>SKADEANDEL</b> ).....   | 20 m surface | 6:82 |
| Proportion of damaged stems season 0-1 .....                         |              |      |
| ( <b>ANDEL NYA</b> ).....  | 20 m surface | 6:83 |

cont. →

| <b>Step/variable</b>   | <b>Description unit</b> | <b>See Page</b> |
|--|-------------------------|-----------------|
| Percentage of dead stems season 0-1 .....                                  |                         |                 |
| ( <b>ANDEL DÖDA</b> ).....   | 20 m surface            | 6:83            |
| Date of damage season 0-1 .....  |                         |                 |
| ( <b>SKADETIDPUNKT</b> ) .....   | 20 m surface            | 6:84            |
| Reduced maturity class? ( <b>NEDSATT?</b> ) .....                          | 20 m surface            | 6:84            |
| Cause of damage for reduced maturity class<br>( <b>SKADORS NEDS</b> )..... | 20 m surface            | 6:86            |
| Previous maturity class ( <b>TID HUGGKLASS</b> ).                          | 20 m surface            | 6:86            |
| Date of damage that led to .....   |                         |                 |
| reduced stand ( <b>TID NEDS</b> ) .....                                    | 20 m surface            | 6:87            |
| <b>6.7 Action taken</b> .....  | -                       | 6:88            |
| Action taken ( <b>UÅTGÄRD</b> ) .....                                      | 20 m surface            | 6:91            |
| Date of action taken ( <b>TIDPUNKT</b> ) .....                             | 20 m surface            | 6:100           |
| Tree species in forestry ( <b>ODLTRSL</b> ).....                           | 20 m surface            | 6:102           |
| Cause of felling ( <b>ORSAK AVV</b> ) .....                                | 20 m surface            | 6:102           |
| Cause of damage in case of felling during<br>decontamination .....         | 20 m surface            | 6:104           |



|   |              |       |
|---|--------------|-------|
| ( <b>SKADEORS AVV</b> ).....                        |              |       |
| Withdrawal of energy range? ( <b>ENERGI?</b> )..... | 20 m surface | 6:104 |
| Age of felled trees ( <b>ÅLDER AVV</b> ).....       | 20-m         | 6:106 |
|   | surface      |       |
| <b>6.8 Moose grazing inventory</b> .....            | -            | 6:107 |
| <b>6.8.1 General</b> .....                          | -            | 6:107 |
| <b>6.8.2 Variables</b> .....                        | -            | 6:109 |
| Stand height ( <b>MEDELHÖJD</b> ).....              | 3.5 m        |       |
|   | surface      | 6:109 |
| Fresh damage to pine ( <b>FÄRSK TALL</b> ).....     | 3.5 m        |       |
|   | surface      | 6:109 |
| Fresh and old damage to pine .....                  | 3.5 m        |       |
| ( <b>FÄRSK/GAM TALL</b> ) .....                     | surface      | 6:111 |
| Old damage to pine ( <b>GAMMAL TALL</b> ).....      | 3.5 m        |       |
|   | surface      | 6:112 |
| Other damage to pine ( <b>ÖVR SKADOR TALL</b> )     | 3.5 m        |       |
|   | surface      | 6:113 |
| Undamaged pines ( <b>OSKADAD TALL</b> ).....        | 3.5 m        | 6:113 |
|   | surface      |       |
| Fresh grazing on <i>Betula pendula</i>              | 3.5 m        |       |
| ( <b>F SKAD VBJÖ</b> ).....                         | surface      | 6:114 |

cont. →

| <b>Step/variable</b>                                | <b>Description unit</b> | <b>See Page</b> |
|---|-------------------------|-----------------|
| No fresh grazing on <i>Betula pendula</i> .....     | 3.5 m                   |                 |
| ( <b>EJF SKAD VBJÖ</b> ).....                       | surface                 | 6:115           |
| Fresh grazing on <i>Betula pubescens</i>            | 3.5 m                   | 6:115           |
| ( <b>F SKAD GBJÖ</b> ).....                         | surface                 |                 |
| Not fresh pickling on <i>Betula pubescens</i> ..... | 3.5 m                   |                 |
| ( <b>EJF SKAD GBJÖ</b> ) .....                      | surface                 | 6:116           |

## 6.2 LOCATION 7 / 10-25 M

Nedan beskrivs de variabler som registreras för att beskriva provytans (7 eller 10 m-yta) läge i förhållande till den närmaste omgivningen inom 25 m. I menyn registreras endast de bestånd och ägoslag som inte framgår av övriga beskrivningar på påslaget. På produktiv skogsmark kan anges *angränsande ägoslag* och *angränsande bestånd*. På övriga ägoslag anges endast *angränsande ägoslag*.

Below is a description of the variables that are registered to describe the location of the sample plot (7 or 10 m surface) in relation to the immediate surroundings within 25 m. Only the stands and land use classes that are not included in other descriptions of the sample plot is registered in the menu. On productive forest land, *adjacent land use classes* and *adjacent stands* can be specified. On other land use classes, only *adjacent land use classes* are specified.

**ANGR ÄGOSLAG**

| Code | Adjacent land use classes               | Code | Adjacent land use classes                       |
|------|---|------|---|
| 1    | <i>Productive forest land</i>           | 9    | <i>Road and rail</i>                            |
| 2    | <i>Natural pasture</i>                  | 10   | <i>Power line within productive forest land</i> |
| 3    | <i>Arable land</i>                      | 13   | <i>Developed land</i>                           |
| 4    | <i>Morass</i>                           | 14   | <i>Other land</i>                               |
| 5    | <i>Rock and some others impediments</i> | 15   | <i>Freshwater</i>                               |
| 6    | <i>Subalpine coniferous woodland</i>    | 16   | <i>Saltwater</i>                                |
| 7    | <i>High mountains</i>                   |      |   |

One and the same land use class can be specified only once. If the same land use class occurs in several different directions, the closest is stated.

**HKLANG**

Code Maturity class adjacent stands

|    |    |    |    |    |    |
|----|----|----|----|----|----|
| 11 | A1 | 31 | C1 | 41 | D1 |
| 21 | B1 | 32 | C2 | 42 | D2 |
| 22 | B2 | 33 | C3 | 51 | E1 |
| 23 | B3 | 34 | C4 |    |    |

If the stand boundary is within 25 m, the maturity class for the adjacent stand must be specified. One and the same maturity class can be specified only once. If there are stands with the same maturity class in several directions, indicate the one that is closest.

**MEDELHÖJD**

Average height (dm)

Codes: 0-500

**KANTÅR**

Code Date when stand edge arose

|   |   |
|---|---|
| 1 | <i>The edge originated less than 5 years ago</i>  |
| 6 | <i>The edge originated 5 years ago or earlier</i> |

For adjacent stands, it must also be stated when the stand edge arose. If a final felling has taken place in the current or adjacent stand, the edge is considered to have arisen in connection with the felling, even if there has been a stand edge there for a long time.

**RIKTNING**

Direction to adjacent stands (degrees)

Codes: 1-360

Riktning till angränsande bestånd från ytcentrum anges i grader.  
Direction to adjacent stands from the surface centre is given in degrees.

## 6.3 LAND USE

The variables included in the Land Use menu are described below.

### **ANNAN MARKANV**

20 m-ytan

### **ANNAN MARKANV**

20 m surface

*Other land use* is specified according to the following classes:

| Code | Other land use   |
|------|--|
| 0    | <i>None</i>  |
| 2    | <i>Game fence / reindeer fence</i>                               |
| 3    | <i>Grazing for domestic animals</i>                              |
| 4    | <i>Recreation area</i>   |
| 5    | <i>Military training area</i>                                    |
| 6    | <i>Technical impediment</i>                                      |
| 7    | <i>Other productive forest land which is difficult to access</i> |
| 8    | <i>Other</i>   |

A type of other land use may be specified. If there are several, the one with the most impact on forestry is specified.

#### **0** *None*

No other land use

#### **2** *Game fence / reindeer fence*

Specify if the sample plot is within a game enclosure, or if it is within a reindeer enclosure used in connection with e.g. calf marking.

#### **3** *Grazing for domestic animals*

The extent of grazing is decisive for whether a sample plot is to be classified as productive forest land with grazing or as natural grazing. If

grazing occurs to such a limited extent that forest production is the main land use, the area is classified as productive forest land with grazing. If the pasture is continuous and the tree layer is heavily sparse to promote grass and herb growth, the sample plot should be classified as *natural pasture*. For other land use classes, grazing is specified if it occurs. Öland's alvar and similar areas, which are classified as *rock and other impediments*, are often used for grazing.

### **4** *Recreation area*

Almost all productive forest land is used to some extent for recreational purposes. However, the sample plot should be classified as recreational forest only if there are indications that the forestry measures have been adapted to promote the forest's values from a recreational perspective. This is often the case in connection with urban areas or in areas adjacent to sports and exercise facilities. Recreational forest is only specified on productive forest land.

### **5** *Military training area*

This code is used in military training areas.

### **6** *Technical impediment*

is indicated if the sample plot is within an area that is deemed inaccessible for forestry measures, or accessible only with the use of special (expensive) methods. This is e.g. the case in extremely steep or rocky terrain. Morass islets and islands are not included in this category, as they are usually accessible in winter. Technical impediment is stated only on productive forest land.

### **7** *Other productive forest land difficult to access*

specified for areas where, although productive forest land, due to its location, forestry measures are very difficult. This is e.g. the case for narrow forest strips between roads and railways or in direct connection to buildings. This type of land should therefore not be included in a technical impediment. Prior to 2003, such land was transferred to the land use class "other land". Remote land is not classified as productive forest land that is difficult to access. The code is only specified for productive forest land.

## 8 Other

If conditions other than those mentioned above can be expected to lead to restrictions for practical forestry, this is stated under this category. Well-kept ancient monuments are examples of other land use. The code is only specified for productive forest land.

### INV SKOGSBR

20 m surface

| Code | Impact on forestry        |
|------|---------------------------|
| 1    | <i>None or very small</i> |
| 2    | <i>Moderate</i>           |
| 3    | <i>Major</i>              |

The assessment is made only if other land use has been assigned for *game enclosures, grazing for domestic animals, recreation area, military training area* or *other*. as a basis for the classification, an assessment is made of whether the current land use means that the value of timber production is reduced. The reduction may be due to low closeness, looseness, poor stem selection during cleaning and thinning, extended rotation time, damage, limited opportunity for clear-cutting, etc.

#### 1 *No or very little impact*

Forestry is conducted in a conventional manner. Damage as a result of other land uses occurs to a small extent. Tree species selection and closeness do not deviate in relation to normal forestry.

#### 2 *Moderate impact*

Examples of moderate effects can be the following:

- Forestry is ongoing, but it is reasonable to assume that the rotation time will be extended to promote other land uses.
- Forestry is conducted with multi-layering methods instead of clear-cutting.

- Deciduous trees are given priority over conifers in cleanings and thinning, but forestry is otherwise conducted according to conventional methods.
- Moderate damage has occurred to the stand as a result of other land use.

### 3 *Major impact*

specified in the following situations:

- Significantly extended rotation time.
- The stand is heavily sparse to promote other land use, but will probably be felled at the normal final felling age.
- Stand care severely neglected (rejuvenation, cleaning, thinning) but the stand can be expected to be harvested at normal times.
- Serious damage has occurred to the stand as a result of other land use.

### **TID MARKANV**

20 m surface

*Previous land use* is registered in the following classes:

| Code | Previous land use   |
|------|---|
| 0    | <i>Same as current or none of the following.</i>  |
| 2    | <i>Natural pasture with "Hagmark?" = yes, where the use ceased less than 20 years ago.</i>  |
| 3    | <i>Arable land or natural pasture with "Hagmark?" = no, where the use ceased less than 20 years ago. (Some support for the assessment can be obtained through the age of any tree, &lt;20 years).</i> |
| 4    | <i>Arable land or natural pasture where cultivation ceased more than 20 years ago. The land is not and has not been afforested since the closure.</i>   |
| 5    | <i>Arable land or natural pasture with "Hagmark?" = no, where the use ceased more than 20 years ago. The stand belongs to</i>   |



*the first generation forest, i.e. not bare forest land.*

- 6     *Gravel pit.*
- 7     *Mining.*
- 8     *Peat extraction.*

The variable is registered only on *productive forest land* on temporary sample plots.

## 6.4 STAND DESCRIPTION

The variables included in the Stand Description menu are described below. On land use classes other than productive forest land, only the variable canopy cover is registered.

### HUGGKLASS

The stand

Code Maturity class

|    |    |    |    |    |    |
|----|----|----|----|----|----|
| 11 | A1 | 31 | C1 | 41 | D1 |
| 21 | B1 | 32 | C2 | 42 | D2 |
| 22 | B2 | 33 | C3 | 51 | E1 |
| 23 | B3 | 34 | C4 |    |    |

The *maturity class* expresses the degree of development of a stand. The maturity class is by nature a subjective assessment. It is determined partly based on such properties of the stand that cannot be easily captured with simple variables, e.g. vitality and looseness. The criteria given below for determining the maturity class should therefore not be regarded as mandatory.

If a stand is divided into several layers, the maturity class is normally set on the basis of the highest layer with a stem count or basal area that exceeds the limit for bare forest land. If the highest layer, due to unsuitable tree species (see Appendix B9), low closeness or for other reasons, is substandard for the entire action unit, maturity class is assigned based on

a lower layer, also with stem count or basal area exceeding the limit for bare forest land, if any and thus, for the entire action unit, the quality of the stand is significantly improved.

Layers with an average height lower than 1.3 m consisting of self-rejuvenation or stump shoots of unsuitable tree species or so-called frost screens are never decisive for purposes of maturity class.

The term maturity class is used here somewhat improperly both for rough development classes, designated A, B, C and D, as well as for the actual maturity classes, designated B1, B2, B3, etc.

### Bare forest land (A)

#### **11 Bare forest land (A1)**

Bare forest land refers to forest with a density (number of main stems per hectare) that is less than the bare forest land limit according to the diagrams below (corresponds to h-closeness 0.4). However, if the majority of dominant and co-dominant trees is thicker than 10 cm at breast height, the mass closeness unit 0.3 shall apply as the limit for bare forest land. Managed leaf stands may be allowed to have a closeness below 0.3.

For deciduous tree species, the diagram for pine and contorta pine is applied, and for other tree species the diagram for spruce is applied.

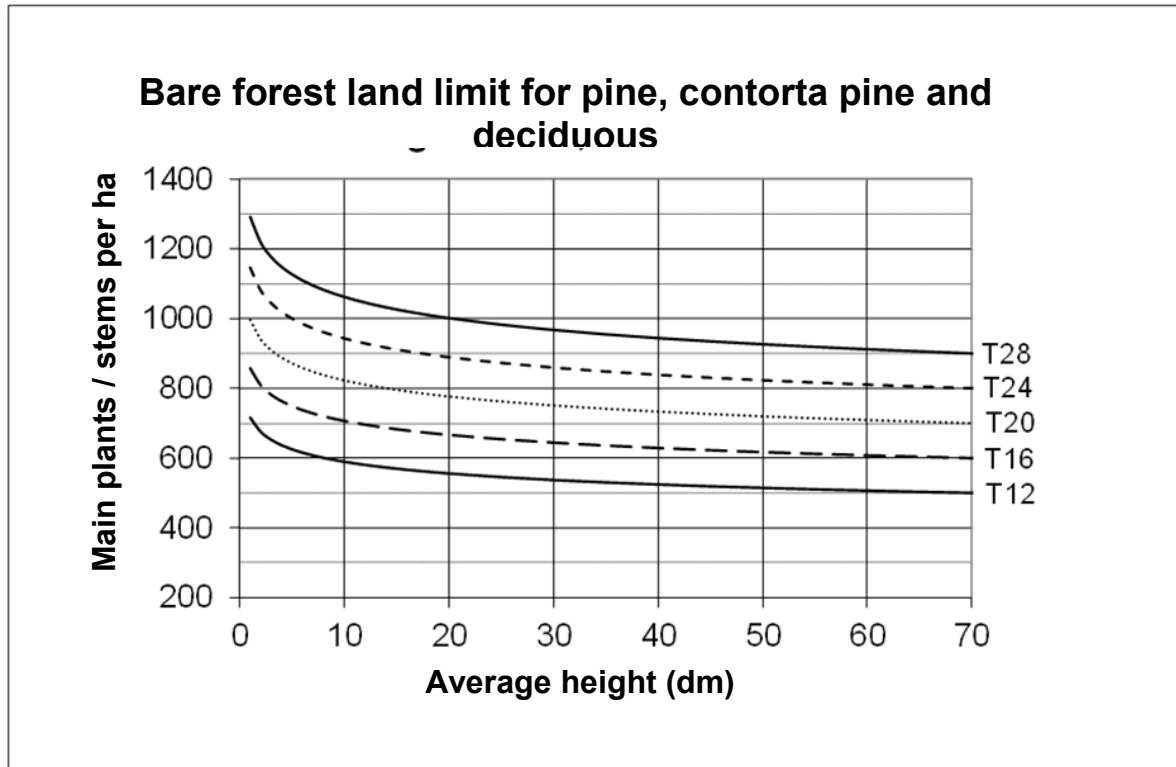

Fig. 6.1 Diagram for decision on bare forestland (Medelhöjd = Stand height, Huvudplantor / stammar = Main stems) for Tall = Pine, Ädellöv = Oak, Beech, Ash

**Bare forest land limit for pine, spruce, etc. tree species**

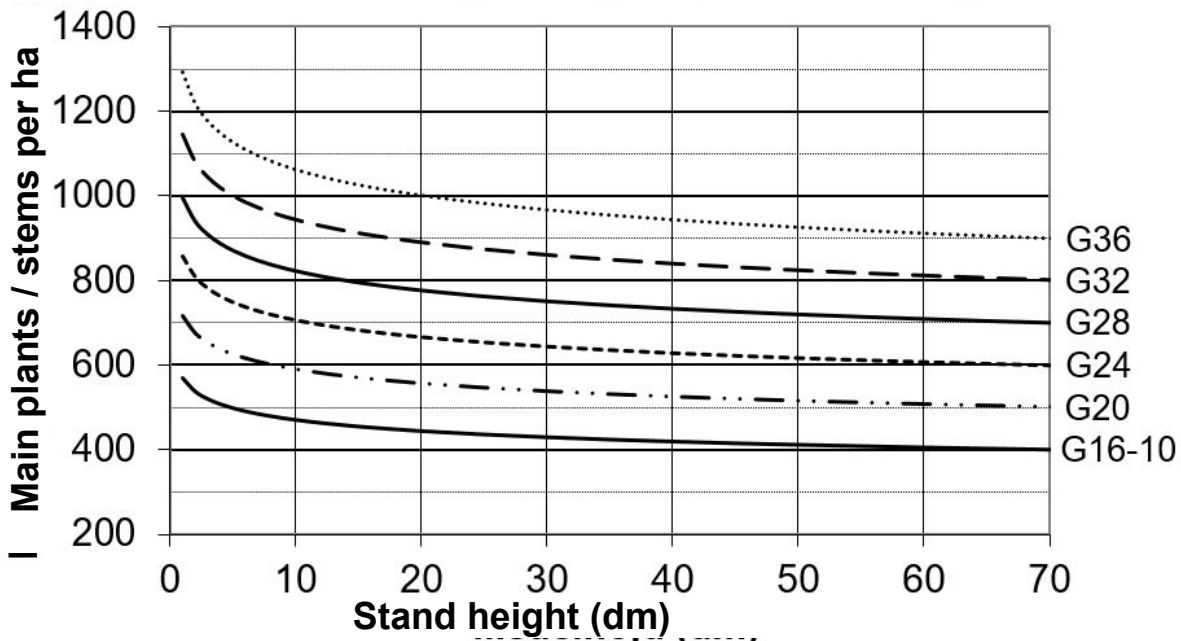

Fig. 6.2 Diagram for decision on bare forestland (Medelhöjd=Stand height, Huvudplantor/stammar=Main stems) for Gran=Spruce and other tree species.

### Thicket stage and young forest (B)

Thicket stage or young forest where more than half of the dominant and co-dominant trees are smaller than 10 cm at breast height. Three classes are distinguished:

- 21** *Thicket stage forest with average height below 1.3 m (B1)*
- 22** *Young forest with an average height between 1.3 and 3 m (B2)*
- 23** *Young forest with average height over 3 m (B3)*

The average height is the arithmetic average height of the main plants/stems after an imaginary possible cleaning. Definition main plant/stem, see page 6.38.

### Middle-aged forest and older thinning forest (C)

Middle-aged forest where most of the dominant and co-dominant trees are thicker than 10 cm at breast height. The age of the forest is lower than the minimum age allowed for final felling (rejuvenation felling) according to SVL. Forests older than the minimum age for final felling are also included in maturity class C if the next action is thinning. In doing so, however, the barring rules that exist regarding the proposed thinning action must be taken into account (see later in this section).

The minimum permissible age of a stand for final felling is determined by SI and the proportion and species composition of deciduous trees. Age refers to total, surface-weighted average age. The minimum permissible age for SI values outside the values given in a table is obtained by interpolating or extrapolating adjacent values.

The percentage in the tables indicates the share of the timber stock.

| <b>Leaves &gt; 50%</b> | <b>Of which &gt; 50%</b>         |                               |                             | <b><i>Fraxinus excelsior</i>,<br/><i>Fagus sylvatica</i> or<br/><i>Quercus robur</i> have<br/>individually ≤ 50%</b> |
|------------------------|----------------------------------|-------------------------------|-----------------------------|--|
|                        | <b><i>Fraxinus excelsior</i></b> | <b><i>Fagus sylvatica</i></b> | <b><i>Quercus robur</i></b> |  |
| <b>Age</b>             | 50                               | 80                            | 90                          | 35   |

In stands where conifers other than pine (*Pinus silvestris*) and/or spruce (*Picea abies*) represent > 50%.

| <b>Other conifers &gt; 50%</b> | <b>Site index, H 100</b>  |                       |                         |
|--------------------------------|---------------------------|-----------------------|-------------------------|
|                                | <b>&gt; G24, &gt; T24</b> | <b>G16-24, T16-24</b> | <b>&lt;G16, &lt;T16</b> |
| <b>Age</b>                     | 40                        | 45                    | 50                      |

In stands where the proportion of conifers in the timber stock is > 50% and conifers other than pine (*Pinus silvestris*) and/or spruce (*Picea abies*) represent ≤ 50%. The minimum permitted final felling age is determined by the tree species whose timber stock is largest. In the case of an equal share, the tree species indicating the site productivity applies.

| <b>Conifers &gt; 50% and<br/>Other conifers ≤ 50%</b> | <b>Site index, H 100</b> |            |                    |                    |                    |                    |                    |
|---|--------------------------|------------|--------------------|--------------------|--------------------|--------------------|--------------------|
|   | <b>G36</b>               | <b>G32</b> | <b>G28<br/>T28</b> | <b>G24<br/>T24</b> | <b>G20<br/>T20</b> | <b>G16<br/>T16</b> | <b>G12<br/>T12</b> |
| <b><i>Spruce dominates</i></b>                        |                          |            |                    |                    |                    |                    |                    |
| <b><i>Pine dominates</i></b>                          |                          |            |                    |                    |                    |                    |                    |
| <b>Age, D-county 1-8</b>                              |                          |            | 65                 | 70                 | 80                 | 90                 | 100                |
| <b>Age, rest of Sweden</b>                            | 45                       | 50         | 60                 | 65                 | 70                 | 80                 | 90                 |

Higher age than those in the tables above, means that the maturity class is D.

Within maturity class C, the following actual maturity classes are distinguished:

**31** *Unthinned forest where most of the dominant and co-dominant trees*

*are smaller than 20 cm at breast height (C1).*

- 32** *Thinned forest where most of the dominant and co-dominant trees are smaller than 20 cm at breast height (C2).*
- 33** *Forest younger than the minimum age allowed for final felling where the majority of dominant and co-dominant trees are thicker than 20 cm at breast height (C3).*
- 34** *Forests older than the minimum age for final felling that should be thinned at least once more (C4).*

Older forest (D)

Forests whose average age is higher than *the minimum age for final felling* and where the next action is final felling.

Within the maturity class D, two classes are distinguished:

- 41** *Older forest that has not reached the minimum recommended final felling age (D1).*
- 42** *Older forest that has reached the lowest recommended final felling age (D2).*

The minimum recommended age for a stand for final felling is determined by SI and deciduous tree proportion and species composition. Age refers to total, surface-weighted average age. The lowest recommended age for SI values outside the values given in a table is obtained by inter- or extrapolating adjacent values. The percentage in the tables indicates the share of the timber stock.

|                       |                          |               |                |
|-----------------------|--------------------------|---------------|----------------|
| <b>Oak I &gt; 50%</b> | <b>Site index, H 100</b> |               |                |
| <b>SI Spruce</b>      | <b>&gt; G31</b>          | <b>G28-31</b> | <b>&lt;G28</b> |
| <b>Age</b>            | 90                       | 100           | 110            |

|  |                          |               |               |                |
|--|--------------------------|---------------|---------------|----------------|
| <b>Deciduous trees &gt; 50%, oak ≤ 50%</b> | <b>Site index, H 100</b> |               |               |                |
| <b>SI Spruce</b>                           | <b>&gt; G35</b>          | <b>G33-35</b> | <b>G28-32</b> | <b>&lt;G28</b> |
| <b>Age</b>                                 | 85                       | 90            | 95            | 100            |

|  |                          |               |                |
|--|--------------------------|---------------|----------------|
| <b>Deciduous &gt; 50%,<br/>temperate ≤ 50%</b> | <b>Site index, H 100</b> |               |                |
| <b>SI Spruce</b>                               | <b>&gt; G27</b>          | <b>G24-27</b> | <b>&lt;G24</b> |
| <b>Age</b>                                     | 40                       | 45            | 55             |

Conifers other than pine (*Pinus silvestris*) and / or spruce (*Picea abies*) have > 50% of the timber stock.

|                                |                           |                       |                         |
|--------------------------------|---------------------------|-----------------------|-------------------------|
| <b>Other conifers &gt; 50%</b> | <b>Site index, H 100</b>  |                       |                         |
|                                | <b>&gt; G24, &gt; T24</b> | <b>G16-24, T16-24</b> | <b>&lt;G16, &lt;T16</b> |
| <b>Age</b>                     | 50                        | 60                    | 70                      |

In stands where the proportion of conifers in the timber stock > 50% and conifers other than pine (*Pinus silvestris*) and/or spruce (*Picea abies*) have ≤ 50%. The lowest recommended final felling age is determined by the tree species of pine or spruce whose timber stock is largest. In the case of an equal proportion, the tree species indicating the site productivity applies.

|   |   |          |           |          |           |          |           |          |           |          |           |          |           |          |
|---|---|----------|-----------|----------|-----------|----------|-----------|----------|-----------|----------|-----------|----------|-----------|----------|
| <b>Conifers &gt; 50%<br/>Other conifers ≤ 50%</b> | <b>Site index, H100 - Pine (T) and Spruce (G)</b> |          |           |          |           |          |           |          |           |          |           |          |           |          |
|   | <b>36</b>   |          | <b>32</b> |          | <b>28</b> |          | <b>24</b> |          | <b>20</b> |          | <b>16</b> |          | <b>12</b> |          |
| <b>D-county code</b>                              | <b>G</b>  | <b>G</b> | <b>T</b>  | <b>G</b> | <b>T</b>  | <b>G</b> | <b>T</b>  | <b>G</b> | <b>T</b>  | <b>G</b> | <b>T</b>  | <b>G</b> | <b>T</b>  | <b>G</b> |
| <b>1-6</b>  |   |          |           | 90       | 100       | 100      | 115       | 110      | 125       | 120      | 130       | 130      |           |          |
| <b>7-8</b>  |   |          |           | 85       | 95        | 90       | 110       | 100      | 120       | 110      | 130       | 125      |           |          |
| <b>9-12</b>                                       |   |          | 80        | 80       | 90        | 85       | 105       | 95       | 115       | 105      | 125       | 120      |           |          |
| <b>13-14</b>                                      | 65  | 70       | 80        | 80       | 90        | 85       | 100       | 95       | 110       | 105      | 120       | 120      |           |          |
| <b>15-19, 31</b>                                  | 65  | 70       | 80        | 80       | 90        | 85       | 100       | 90       | 110       | 100      | 120       | 120      |           |          |
| <b>20-26</b>                                      | 65  | 70       | 80        | 80       | 85        | 85       | 95        | 90       | 105       | 100      | 115       | 120      |           |          |
| <b>27-30</b>                                      | 65  | 65       | 80        | 75       | 85        | 80       | 90        | 85       | 100       | 100      | 115       | 120      |           |          |

### Multi-layered forest (E)

For multi-layered forest, there is only one class; 51 (E1). A multi-layered forest is characterized by the presence of trees in all stages of development. Tree groups often occur in different stages of development. The stand should normally be fully layered (see section 5.3). The forest is felled by multi-layering (selective felling) where trees that have reached felling age are cut down. Furthermore, trees in younger tree groups are thinned out to promote dimensional development. Furthermore, it should be clear from previous felling that the stand has been multi-layered.



## STAND AREA

The stand

The term stand is defined in section 2.7. The area is determined primarily by observations in the terrain and with the help of a map. For sample plots in maturity class *A1* and *B1*, the scale on the left in the table below is applied. For sample plots in other maturity classes, the scale on the right is applied.

Area (ha) of the described stand:

| maturity class<br>A1 and B1 |                  | maturity class<br>Others (B2-E1) |                 |
|-----------------------------|------------------|----------------------------------|-----------------|
| Code                        | Area class       | Code                             | Area class      |
| 5                           | 0.02 - 0.10      | 5                                | 0.02 - 0.10     |
| 18                          | 0.11 - 0.25      | 18                               | 0.11 - 0.25     |
| 38                          | 0.26 - 0.50      | 38                               | 0.26 - 0.50     |
| 80                          | 0.51 - 1.0       | 80                               | 0.51 - 1.0      |
| 150                         | 1.1 - 2.0        | 2000                             | Larger than 1.0 |
| 300                         | 2.1 - 4.0        |                                  |                 |
| 500                         | 4.1 - 6.0        |                                  |                 |
| 800                         | 6.1 - 10.0       |                                  |                 |
| 1500                        | 10.1 - 20.0      |                                  |                 |
| 2500                        | Larger than 20.0 |                                  |                 |

## RETENTION?

The stand

Is the described stand a remnant of an area that was planned for felling, but which was left as consideration in connection with final felling?

Codes

|   |     |
|---|-----|
| 0 | No  |
| 1 | Yes |

Conservation considerations in connection with final felling began to be introduced to a greater extent around 1990. The consideration is often left as a zone adjacent to the impediment or water, or as more or less small stand residues in or at the edge of the remedied area. Zones with a maximum width of 50 m are classified as consideration. Stands with a "rational" form for continued conventional forestry > 1.0 ha, are only classified in exceptional cases as consideration.

Islands of productive forest land, clearly surrounded by morass that has not been felled within a remedied area, are only classified as consideration in exceptional cases.

The degree of development of the stand was both at the time of felling and now D1 or D2. In the classification, any property boundaries are taken into account.

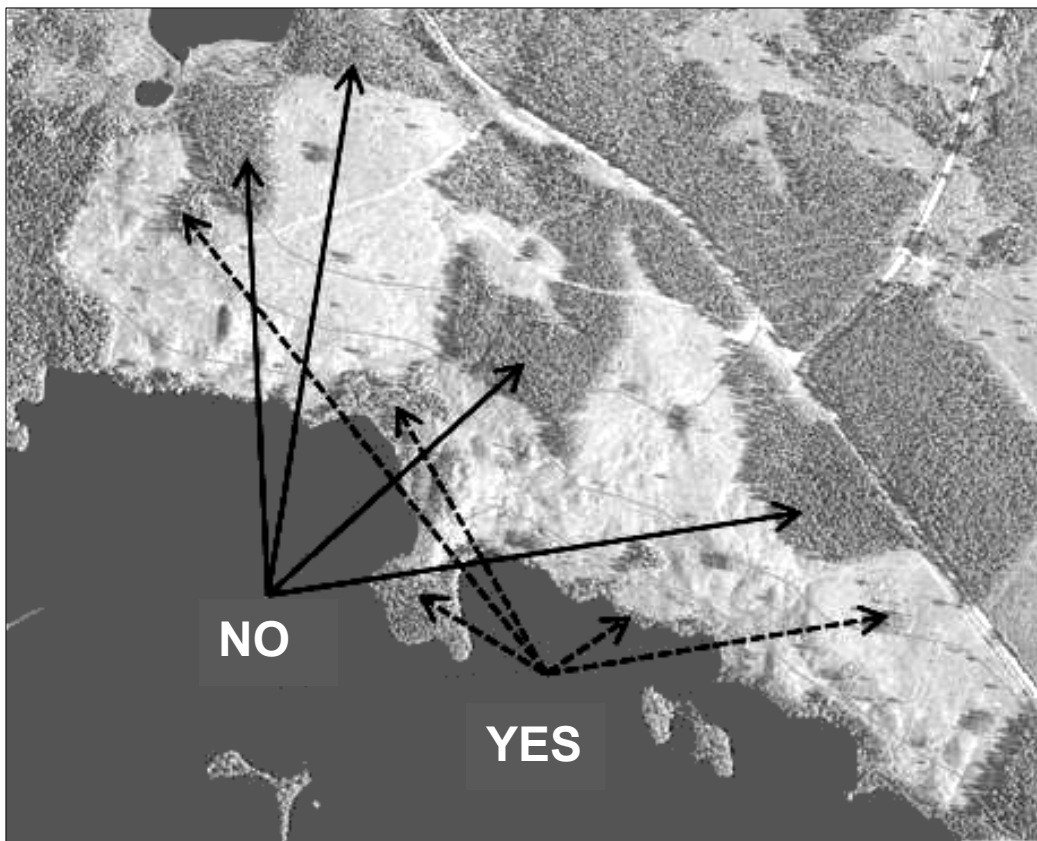

**Fig. 6.3** Example (No = No retention area, Yes = retention area)

## TYPE OF CONSIDERATION

The stand

Main character of the area left for nature conservation reasons

Codes

- 1 Edge zone next to morass
- 2 Edge zone next to rock
- 3 Edge zone next to water
- 4 Edge zone next to another, e.g. against fields or other stands
- 5 Small stand within remedied area (consideration stand)

## DATE OF CONSIDERATION

The stand

Code Date when the stand was excluded from final felling

- |   |                        |   |                       |
|---|------------------------|---|-----------------------|
| 0 | <i>This season</i>     | 6 | <i>Season 6-10</i>    |
| 2 | <i>Previous season</i> | 7 | <i>Season 11-25</i>   |
| 4 | <i>Season 2</i>        | 8 | <i>Season &gt; 25</i> |
| 5 | <i>Season 3-5</i>      |   |                       |

If final felling has been carried out next to the stand on several occasions, state the most recent felling occasion.

## MEDELHÖJD

20 m surface

Stand height (dm)

Codes: 0-500

The average height is determined either as the *basal area-weighted* average height or as the *arithmetic* average height.

If the basal area-weighted average height of the tree stand on the 20 m surface is 70 dm or higher, the average height is determined as the *basal*

*area weighted* average height. This excludes over storey trees, seed trees, undergrowth and dead trees.

For stands where the basal area weighted average height according to the above is lower than 70 dm, the average height is determined as the *arithmetic* average height for main stems or main plants after an intended possible cleaning. If there are several layers that are to be remedied in different ways, the average height is stated as above for the layer that determines the maturity class.

Appendix B1 describes how the height measurement is to be performed. The height is entered in the nearest whole decimetre.

## **BASAL AREA OF THE STAND**

20 m surface

basal area (m<sup>2</sup> per ha)

Codes: 0-99

The basal area *of the stand* is stated for stands where the average height is 70 dm or higher. The determination is based on relascope measurement and information on the basal area measured with caliper (see below). The basal area of the stand includes all trees except over storey trees, undergrowth and dead trees. When measuring the relascope measurement, note the different tree species' proportions of the basal area. Make sure that the estimate only refers to the action unit alt. part of the action unit in which the sample plot/sub-sample plot is located. The basal area is stated with two figures to the nearest whole m<sup>2</sup> per ha.

### **Basal area measured with caliper**

Basal area measured with caliper (m<sup>2</sup>/ha) is calculated automatically by the field computer. The information on the enclosed basal area is used as support only on undivided sample plots, disregarding the basal area for any over storey trees and undergrowth. For split surfaces, the basal area is set only with the guidance of relascope measurement.

## **Relascope measurement**

Relascope measurement of the basal area of the stand means counting of all trees except over storey trees, undergrowth and dead trees, whose diameter at breast height from the observation point is visible larger than the relascope's opening. Borderline cases (the diameter is as large as the opening of the relascope) are counted as half a tree. The number of trees included multiplied by the count factor is equal to the basal area expressed in m<sup>2</sup> per hectare.

**LIKÅLDR**

20 m surface

| Code | Age equality            |
|------|-------------------------|
| 0    | <i>Not the same age</i> |
| 2    | <i>Fairly equal age</i> |
| 3    | <i>Equal age</i>        |

A stand is considered to be of fairly equal age if at least 80% of the volume is within an age range of 20 years and of equal age if 95% of the volume is within an age range of 5 years. Other stands are classified as of different ages. In the case of multi-layered stands, this refers to the layer determining the maturity class.

**BESTÅNDSÅLDER**

20 m surface

Stand age (years)

Codes: 1-500

The average age of the stand is stated as total age. The total age of a tree means the number of years that have elapsed from the time the seed germinated up to and including the year before the estimate. If the basal area -weighted average height of the tree stand on the 20 m surface is 70 dm or higher, the age is determined as the basal area -weighted average age. On productive forest land, this excludes over storey trees, seed trees, undergrowth and dead trees.

For stands where the basal area-weighted average height is lower than 70 dm, the age is determined as the arithmetic average age. The assessment refers to the arithmetic average age of main stems or main plants after an imaginary possible cleaning.

In multilayer stands, the average age is stated as above for the layer determining the maturity class.

In young conifer stands, the age is determined by counting annual shoots from the ground and adding 2-3 years for plant age. In slightly older stands, the age can be determined by counting the number of annual shoots above breast height and adding the number of years it takes to reach breast height according to the table and instructions below.

When the stand is older and the shoots are difficult to see, the age is determined by boring and counting the number of annual rings at breast height. In addition, the time to breast height is added as below. To determine the age, on productive forest land, at least two trees are bored on each sample plot/sub-sample plot, the diameter of which is deemed to correspond to the average surface-weighted average diameter. If the age difference is greater than 10 years, another tree is bored. On permanent plots, the bored trees are taken outside the 10 m surface and the bored trees are registered in the menu bored trees. On temporary sample plots, the ordinary sub-sample trees can often be used for age determination. At boring and annual shoot count, the current year's annual ring and top shoot are not included.

If the closeness is at least 0.1, the age must always be stated, even if it involves practical difficulties. Rot in all bore cores is therefore not a reason not to state the age.

#### Supplement to breast height age:

The total age of a tree is determined as breast height age increased by the number of years that are normally estimated to be needed for a freely grown plant at the site in question to reach breast height. The following table of "supplement to breast height age" is used as a guideline for conifers.

| D-county<br>code  | Raised site productivity class H100 - pine and<br>spruce |   |    |   |    |    |    |    |    |    |    |    |    |   |
|-------------------|--|---|----|---|----|----|----|----|----|----|----|----|----|---|
|                   | 36   |   | 32 |   | 28 |    | 24 |    | 20 |    | 16 |    | 12 |   |
|                   | G  | G | T  | G | T  | G  | T  | G  | T  | G  | T  | G  | T  | G |
| <b>1 - 6</b>      |  |   |    | 9 | 11 | 11 | 13 | 13 | 17 | 17 | 22 | 25 |    |   |
| <b>7 - 13, 31</b> |  |   |    | 9 | 9  | 11 | 11 | 13 | 15 | 17 | 19 | 25 |    |   |
| <b>14 - 25</b>    | 7  | 7 | 8  | 8 | 8  | 10 | 10 | 12 | 12 | 14 | 16 |    |    |   |
| <b>26 - 30</b>    | 7  | 7 | 8  | 8 | 8  | 9  | 9  | 10 | 11 | 11 | 12 |    |    |   |

For **deciduous trees**, the values for spruce are used.

For **birch, aspen, etc. other tree species**, the following values are used for the time from seed to breast height:

- Good soils, H100 spruce and pine at least 26 m: 5 years.
- Medium good soils, H100 spruce and pine 17-25 m: 7 years.
- Weak soils, H100 spruce and pine 16 m and lower: 10 years.

If the tree is derived from stump shoots, the specified times should be shortened.

### **BESTKAR**

20 m surface

Code Stand character

1 *Normal*

2 *Natural forest character*

3 *Plantation forest character*

**2** The following is required for an indication of *natural forest character*:



- Coarse (> 25 cm dbh) dead trees occur.
- No measures taken in the last 25 years.

At a lower degree of development than maturity class D2, the following is required:

- At least 50 m<sup>3</sup> dead wood/ha or an old (> 175 years) upper layer.

At a degree of development corresponding to maturity class D2, at least four of the following requirements must be met:

- Over story trees are present on the 20 m surface.
- Stand age older than 150 years.
- Stand of different ages.
- Large diameter spread.
- Two- or multi-layered stand.

**3** The following is required for an indication of *plantation forest character*:

- Structures (coarse dead wood (> 25 cm), over storey trees, etc.) from previous stands are completely missing.
- At least 9/10 of the tree species mixture when all trees are included consists of one tree species.
- Extreme equality of age, all stems belonging to the layer determining the maturity class within 10 years.
- The stand must be single-layered. However, a lower layer of stand rejuvenation with the same tree species as the main layer is accepted. The average height of the lower layer must not exceed 5 dm.

In addition, the trees should be lined up in an even production line, 500-3000 stems per hectare depending on age.

## **TREE SPECIES AND PROPORTION**

### **TREE SPECIES COMPOSITION**

20 m surface

The tree species composition is specified in a separate menu that becomes available, if a tree species mixture is to be specified, when the main menu for the stand description has been registered.

## TREE SPECIES

Tree species.

| Code | Tree species           | Code | Tree species                 |
|------|------------------------|------|------------------------------|
| 1    | <i>Pine</i>            | 6    | <i>Fagus sylvatica</i>       |
| 2    | <i>Spruce</i>          | 7    | <i>Other deciduous trees</i> |
| 3    | <i>Birch</i>           | 8    | <i>Contorta pine</i>         |
| 4    | <i>Populus tremula</i> | 9    | <i>Other deciduous trees</i> |
| 5    | <i>Quercus robur</i>   |      |                              |

Pine also includes *Larix decidua* and other pines other than *Pinus silvestris*, but not contorta pine.

Spruce includes all *picea* and *abies* species, *Pseudotsuga menziesii* and foreign spruces and *Taxus baccata*.

Other deciduous trees includes *Alnus glutinosa*, *Alnus incana*, *Acer pseudoplatanus*, *Salix caprea* and *Sorbus aucuparia* thicker than 2 cm, *Sorbus intermedi* and other deciduous trees.

## PROPORTION

Proportion for each tree species (tenths)

Codes: 1-10

If the average height is determined as the basal area -weighted average height, the tree species composition is specified as tenths of the basal area . This excludes over storey trees, seed trees, undergrowth and dead trees. On other land use classes, all trees except dead trees are included.

If the average height has been determined as the arithmetic average height, the tree species composition is stated as tenths of the number of main stems or main plants after an imaginary possible cleaning.

In multi-layered stands, tree species composition is stated according to the above for the layer that determines the maturity class.

A tree type code can be entered only once.

## **PROPOSED ACTION and TIME PERIOD**

The stand

Proposed actions include both proposals for appropriate actions and the time period when the actions should be implemented. Below is a more detailed description of the various proposed actions. Proposed actions are registered in a separate menu that becomes available, if proposed actions are to be specified, when the main menu for the stand description has been registered.

## **ÅTGÄRD**

| Code | Proposed action   |
|------|---|
| 20   | Thinning. <i>May be stated as maturity class B3 and C.</i>                    |
| 30   | <i>Cleaning. May be stated as maturity class B and C1.</i>                    |
| 41   | <i>Cleaning of final felled area May be stated only as maturity class A.</i>  |
| 44   | <i>Felling of seed trees. May be stated as maturity class A and B.</i>        |
| 45   | <i>Felling of other layers. May be stated in maturity class A, B and C1.</i>  |
| 50   | <i>Soil preparation. May be stated only as maturity class A.</i>              |
| 70   | <i>Forestry (planting or sowing). May be stated only as maturity class A.</i> |
| 73   | <i>Auxiliary planting. May be stated in maturity class A, B1 and B2.</i>      |
| 81   | <i>Grass cleaning. May be stated in maturity class A, and B1.</i>             |

- *Note that you may enter more than one action, but not more than five. However, only one of the proposed forestry, cleaning and thinning actions may be specified. In addition, one and the same action may be specified only once. If no action is suitable or if the need for action cannot be determined, select "No action proposed" when the menu opens.*
- *Please note that "final felling" does not exist as a proposed action. Therefore, no proposed action should be set in maturity class D1 and D2. Proposed measures are also not set in maturity class E1.*

## **FTID**

Code Time period for proposed action

- 1 *The action should be performed immediately. Note that the code "1" should not be used for actions that can no longer be performed due to tardiness. Such actions are not addressed in the action proposal.*
- 5 *The action should be carried out within the next 5 years. It should not be performed immediately.*
- 10 *The action should be carried out within years 6-10 onwards. The time period is applied only for thinning.*

The proposal only covers measures that should be implemented within the next five-year period. For thinning, however, the assessment is made for a ten-year period.

The various proposed actions are commented on below.

## **KRONTÄCKN**

20 m surface

Canopy cover (%)

Codes: 0-100

Canopy cover refers to the proportion of the ground surface that is covered by tree canopies. The indication refers to diffuse cover (see Appendix B8). The variable is given by subjective assessment. The delimitation of the periphery within which a certain tree canopy is considered to completely cover the ground is estimated by first projecting the widest parts of a tree's canopy to one and the same level. Then one imagines a wide band resting against the tree canopy, as if it was sucked in towards the centre of the tree. The imagined position of the band constitutes the periphery of the canopy.

When assessing canopy cover, only living trees are included. Parts of trees that are covered by other trees are ignored. Canopy cover is specified regardless of average height and all trees, regardless of height, are included in the assessment. Shrubs are not included.

When specifying canopy cover, it is important that intuitively even classes (5, 10, 15, 20, 25, etc.) are not overrepresented in the material, as indications of such proximity make subsequent analyses difficult.

Class 0 means that canopy cover is lacking.

### **ANTAL HÄ+MEDHÄ**

20 m surface

Number of dominant and co-dominant trees per ha (100s)

Codes: 0-16

The *number of dominant and co-dominant trees per hectare* is registered in maturity classes C, D and E. Registration is made to the nearest hundred. Ex: 1,575 trees are registered with the code "16". The assessment of the number should be based on a count of dominant and co-dominant trees on a number of support surfaces with a radius of 3.5 m (the 3.5 m bar is used), normally five. The relationship between the number of stems on a 3.5 m surface and the stem count/ha is shown in diagrams later under the variable **CLOSENESS**.

### **ANTAL MPL**

20 m surface

Number of main plants/stems per ha (100s)

Codes: 0-35

The *number of main plants per ha* is registered in maturity class *A1 and B1* and the *number of main stems per ha* in maturity class *B2 and B3*. Registration is to the nearest hundred. Ex: 1,875 mpl are registered with the code "19". Below, *main plants/main stems* are referred to as *mpl*.

The average height of the maturity class determining layer for the 20 m surface is assessed, and on the basis of this and the SIS, the number of stems required to obtain a closeness unit 1.0 is determined. The relationship between the number of stems on a 3.5 m surface and the stem count/ha is shown in diagrams below under the variable **CLOSENESS**. The main plant/stem refers to a tree that belongs to a maturity class-determining layer and that must remain after an intended or completed cleaning down to a closeness unit of no more than 1.0.

The number of mpl per ha for the sample plot is determined by assessing the number of mpl on a number of support surfaces with a radius of 3.5 m (the 3.5 m bar is used), normally five surfaces. When calculating the number of mpl on the support surfaces, the relevant tree spacing and the plants/stems that are outside 3.5 m and that influence the choice within the surface must be taken into account.

The choice of mpl is made so that the height difference in the described stand is as small as possible. The choice of plants/stems should give as high and even a canopy ceiling as possible.

Trees whose tree class in the previous stand was dominant, co-dominant or dominated shall not be counted as mpl.

On bare forest land, the main plant may have a maximum height of 3 dm. In any denser areas (closed unit > 0.4) within the bare forest land soil, the assessment is made in the same way as in maturity class B1.

In maturity class B1, main plants must belong to the plant layer, i.e. a main plant must not be more than 2 m higher than the average height of the 20 m surface. Approved main plants are cultivated plants, as well as stand- and self-rejuvenated plants of suitable tree species and which are at least 1 dm high and at least 2 years old. Within the stand, areas with a degree of development corresponding to B2 or B3 may exist, in which case main stems are selected in the same way as in maturity class B2 and B3.

In maturity class B2 and B3, main stems must have a height of at least 0.25 x the average height of the eight highest coniferous stems (leaves are selected in the absence of conifers) within the 20 m surface (they must not be clearly overgrown). Clearly overgrown trees, i.e. trees whose height exceeds the double average height of the stand-forming layer for the 20 m surface, are always considered the least suitable when choosing between candidates for appointing the main stem, see order of priority below.

In maturity class B2 and B3, all tree species are approved as the main stem.

Damage never disqualifies a plant/stem as mpl, but some damage means that it is given lower priority in the choice between potential mpl, see below.

An undamaged plant/stem should be above 3 dms in height:

- have a continuous stem
- not be multi-stemmed
- the shoots of the uppermost canopy, grown in seasons 1 and 2, must not be completely grazed or dead
- not have stem fractures below the shoots of the last two seasons
- not have bark gnawing > 1/5 of the circumference
- not have an angle > 10 cm
- not have long bends caused by planting damage
- be free from a large number of damage which together result in low vitality.

The suitability of the tree species is defined in Appendix B9. When choosing between potential main plants, choose in order of priority 1-6 below. When choosing between potential main stems, choose in order of priority 1-12:

1. "Cultivated plant" without damage
2. "Suitable coniferous species" without damage
3. "Cultivated plant" with damage
4. "Suitable coniferous species" with damage
5. "Suitable deciduous tree species" without damage
6. "Suitable deciduous tree species" with damage
7. "Slightly unsuitable tree species" without damage (main stem only)
8. "Slightly unsuitable tree species" with damage (main stem only)
9. "Unsuitable" tree species without damage (main stem only)
10. "Inappropriate tree species" with damage (main stem only)
11. "Clearly overgrown", definition see above, without damage  
(only main stem)
12. "Clearly overgrown", definition see above, with damage  
(only main stem)

## **STAND DENSITY**

20 m surface

Calculated by the S&M system

Closeness

Codes: Average height 1 - 69 0-10

Average height  $\geq$  70 0-11

When the average height is determined as the arithmetic average height, the *closeness* is determined as h-closeness based on the current number of main stems/plants per ha and the number required for closeness 1.0. In other cases, the closeness is determined as mass closeness based on stand height and basal area. In the assessment, over storey trees, seed trees, undergrowth and dead trees are ignored. In multilayer stands, closeness refers to the maturity class determining layer. The closeness is coded "00" - "11", where "00" corresponds to closeness class 0.0, "01" to 0.1 etc. and "11" to a closeness higher than 1.0.

The H-closeness indicates the extent to which the existing number of main plants/stems is sufficient to utilize the soil's production capacity with the



current tree species composition in the long term - at approx. 7 m stand height. If the number of trees is considered sufficient to fully utilize the soil's production capacity, the h-closeness is set to 1.0. The figure on the next spread shows the number of main plants/stems evenly distributed over the 20 m surface, which is required for h-closeness 1.0 on different site productivity grades, for pine and spruce at different stand heights. Dominant tree species determine which chart to use. If the main plants/stems are mostly pine, *Quercus robur*, *Fagus sylvatica* or other deciduous trees, the pine curves are used, otherwise the spruce curves.

The H-closeness is calculated as the ratio between the current number of main plants/stems and the number at full closeness. The closeness is set after a fictitious cleaning where the aim is to achieve a closeness of 1.0 after cleaning. This means that the H-closeness can never be set higher than 1.0.

The definition of main plant/main stem is found above under the variable **NUMBER OF MPL.**

## REQUIREMENTS FOR H-CLOSENESS 1.0

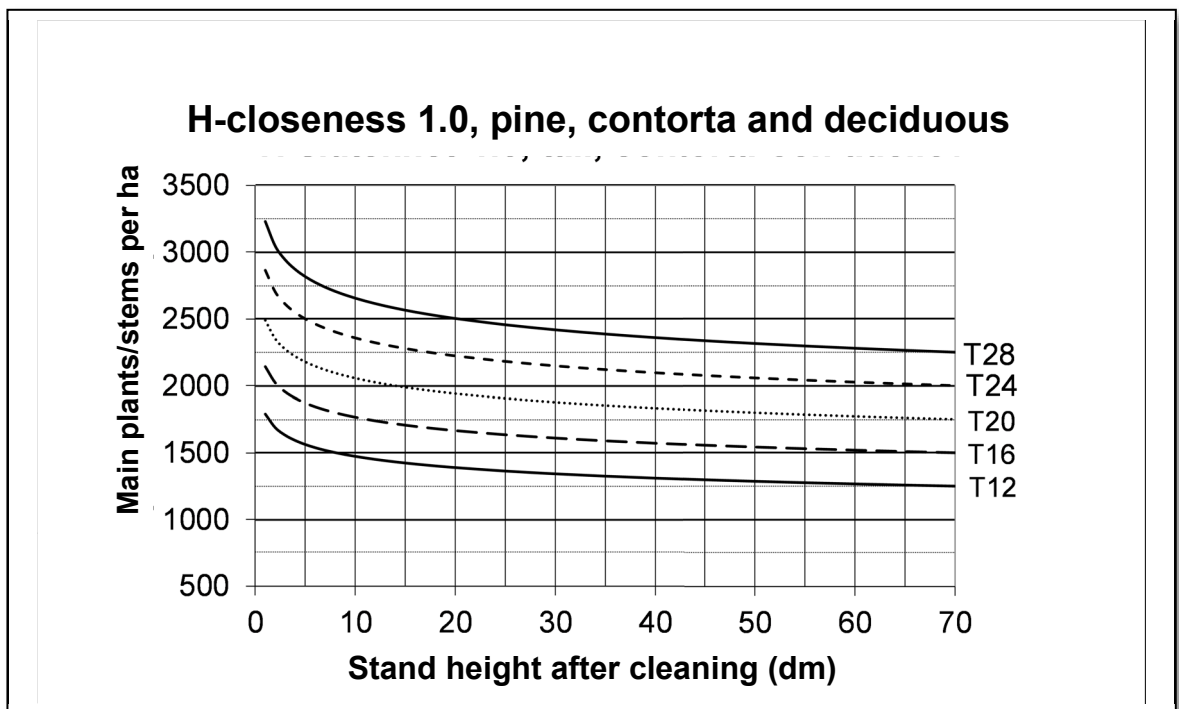
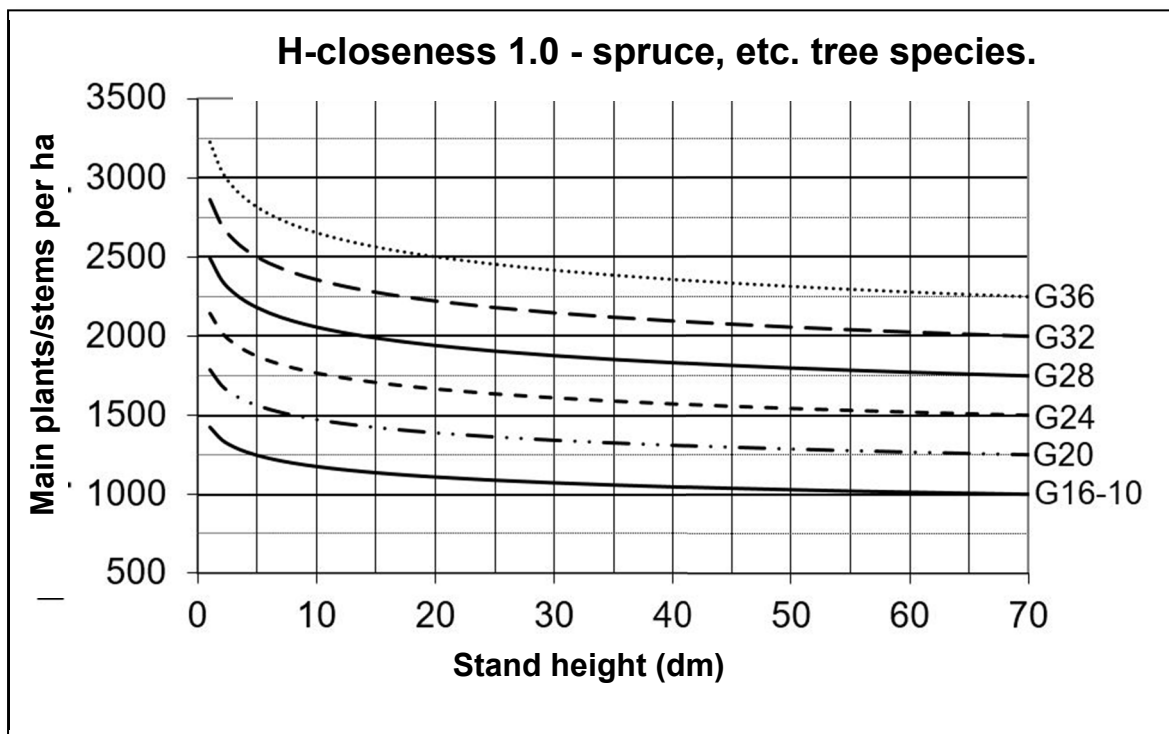

Fig. 6.5 Requirements for H-closeness 1.0 - pine, contorta and deciduous.



**Fig. 6.6** Requirements for H-closeness 1.0 - spruce, etc. tree species.

The above diagram ends at an average height of 70 dm. The requirement for the number of main stems for heights above 70 dm is the same as for 70 dm. The mass closeness is assessed on the 20 m surface according to the diagram on the next page. Conifer-dominated stands are then corrected, depending on the site index, in accordance with the table below.

## GAPS

20 m surface

The side of the gap square is calculated by the S&M system

Code Looseness

0 *Not loose stand. Within the 20 m surface there is (the surface is touched by)*

*a maximum of 1 gap. Stands with closeness  $\leq 0.2$  are also included here.*

1 *Somewhat loose stand. Within the 20 m surface there are (the surface is touched by) 2-3 gaps.*

2 *Loose stand. Within the 20 m surface there are (the surface is touched by) at least 4 gaps.*

Looseness indicates, together with the stem count and basal area, the extent to which the existing stand utilizes the soil's production capacity. A gap is defined as follows:

Average height lower than 30 dm:

An area without main plants/stems within which is a square whose side length is at least 2 times the average distance between the main plants (tree spacing), however at least 5 m. Ex: In a rejuvenation with 1,500 seedlings/ha, the average tree spacing is 2.6 m. A gap must therefore be at least 5.2 x 5.2 m. The diagram below shows the relationship between the stem count per ha and the side of the gap square.

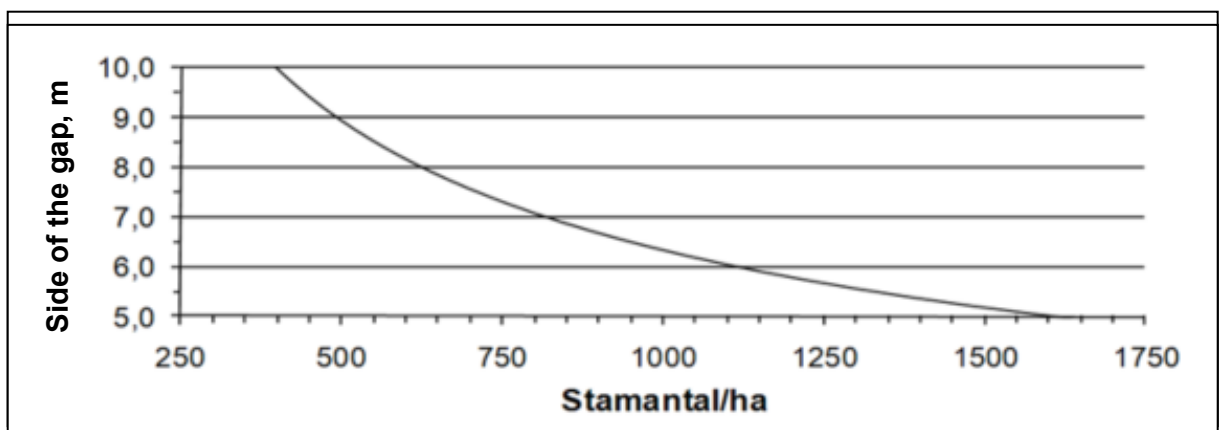

**Fig. 6.8** The relationship between the stem count and the side of the gap

Average height 30 dm and higher:

An area without conceivable main stems (average height 30-69 dm) or without *dominant* or *co-dominant trees* (average height  $\geq 70$  dm), within which a square with the smallest side length can be found as below. Minimum gap size 5x5 m and maximum 10x10 m.

The size of the gap square is determined when the average height is 30 dm or higher based on either average height or tree spacing. The one of the two approaches that gives the greatest value on the side of the square should be used. When determining with reference to the tree spacing, the side of the gap square is calculated as double the tree spacing, i.e. in the same way as for stands with an average height  $<30$  dm. Note that the tree spacing should be counted including forest roads and any gaps. When calculating the tree spacing, it is usually easiest to start from the number of stems per hectare. The relationship between square tree spacing and number of stems per hectare is shown in the previously reported help table in connection with the variable Closeness. The diagram below shows the relationship between the number of stems per hectare and the side of the gap square directly.

Vid bestämning av luckkvadratens sida med ledning av medelhöjden gäller att sidan beräknas som  **$0.2 \times \text{medelhöjden} + 2 \text{ m}$** .

When determining the side of the gap square based on the average height, the side is calculated as  **$0.2 \times \text{the average height} + 2 \text{ m}$** .

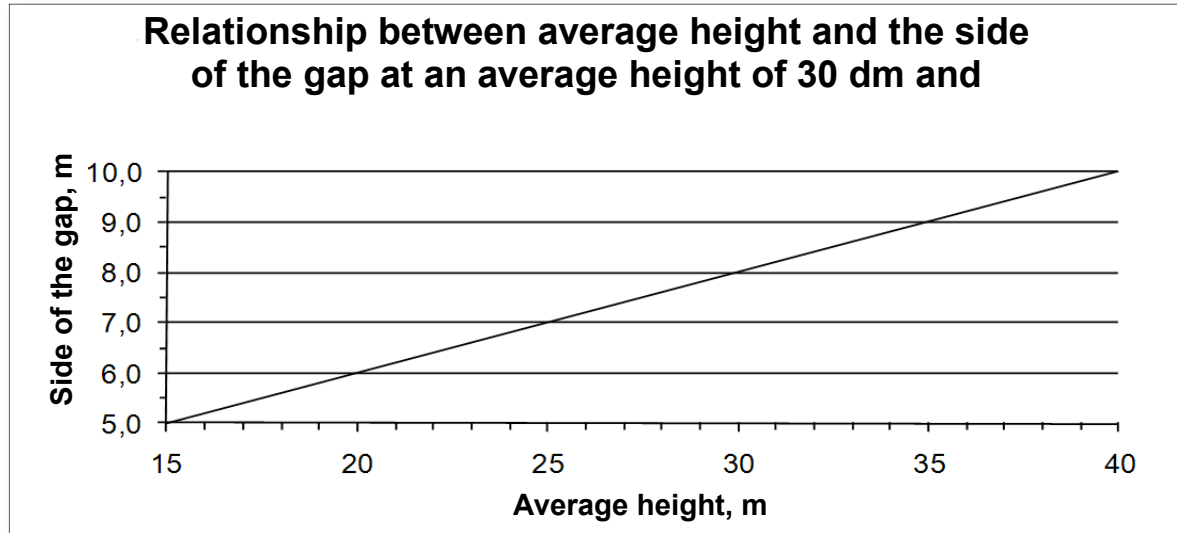

**Fig. 6.9** Relationship between average height and the side of the gap at an average height of 30 dm and higher

## 6.5 INTERNATIONAL LAND USE CLASSES

International land use classes must be registered for sub-sample plots with the traditional land use classes *morass (04)*, *rock and certain other impediments (05)*, *subalpine coniferous woodland (06)* and *high mountain (07)*. For other land use classes, classification takes place afterwards based on traditional land use classes. Definitions and codes are given below.

### LAND USE CLASS (FAO)

20 m surface

| Code | International land use class    |
|------|---------------------------------|
| 1    | <b><i>Forest</i></b>            |
| 2    | <b><i>Other wooded land</i></b> |
| 3    | <b><i>Bare impediment</i></b>   |

Determination of *international land use class* is based on current tree height and current canopy cover. In cases where the trees and/or shrubs have been affected by an acute temporary disturbance, e.g. fatal infestation by insects, the determination should be based on the potential height and canopy cover.

### **1 *Forest land***

Productive forest land and other tree-bearing land that bears forest with a height of at least 5 m and where the canopy cover for trees over 5 m is  $\geq 10\%$ .

### **2 *Other wooded land***

- a) Land which does not constitute forest land and which bears trees, which are at least 5 m and the canopy cover for trees over 5 m is  $\geq 5\%$  but  $<10\%$ .
- b) Land which does not constitute forest land and which bears trees and/or shrubs which are at least 0.5 m. The total canopy cover for trees and shrubs over 0.5 m is  $\geq 10\%$ .

### **3 *Bare impediment***

Impediment land that does not constitute forest land or tree and shrub land.

If there are several different types of international land use classes within the 20 m surface, or within the part of the 20 m surface that is taken into account in split sample plots, the dominating land use class is registered.

## **6.6 DAMAGE TO STANDS**

Stand damage is always assessed on the 20 m surface and includes the following three steps:

1. Assessment of the total degree of damage to the stems that

currently make up the stand, as well as the dominant cause of damage, regardless of when the damage occurred.

2. Assessment of the proportion of damage for individual causes of damage for the stems that are included and/or were included in the stand before the time of the damage, during the last five years.
3. Assessment of whether damage has occurred in the last five years to such an extent that the stand that existed before the time of the damage was spoiled.

In stands with an average height of 70 dm and higher, the assessment of damage refers only to trees in the tree classes *independent*, *dominant* and *co-dominant*. In stands with an average height of less than 70 dm, the assessment refers to *main plants* or *main stems*, i.e. the stems that are included in the assessment of closeness. When assessing the degree of damage, the stems referred to above, which currently constitute the stand and the proportion that are damaged, are assessed. When assessing damage within 5 years, or Reduced, the stems referred to above, which before the time of the damage constituted the stand and the proportion of these that were damaged or dead, are assessed in Damages within 5 years, or the stand is registered as Reduced if extensive damage resulted in a reduced maturity class. When reference is made below to “current tree classes”, this refers to both the above-mentioned tree classes and also main plants/stems. To help with the assessment, support surfaces can be laid out or frequency studies can be made along planting rows, if any.

The following types of damage are included:

|                       |
|-----------------------|
| <b>Root damage</b>    |
| <b>Cambial damage</b> |
| <b>Stem damage</b>    |
| <b>Canopy damage</b>  |

<sup>1</sup> In plant and young forests, for trees <40 mm, damage that includes



> 2/3 of the circumference is counted as damage. For trees > 40 mm, the damage must exceed 20 cm<sup>2</sup>.

### **SKAD LEV?**

Code Does the damage rate exceed 30% for living trees ?

0 No  
1 Yes

On bare forest land (maturity class "11") "No" is registered.

### **SKADEGR LEV**

Damage rate for living trees (%)

Codes: 31-100

The assessment refers to the proportion of living trees in existing stands that have a damage according to the above definition. In stands with an average height of 70 dm or higher, trees in the above-mentioned tree classes are included. Trees that belonged to these tree classes, but due to damage no longer do so, are also included if they are alive. In stands with an average height of less than 70 dm, only approved main plants/stems are included. Tree individuals that are no longer fit are not included in the described stand.

## DOM SKADORS

| Code | Dominant cause of damage to living stands. |   |
|------|--|---|
| 11   | <b>Climate</b>                             | <i>Wind and/or snow</i>                           |
| 12   |  | <i>Frost</i>                                      |
| 15   |  | <i>Other</i>                                      |
| 21   | <b>Human</b>                               | <i>Forestry</i>                                   |
| 22   |  | <i>Twisted roots or other<br/>planting damage</i> |
| 25   |  | <i>Other</i>                                      |
| 26   |  | <i>Human nature conservation</i>                  |
| 31   | <b>Vertebrate</b>                          | <i>Moose</i>                                      |
| 36   |  | <i>Reindeer</i>                                   |
| 37   |  | <i>Deer</i>                                       |
| 38   |  | <i>Wild boar</i>                                  |
| 32   |  | <i>Other larger mammals</i>                       |
| 33   |  | <i>Beaver</i>                                     |
| 34   |  | <i>Other rodents</i>                              |
| 35   |  | <i>Other vertebrates</i>                          |
| 41   | <b>Insect</b>                              | <i>Tomicus piniperda</i>                          |
| 42   |  | <i>Spruce bark beetle</i>                         |
| 43   |  | <i>Another bark beetle</i>                        |
| 44   |  | <i>Conifer- or leaf-eating insect</i>             |
| 46   |  | <i>Hylobius abietis</i>                           |
| 45   |  | <i>Another insect</i>                             |
| 51   | <b>Fungus</b>                              | <i>Cronartium flaccidum, Peridermium pini</i>     |
| 52   |  | <i>Rot fungus or Nectria galligena</i>            |
| 53   |  | <i>Gremmeniella</i>                               |
| 54   |  | <i>Lophodermium piceae</i>                        |
| 56   |  | <i>Uredinales</i>                                 |
| 57   |  | <i>Melampsora pinitorqu</i>                       |
| 55   |  | <i>Other fungus</i>                               |
| 71   | <b>Fire</b>                                | <i>Fire</i>                                       |
| 81   | <b>Reserve code</b>                        |   |
| 91   | <b>Other</b>                               | <i>Other reason without a code</i>                |

The dominant cause of damage is stated if the degree of damage exceeds 30%. Only damage in accordance with the types of damage initially defined are included.

### **SKAD INOM 5 ÅR?**

Code Damage within 5 years?

- 0 *No, no single cause of damage with damage percentage > 10%*  
1 *Yes, individual cause of damage with damage percentage > 10%*

Damage includes damage incurred during season 0-5 as well as damage of a continuous type, such as *Cronartium flaccidum*. The assessment is made for individual causes of damage. Damage must therefore be stated if the proportion of damaged trees for a certain cause of damage exceeds 10%. The damage proportion is calculated as the proportion damaged of all trees in the relevant tree classes, regardless of tree species.

The assessment includes all trees in the current tree classes, as well as trees that were damaged or died in season 0-5, if they belonged to these tree classes. Also included are trees that were previously main plants/stems but which are no longer fit due to damage or because they died during season 0-5. A maximum of three causes of damage can be specified. If the cause of damage cannot be determined, state "other". On *bare forest land* (maturity class "11") the code "0" is inserted).

Damage within five years are registered in a special menu "Stand damage within 5 years" which becomes available in the menu overview if you answered Yes to this variable.

### **SKADORS**

Cause of damage for damage within 5 years

Codes: *Same as for dominant damage cause above.*

### **SKADEANDEL**

Proportion of damaged stems within 5 years (%)

Codes: 11-100

The *damage proportion* (proportion damaged by the total number of trees in the relevant tree classes) is stated here for damage occurring in season 0-5 for the damage cause in question.

### **ANDEL NYA**

Proportion of injured stems season 0-1 (%)

Codes: 10-100

The damage proportion (proportion damaged by the total number of trees in the relevant tree classes) is stated here for damage occurring in season 0 or 1 for the damage cause in question. The proportion also includes trees that died during season 0-1 if they belonged to the relevant tree classes. For damage ratio 0-10, the code is set to "10" and no further registrations are made.

### **ANDEL DÖDA**

Percentage of dead stems season 0-1 (%)

Codes: 0-100

The total proportion of trees that died due to the damage cause in question (the proportion of deaths in relation to the total number of trees in the relevant tree classes) during season 0 or 1 is stated.

### **SKADETIDPUNKT**

| Code | Date of damage season 0-1               |
|------|---|
| 00   | <i>This season</i>                      |
| 01   | <i>Previous season</i>                  |
| 10   | <i>Both previous and current season</i> |

## NEDSATT?

| Code | Reduced maturity class? |
|------|-------------------------|
| 0    | No                      |
| 1    | Yes                     |

Reduced maturity class = *yes* refers to describing damage to the stand that existed before the damage occurred. The extent of the damage is such that the closeness of the former stand no longer exceeds the bare forest land boundary. For example, fire and windthrow can lead to such extensive damage. Note that the assessment is made for the 20 m surface. This means that the action unit does not otherwise have to be damaged. If a smaller part of an action unit is reduced, it is reduced if this smaller part meets the area requirement for the anomalous part (> 0.1 ha). If this is not met, it is reduced only if the action unit as a whole is considered reduced.

In the case of damage in the maturity classes B1-B3, use *Reduced maturity class = yes*, only in cases where the damage has resulted in the remaining live stems not exceeding the bare forest land limit. This means that e.g. extensive moose damage within 5 years, which did NOT give rise to bare forest land, must be registered by using "Damage within 5 years? = *yes*". In cases where the moose damage has given rise to bare forest land, only *Reduced maturity class = yes* is used to describe the damage.

Only damage incurred during season 0-5 are included.

If a stand is classified as reduced, this means that when registering the degree of damage to living tree stands and when registering damage within 5 years, only damage that applies to the "new" reduced stand is included. Damage to the original stand is thus not included.

## SKADORS NEDS

Cause of damage for reduced maturity class

Codes: *Same as for dominant damage cause above.*

## TID HUGGKLASS

Code Former maturity class

|    |    |    |    |    |    |
|----|----|----|----|----|----|
| 21 | B1 | 32 | C2 | 41 | D1 |
| 22 | B2 | 33 | C3 | 42 | D2 |
| 23 | B3 | 34 | C4 | 51 | E1 |
| 31 | C1 |    |    |    |    |

If a reduced degree of development is specified, the previous *degree of development* corresponding to the maturity class must also be stated. For a definition of the different maturity classes, see section 6.4.

## TID NEDS

Code Time of damage that led to the maturity class

|    |  |
|----|--|
| 00 | <i>This season</i>                             |
| 01 | <i>Previous season</i>                         |
| 05 | <i>Seasons 2-5</i>                             |
| 15 | <i>Several seasons including season 0 or 1</i> |

## 6.7 COMPLETED ACTIONS

The menu applies to *productive forest land, natural pastures, arable land, morass, rock and certain other impediments, subalpine coniferous woodland, high mountains, roads and railways, power lines and other land*. On the land use classes arable land, roads, power lines and other land, registration takes place only in connection with stump inventory when trees have been felled in season 1 and only miscellaneous felling can be specified.

In the menu, various forest actions that have affected the sample plot are registered. In addition to the action itself, the time of the action is registered as well as some other information linked to the action.

In volume plots, both permanent and temporary, all actions performed in the existing stand during the last 25 years are registered. Of actions carried out in a previous stand, all measures are registered within 5 years, as well as final felling, regardless of when it took place during the last 25 years.

On permanent sample plots, however, only measures that have not been registered before are registered, i.e. in the normal case actions carried out within the last five years. Previously registered actions are shown on the tree map.

Actions that cannot be determined with certainty are not registered. For example, soil scarification carried out more than 10 years ago can be difficult to ascertain.

On stump plots, only felling measures carried out in season 1 are registered.

For measures carried out on volume areas within the last five years, a more detailed description is made than for measures carried out more than five years ago. Only one action item for each type (code) of action may be registered. However, actions 22, 23, 31, 33 and 43 can be repeated if the date of the action differs.

On volume plots:

- On productive forest land, actions are registered as soon as they have been carried out in the stand on the 20 m surface, or have been included in the rejuvenation work for this. However, miscellaneous felling is only registered if trees are felled on the 10 m surface.
- On non-productive forest land, actions are registered as soon as they have been carried out on the 10 m surface.

On stump plots:

- On productive forest land, felling measures carried out in season 1 are registered as soon as they have been carried out in the stand on the 20 m surface. However, miscellaneous felling is only registered if trees are felled on the 7 m surface.
- On non-productive forest land, felling measures carried out in season 1 are registered as soon as stumps are found on the 7 m surface.

When felling in connection with decontamination of stand damage, recovered dead trees in the selected basal area are included in determining which type of felling is to be registered. Reprocessing of a windthrown final felled area (bare forest land) is classified as final felling.

If several different felling actions have been carried out at the same time, only the dominant felling is stated, for example when cleaning has been carried out in the same season as final felling.

If there is a clear limit for the measure within the 20 m surface, the action is only stated if the 10 m surface is within the part where the action was taken. Ditching is indicated if there is a ditch within 25 m from the sample centre within the action unit.

## **UÅTGÄRD**

20 m surface



### Final felling

Code Type of action

- 10 *Final felling performed season 6-25.*
- 11 *Final felling without stand regeneration or seed trees season 0-5.*
- 12 *Final felling without seed trees, with stand rejuvenation season. 0-5.*
- 13 *Final felling with leaving of seed trees season 0-5.*

Final felling refers to felling which means that the density of the layer that determines the maturity class, after felling, is below the limit for bare forest land (see under the variable maturity class in section 6.4). After final felling, however, there may be a remaining layer with a number of stems exceeding the bare forest land limit, which was previously undergrowth in the old stand, so-called stand rejuvenation or a seed tree stand may remain. Minimum requirements for seed tree stand are 15 suitable seed trees per ha.

### Thinning

Code Type of action

- 20 *Thinning performed season 6-25.*
- 21 *First thinning performed season 0-5.*
- 22 *Other thinning performed season 0-5.*
- 23 *Multi-layering performed season 0-5.*

Thinning refers to a sparse felling, in which the volume extracted predominantly originates from trees thicker than and equal to 10 cm at breast height. After felling, a stand remains denser than the limit for bare forest land (see under the variable maturity class in section 6.4). At least 10% of the basal area of the sparse stand before felling is removed. Multi-layering is a rare form of felling. Extraction usually takes place from above and the aim is to obtain a stand covering all ages and layers. Rejuvenation takes place gradually through stand rejuvenation

Cleaning

| Code | Type of action   |
|------|--|
| 30   | <i>Cleaning performed season 6-25.</i>   |
| 31   | <i>Stand-care cleaning carried out season 0-5. The action is performed in relatively young stands that have never been thinned. The purpose is to clear production stems, remove competing trees in all height layers, and transfer the growth to the released stems. Positioning of so-called frost screens is also included.</i> |
| 33   | <i>Precommercial thinning in older forest performed season 0-5. The measure is carried out in stands that will soon be thinned or felled. The purpose is to remove low and relatively small stems, so that future felling is facilitated and cheaper. Cleaning before final felling is also included here.</i>                     |

Cleaning refers to thinning of forests, where the majority of the volume extracted (excluding over storey trees, seed trees, etc.) originates from trees smaller than 10 cm at breast height.

Other types of felling

| Code | Type of action  |
|------|---|
| 40   | <i>Other felling (see definitions below) performed season 6-25.</i>   |
| 43   | <i>Miscellaneous felling performed season 0-5. Felling of individual windthrow, dead or damaged trees and other individual trees. Felling of this nature must not lower the basal area by more than 10% for an entire action unit. Stronger fellings are classified as cleaning, thinning or final felling.</i> |
| 44   | <i>Felling of seed trees carried out season 0-5. The number of seed trees must total at least 15 per ha. In case of lower numbers, the felling is classified as "miscellaneous felling".</i>  |
| 45   | <i>Felling of other layers performed season 0-5. This includes</i>  |

*felling of layer-forming over storey trees other than seed trees and decommissioning of so-called frost screens. Cleaning performed as a separate measure after final felling is also included here.*

- 46 *Stump removal performed season 0-5. Indicated only if it is considered that the stumps have been recovered or will be recovered to be used as a fibre raw material.*

## Tillage

- | Code | Type of action   |
|------|--|
| 50   | <i>Soil scarification carried out in years 6-25. On permanent surfaces, driving damage incurred in years 6-10 is also included.</i>  |
| 51   | <i>Patchy soil scarification carried out in years 0-5. Planting points with exposed mineral soil have been created in the form of patches, preferably with drawn devices. Either mineral soil laid on top of humus, or patches where humus has been removed.</i> |
| 52   | <i>Soil scarification in rows carried out in 0-5. Planting points with exposed mineral soil created in the form of rows. Either mineral soil laid on top of humus, or rows where humus has been removed.</i>   |
| 54   | <i>Raised soil scarification with excavator made in years 0-5. Patches of humus and mineral soil removed. Mineral soil laid in a pile on top of stripped humus next to the pit.</i>  |
| 56   | <i>Burning of a clear-felled area carried out in years 0-5. Fire intentionally used as a soil scarification method.</i>  |
| 57   | <i>Other fire in years 0-5.</i>  |
| 58   | <i>Burning, intentional or otherwise, years 6-25.</i>  |

Soil *scarification* refers to a measure that treats the top part of the soil

surface and which is carried out to facilitate rejuvenation. The purpose of the soil *scarification* is to eliminate competing vegetation for a period, and to create good conditions for establishing a new stand from seed or plant.

Code "50" includes all "mechanical" types of soil *scarification* , i.e. codes "51" - "54".

### Ditching

| Code | Type of action   |
|------|--|
| 60   | <i>Ditching performed years 6-25. This also includes cleaning of older ditches.</i>  |
| 61   | <i>Safety ditching in connection with final felling carried out in years 0-5. The protective ditches are included in productive forest land with a high groundwater level and made after final felling. The measure will temporarily drain the soil. Ditch depth <math>\leq 0.5</math> m and with flat ditch edges to avoid erosion.</i> |
| 62   | <i>Ditch cleaning performed in years 0-5. Action aimed at improving the function of existing ditches.</i>  |
| 63   | <i>Other trenching carried out in years 0-5. Classic soil drainage, which requires permission. Should persistently lower the groundwater level and is usually deeper than measure 61.</i>  |
| 69   | <i>Clogging of ditch years 0-5. Measure intended to impair the function of existing ditches. The measure is used in nature conservation.</i>   |

Safety ditches can be specified if final felling has been done within the last 10 years.

### Rejuvenation measures

| Code | Type of action   |
|------|--|
| 70   | <i>Planting carried out in years 6-25. Planting, sowing or</i> |

*supplementary planting.*

- 71 *Planting carried out in years 0-5. Planting carried out on bare forest land*
- 72 *Sowing performed in years 0-5. Sowing performed on bare forest land*
- 73 *Auxiliary planting carried out in years 0-5. Supplementary planting to raise the closeness. A supplementary planting on bare ground is called supplementary planting if the number of plants required to reach the bare ground limit is lower than the existing number of main plants, otherwise the measure is classified as planting.*

#### Other measures

Code Type of action

80 *Fenced.*

90 *Trunk pruning for quality-creating purposes.*

Stem pruning may only be specified if it was carried out when the stand was in maturity class B1 – C2 or E1.

#### **TIMING**

20 m surface

Time of action performed

*Current year or season*

*Year or season 3-5*

*Last year or season*

*Year or season 6-10*

*Year or season 2*

*Year or season 11-25*

The time for the action is stated in a slightly different way, depending on whether the measure is a form of felling or other measure. For felling measures, time is defined in terms of seasons where one season is the time from bud burst in a given year to bud burst next year. For other actions, the time is defined as a calendar year. The delimitation of different years and seasons is shown schematically below:

| 2018   | 2019 |   |   |   |   | 2020 |   |   |   |   | 2021 |   |   |   |   |   |   |   |   |   |
|--------|------|---|---|---|---|------|---|---|---|---|------|---|---|---|---|---|---|---|---|---|
|        | N    | D | J | F | M | A    | M | J | J | A | S    | O | N | D | J | F | M | A | M | J |
| Year   | 3    |   | 2 |   |   |      |   | 1 |   |   |      |   | 0 |   |   |   |   |   |   |   |
| Season | 3    |   | 2 |   |   |      |   | 1 |   |   |      |   | 0 |   |   |   |   |   |   |   |

**Fig. 6.12** Schematic figure of the delimitation of different years and seasons for the action performed.

→ *Distinguishing between seasons 0, 1 and 2 is primarily a matter of local experience. Therefore, always visit the so-called calibration areas at least twice a season. Information about the surfaces can be found in special map material.*

### **ODLTRSL**

20 m surface

Tree species in forestry .

Codes: 2-digit code according to Appendix B9.

För åtgärderna plantering, sådd och hjälpplantering säsong 0-5 ska även anges det trädslag som använts. Endast en art kan anges. Skulle flera förekomma registreras den mest förekommande.

For the actions planting, sowing and auxiliary planting season 0-5, the type of tree used must also be stated. Only one species can be specified. Should several occur, the most common is registered.

### **ORSAK AVV**

20 m surface

Code Reason for felling

1 *Normal felling*

2 *Remediation after damage*

3 *Nature and environmental conservation*

4 *Other*

For final felling, thinning and miscellaneous felling carried out within the last five years, an assessment of the reason why felling has taken place must also be made. If more than one felling has been done with the same code for the variable time, the assessment is made for the felling that has yielded the largest volume.

Normal felling refers to conventional felling measures during the rotation time of the stand.

Remediation after damage is specified if it is clear that special actions, which would not normally have been taken, have been taken to decontaminate the stand. Examples can be decontamination after fire, wind, bark beetle or *Gremmeniella* damage. Another example may be when a young stand is cleared due to an unwanted rejuvenation result or young forest condition.

Felling for *nature conservation* purposes is characterized by the fact that mainly deciduous trees are left and that large trees are released.

Other cause is stated in other cases, e.g. felling prior to the construction of a road or power line, sight clearing and cleaning around cultural relics.

**SKADEORS AVV**

20 m surface

## Code Damage causing felling

---

|    |                           |    |                          |
|----|---------------------------|----|--------------------------|
| 11 | <i>Wind and/or snow</i>   | 45 | <i>Another insect</i>    |
| 12 | <i>Frost</i>              | 52 | <i>Wood-decay fungus</i> |
| 15 | <i>Other climate</i>      | 53 | <i>Gremmeniella</i>      |
| 22 | <i>Root twisted</i>       | 55 | <i>Other fungus</i>      |
| 31 | <i>Moose</i>              | 71 | <i>Fire</i>              |
| 35 | <i>Other vertebrates</i>  | 91 | <i>Other</i>             |
| 42 | <i>Spruce bark beetle</i> |    |                          |

If the cause of the felling has been assessed as remediation after damage, a cause of the damage must also be stated.

**ENERGI?**

20 m surface

Code Has the energy range been taken out?

0 *No, no withdrawal of energy range.*1 *Yes, withdrawal of energy range.*

For the felling measures final felling, thinning, young forest cleaning and miscellaneous felling carried out in the last 5 years, it must be stated whether, in connection with the felling, it has been used or is planned to be used as an energy source. Heaps of branches and tree tops on a final felled area shall be classified as a withdrawal. Recovery of stumps is not included but is registered as a separate measure.



## **AGE AVV**

20 m surface

Age of felled trees (years)

Codes: 001-999

The age is determined on productive forest land and shall refer to the basal area weighted total age and is determined on the basis of the number of annual rings in the stump cut with addition to age at stump height of 3-5 years. The variable is registered only \*for final felling and the season is set as 1.

The same codes apply as for stand age (section 6.4).

## 6.8 MOOSE DAMAGE INVENTORY (ÄBIN)

### 6.8.1 GENERAL

In the moose grazing inventory (ÄBIN), stems are assessed on a sample plot with a radius of 3.5 m with regard to damage. The inventory shall be carried out on volume sample plots in stands where the following conditions are met:

- Maturity class B1-B3.
- Average height 1.0-4.0 m (20 m surface).
- At least 1/10 of the main stems must consist of *pine* or *birch* (20 m surface).

The stems to be inventoried are *pine* and *birch* stems with a height that exceeds 50% of the average height of the two tallest conifers on the sample plot/sub-sample plot (3.5 m radius). If a coniferous tree (one or both) is missing, it/they are replaced by the tallest deciduous tree/trees, regardless of tree species. The two trees must belong to the stand-forming height layer. Clearly overgrown trees that should undoubtedly be cleaned are excluded. Stems that are higher than the higher of the two for which the average height has been determined are not inventoried.

Stems below 0.5 m are not inventoried, however, stems that due to fresh moose grazing fall below the minimum inventory height are included.

Multi-stemmed trees are counted as one individual regardless of where the division is located. For stump shoots smaller than 2 cm, only one, the highest, is included.

This step is not carried out on Gotland.

Fresh damage refers to damage that occurred in season 1. Old damage refer to damage that occurred earlier than season 1. Damage and grazing from season 0 are not included as moose damage but are transferred to

other damage to pine (Other damage to pine).

## 6.8.2 VARIABLES

### MEDELHÖJD

Average height 2 highest (dm)

Codes: 0, 5-99

The variable refers to the *average height of the two tallest trees* on the sample plot (3.5 m) that belong to the stand-forming height layer (for a definition please see previous page). When determining this height, trees that, due to *fresh* damage, are dead or broken off. Such trees are assigned the height they had before the damage. Code "00" is used in the absence of trees or when only one tree is on the sample plot. No further registrations are made in these cases.

### FÄRSK TALL

Only fresh on pine (number)

Codes: 0-99

Refers to the number of pine stems with only fresh, not old, stem damage caused by moose. Damage other than recent moose injuries is not included in the assessment. Only damage that occurred outside the vegetation period is included, which means that top shoot grazing of non-wooded annual shoots, so-called early summer grazing, is not included. Early summer grazing is included in Other damage pine.

Fresh stem damage caused by moose is defined as:

- Top shot grazing; last year's shot grazed or broken.
- Stem fracture; the stem is broken below the top canopy. The tree may be completely dead.

6.8.2 Arealinventering – Älgbetesinventering – Variabler  
6.8.2 Area inventory - Moose grazing inventory - Variables

- Gnawed bark; the bark is gnawed so that the wood has become visible.

## FÄRSK/GAM TALL

Fresh and old on pine (number)

Codes: 0-99

Refers to the number of pine stems with both fresh and old stem damage caused by moose. Injuries other than moose injuries are not included in the assessment.

Stem injury older than season 1 and which gave rise to any of the following malformations and where the cause of the damage was found to be moose is included in ÄBIN as old stem injury.

- Dead tree (only killed by moose).
- Stem fracture.
- Crossbars.
- Bayonet formation.
- Twig.
- Fork formation.
- Multi-stemmed.
- Bark gnawing down to the wood.

In case of doubt as to whether the damage was caused by a moose, the damage is classified as other damage. Older damage is only included if it is higher than 3 dm from the ground.

## GAMMAL TALL

Enbart gamla på tall (antal)

Koder: 0-99

Only old on pine (number)

Codes: 0-99

Refers to the number of pines with only old (season 2 or earlier) stem damage caused by moose. Damage other than old moose damage is not included in the assessment.

### **ÖVR SKADOR TALL**

Only other damage to pine (number)

Codes: 0-99

Refers to the number of pines free from fresh and old (season 1 and earlier) moose damage, but with other damage, which is defined in accordance with damage to sub-sample trees.

→ Please note that this also includes moose damage that occurred in season 0. Only damage higher than 3 dm above ground is included.

### **OSKADAD TALL**

Undamaged pine (number)

Codes: 0-99

Refers to the number of pines free from damage as above.

### **F SKAD VBJÖ**

Fresh grazing on *Betula pendula* (number)

Codes: 0-99

Refers to the number of *Betula pendula* stems with fresh top shoot grazing or fresh stem breaks caused by moose. Only damage and grazing from season 1 are included. Damage other than moose damage is disregarded.

## **EJ F SKAD VBJÖ**

Not fresh on *Betula pendula* (Quantity)

Codes: 0-99

Refers to the number of *Betula pendula* stems without fresh grazing damage caused by moose, i.e. all *Betula pendula* stems that have not been picked up during fresh grazing.

## **F DAMAGE GBJÖ**

Fresh on *Betula pubescens* (number)

Codes: 0-99

Refers to the number of *Betula pubescens* stems with fresh top shoot grazing stem fractures caused by moose. Only damage and grazing from season 1 are included. Damage other than moose damage is disregarded.

## **EJ F SKAD GBJÖ**

Not recent damage to *Betula pubescens* (Quantity)

Codes: 0-99

Refers to the number of *Betula pubescens* stems without fresh grazing damage caused by moose, i.e. all *Betula pubescens* stems that have not been picked up during fresh grazing.

## 7 TREE MEASUREMENT, DEAD WOOD AND FF OBJECTS

### 7.1 GENERAL

*Stem counting* involves measuring with a caliper and recording diameter and tree species on the volume sample plots. On permanent sample plots, coordinates of certain trees and certain information about trees with previously set coordinates that no longer exist on the surface are also recorded. When calculating dead trees, certain data are also recorded to describe the characteristics of the dead wood. Furthermore, stumps after trees with set coordinates are re-inventoried to determine the extent of stub mining. Stem counting is carried out on all land use classes except *developed land, freshwater* and *saltwater*. Exceptions to the stem counting are made for avenue trees, energy forest plantations, Christmas tree farms and fruit tree plantations. Care trees and protected trees are counted, but are not bored in case of selection for sub-sample trees.

Stem counting is carried out on temporary volume surfaces within circular plots with a radius of 3.5 or 7 m, depending on the diameter of the tree. On permanent sample plots, the corresponding surface sizes are 3.5 and 10 m radius respectively. In addition, live small trees, < 40 mm in diameter, are counted on two symmetrically laid-out circular plots with a radius of 1 m.

Stem counting of live trees and dead trees takes place separately and registration takes place in different menus. Registration of broken stumps is also done in a separate menu.

This section also describes the inventory of certain flora/fauna objects (FF objects). Most of the items to be inventoried are associated with the trees that are stem counted, preferably the dead trees. Inventory of FF objects is done on **Pö**tracts. The inventory takes place on volume areas on the land use classes *productive forest land, natural grazing, morass, rock and some other impediments, subalpine coniferous woodland, high mountains*. FF items are recorded in a special menu. Live trees and dead wood



measured with a caliper are listed in the FF object menu and can be listed as substrates if applicable.

The following table presents different inventory elements:

| Step  | See page |
|---|----------|
| <b>7.2 Instructions for stem counting</b> .....                                 | 7:7      |
| <b>7.3 Coordination on permanent surfaces</b> .....                             | 7:19     |
| <b>7.4 Registrations live trees with diameter <math>\geq</math> 40 mm</b> ..... | 7:21     |
| <b>7.4.1 Temporary sample plots</b> .....                                       | 7:21     |
| Assessed base surface( <b>BEDÖMD GY</b> ).....                                  | 7:21     |
| Overgrowing? ( <b>FÖRVÄXANDE?</b> ) .....                                       | 7:22     |
| Diameter ( <b>DIAMETER</b> ) .....  | 7:22     |
| Tree species ( <b>TRÄDSLÄG</b> ) .....  | 7:23     |
| <b>7.4.2 Permanent sample plots</b> .....                                       | 7:24     |
| Status for re-measured tree( <b>STATUS</b> ).....                               | 7:24     |
| Diameter ( <b>DIAMETER</b> ) .....  | 7:26     |
| Tree species ( <b>TRÄDSLÄG</b> ) .....  | 7:26     |
| Distance to the tree ( <b>AVSTÅND</b> ) .....                                   | 7:26     |
| Direction to the tree ( <b>RIKTNING</b> ) .....                                 | 7:27     |
| Is the felled re-measured tree still there? ( <b>STAM</b>                       | 7:27     |
| Felling season ( <b>SÄSONG</b> ).....   | 7:28     |
| <b>7.5 Registration of small trees</b> .....                                    | 7:29     |
| Small tree dimension class ( <b>DIMKLASS</b> ).....                             | 7:30     |
| Tree species for small trees ( <b>TRÄDSLÄG</b> ) .....                          | 7:31     |
| Number of small trees ( <b>ANTAL</b> ).....                                     | 7:31     |
| <b>7.6 Inventory of dead wood</b> .....   | 7:34     |
| <b>7.6.1 General</b> .....  | 7:34     |
| <b>7.6.2 Registrations</b> .....  | 7:39     |
| Is there dead wood in a pile? ( <b>DÖD VED I HÖG?</b> ) .....                   | 7:39     |
| Number of stems parts dead wood in pile ( <b>ANTAL</b> ) .....                  | 7:40     |
| Status of dead wood object ( <b>STATUS</b> ).....                               | 7:41     |
| Position of the object ( <b>POSITION</b> ).....                                 | 7:42     |
| Object diameter ( <b>DIAMETER</b> ).....  | 7:43     |

→

| <b>Step</b>   | <b>See page</b> |
|---|-----------------|
| Tree species ( <b>TRÄDSLAG</b> ).....                                     | 7:44            |
| Distance to object ( <b>AVSTÅND</b> ) .....                               | 7:44            |
| Direction to object ( <b>RIKTNING</b> ) .....                             | 7:444           |
| Deduction Season ( <b>AVG SÄSONG</b> ).....                               | 7:45            |
| Reason of deduction ( <b>AVG ORSAK</b> ).....                             | 7:45            |
| Felling season for felled object ( <b>AVV SÄSONG</b> ) .....              | 7:46            |
| Is the object a part of a root? ( <b>ROTDEL?</b> ).....                   | 7:47            |
| Does the object have full length or height? ( <b>FULL LÄNGD?</b> ) .....  | 7:48            |
| Height or length of dead wood ( <b>HÖJD/LÄNGD</b> )....                   | 7:48            |
| Top diam. horizontal dead wood (non root part)                            | 7:49            |
| Degradation rate ( <b>NEDBRYTNINGSG</b> ) .....                           | 7:49            |
| Are there infestations of spruce bark beetle? ( <b>GRANBORRE?</b> ) ..... | 7:51            |
| <b>7.7 Inventory of FF objects</b> .....                                  | 7:55            |
| <b>7.7.1 General</b> .....  | 7:55            |
| <b>7.7.2 Registrations</b> .....  | 7:59            |
| FF-substrate ( <b>SUBSTRAT</b> ) .....                                    | 7:59            |
| Distance to the FF substrate ( <b>AVSTÅND</b> ).....                      | 7:60            |
| Direction to the FF substrate ( <b>RIKTNING</b> ).....                    | 7:60            |
| The diameter of the anthill ( <b>STACKDIA</b> ) .....                     | 7:60            |
| The height of the anthill ( <b>STACKHÖJD</b> ) .....                      | 7:61            |
| Type of FF object ( <b>FF-TYP</b> ) .....                                 | 7:61            |
| Type of hole ( <b>HÅLTYP</b> ).....                                       | 7:62            |
| Type of woodpecker signs ( <b>SPÅRTYP</b> ) .....                         | 7:63            |
| Woodpecker signs age ( <b>HACKÅLD</b> ).....                              | 7:63            |
| Wood fungus ( <b>VEDSVAMP</b> ).....                                      | 7:64            |
| Size of wood fungus ( <b>STORLEK</b> ) .....                              | 7:66            |
| <b>7.8 Inventory of broken stumps</b> .....                               | 7:              |

## 7.2 ANVISNINGAR FÖR STAMRÄKNING

Tree diameter is measured at breast height (with a caliper). The breast height is located 130 cm above the ground surface. If the tree is leaning or curved, the distance from the soil surface along the length axis of the tree is measured. The soil surface refers to the upper boundary surface of the humus layer or, in its absence, of the bare mineral soil. On sloping soil, the distance on the side of the tree that corresponds to the average level of the soil is measured. In some cases, it is difficult to assess the level of the soil surface. This applies, for example, to wet soils, and where trees grow on older stumps or stones. Often the top branching point of the roots is a good approximation of the level of the soil surface in these positions. See Figure 7.1 below.

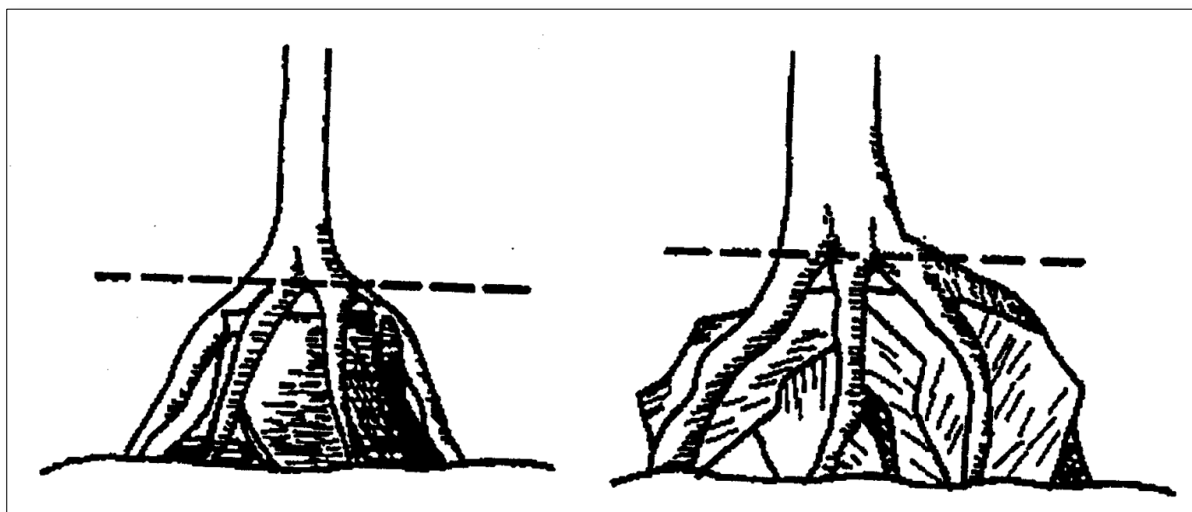

**Fig. 7.1** *Approximation of the position of the soil surface where trees grow on stumps or stones.*

To determine breast height, a stick, exactly 130 cm long, should be used when each tree coarser than 40 mm is measured with a caliper. The team leader must check the caliper height on a daily basis.

The caliper must be held perpendicular to the longitudinal axis of the tree, and with the ruler facing the centre of the sample plot. The diameter is indicated in descending mm. In the case of edge trees, they are

considered to belong to the surface if the point at which the seed can be considered to have germinated falls within the surface. In this respect, the following applies:

- Trees that do not lean and are straight between the ground surface and breast height are considered to belong to the plot if the midpoint of the caliper measurement at breast height falls within the plot.
- For trees that lean or are crooked between the ground surface and breast height, an assessment is made of whether the germination point of the seed falls within the plot or not. To support this assessment, the centrepoint of a caliper measurement can be used at stump height.

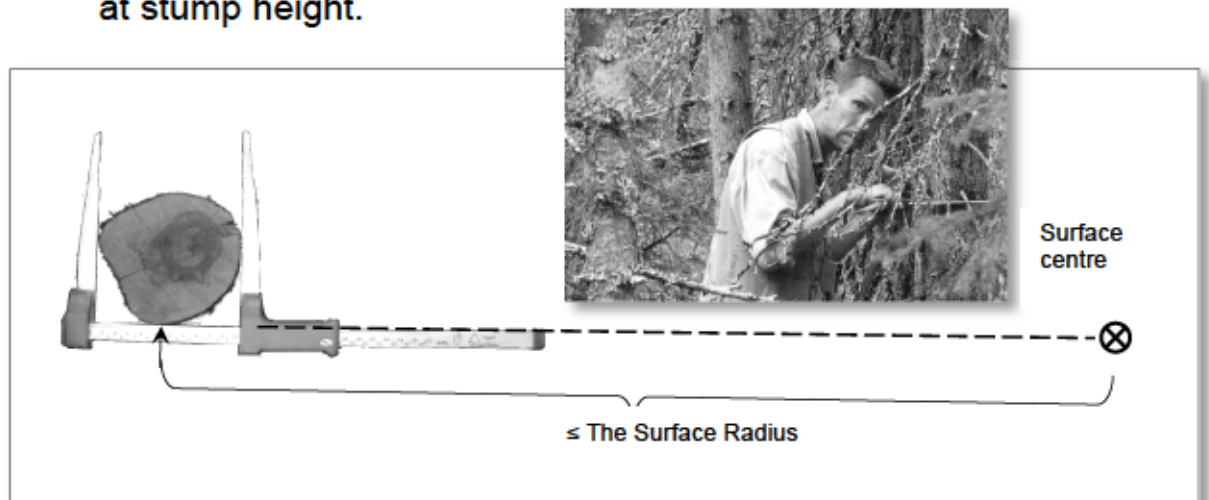

**Fig. 7.2** *The caliper must be held perpendicular to the longitudinal axis of the tree and with the ruler facing the centre of the sample plot.*

If the place for caliper measurement lands on an abnormal unevenness, it is moved along the shortest path, up or down, past this unevenness. In the absence of bark at the caliper measurement site, no addition is made.

On broken trees to be recorded, sometimes the breast height is on the broken part. The tree is then measured with a caliper at this point. The height of broken trees without replacement top is set to the original height. If there are replacement tops, the height is determined as the height to the

new top. This also applies to small trees.

On sloping ground, it is sometimes necessary to plumb the horizontal distance between the tree and the surface centre, possibly in stages.

Even for horizontal dead trees with a root part, if the germination point of the seed is judged to fall within the sample plot, the tree should be measured with a caliper, and otherwise not. For horizontal dead tree parts that are not root parts, if the thick end is within the plot, the part should be measured, otherwise not. When inventorying temporary sample plots of horizontal dead wood which is part of a root, in extreme conditions after windthrow, the principle of the "germination point" of the seed may be waived. Instead, a point is used on the top of the stem at breast height to determine whether or not the tree should be counted. All objects that are root parts must be measured in the same way.

Horizontal broken dead or sawn trees are considered an object if the distance between the breakage surfaces of the parts is less than 2 m and it is certain that the parts originate from the same tree. If the distance exceeds 2 m, the parts are considered separate objects.

To determine whether a horizontal object is related to a particular stump, the distance may exceed 2 m. This determines whether or not the object should be measured as a root part. If the position of the object has changed in this way, new coordinates are specified based on the location of the root end. IF the root end is located outside the plot, "not found" is specified for the Status variable.

The trees measured with a caliper are marked with a colour spot at breast height. On permanent surfaces, the marking shall be made as discreet as possible. Horizontal dead wood is also coloured at breast height or 1.3 m from the rough end (for non root parts). Trees less than 40 mm at breast height are not colour-marked. Trees that have been measured and found to be outside the plot are marked with a colour stain about 5 dm up on the stem.

Depending on the tree diameter, the caliper measurement takes place as follows:

- *Live trees and standing dead trees with breast height diameter  $\geq 100$  mm* are measured with a caliper within an area with a radius of 7 m on temporary sample plots and within an area with a radius of 10 m radius on permanent sample plots.
- *Live trees with breast height diameters of 40-99 mm* are measured with a caliper within an area with a radius of 3.5 m on both temporary and permanent sample plots.
- *Live trees and plants with a height of  $\geq 1$  dm and a diameter  $< 40$  mm* are counted on the land use classes 1, 4, 5, 6 and 7 and in terms of tree species in four dimension classes on two circular sample plots with a radius of 1.0 m placed within the 3.5 m area as described in figure 7.3. On other land use classes, only small trees  $\geq 1.3$  m are stem-counted.
- *Horizontal dead trees (root parts) with breast height diameter  $\geq 100$  mm and horizontal dead tree parts (without root parts) with a diameter of  $\geq 100$  mm at a distance of 1.3 m from the rough end* are measured with a caliper within an area with a radius of 7 m radius on temporary sample plots and within an area with a radius of 10 m radius on permanent sample plots.

The sample plot radius refer to the horizontal distance. On permanent sample plots, the centre of the surfaces with a radius of 1 m are marked with a blue plastic stick which is left behind. If, upon re-inventory, only one blue stick is found, the other stick is re-installed based on the recovered stick. If no stick is found, new ones are installed according to the guidance of figure 7.3.

The distance to the trees is determined by electronic distance meter. For trees near the periphery of the surface  $\pm (3$  dm), tape measure is used. The electronic distance meter shall be calibrated before the caliper measurement on each surface. The calibration is set out in Annex B1.

The appearance of the volume sample plot is shown in figure 7.3 below.

Please note that broken trees must, in some cases, be registered twice. First, the standing part (if the height  $\geq 1.3$  m) is recorded as a live tree or standing dead wood and subsequently the horizontal part (if thick end is inside the plot) as horizontal dead wood.

Species that are normally bush-shaped, such as hazel (*Corylus avellana*), the majority of *salix* species and *Prunus padus*, are counted as trees only if they have a reasonably straight stem shape and are thicker than 50 mm at breast height. However, *Juniperus communis* is always counts as shrub.

*Sorbus aucuparia* and *Salix caprea* are always included in the case of stem counting and when counting small trees. However, when describing tree layers, stem counts and tree species mixture, *Sorbus aucuparia* and *Salix caprea* < 20 mm are not included, instead these are included in the description of the bush layer.

For stump shoots less than 20 mm, only one shoot per stump is included. The highest shoot is selected. For more detailed information, see section 7.5.

Double-stem trees are recorded as two trees when the split is below breast height. The dividing point is considered to coincide with the lowest point where the stems most likely fall apart upon cutting. However, double stems with a diameter < 40 mm always count as one individual.

A tree is considered dead if it completely lacks live needles, leaves or buds. In addition, horizontal trees are always counted as dead. Standing or leaning trees suspended in other trees are counted as dead if it is assessed that the root system is so damaged that it has stopped functioning.

Cut-off high stumps with remaining green needles or leaves are counted as live trees. If such a tree is treated as a sub-sample tree, stem fractures are listed as damage. In connection with stump inventory, these high stumps must also be measured with a caliper as stumps. If such a live high

stump is a re-measured tree, "live tree" should be indicated for the Status variable and caliper measurement should take place as usual. Re-measured trees that have been cut to high stumps since the last inventory and are now dead are listed as dead for purposes of Status.

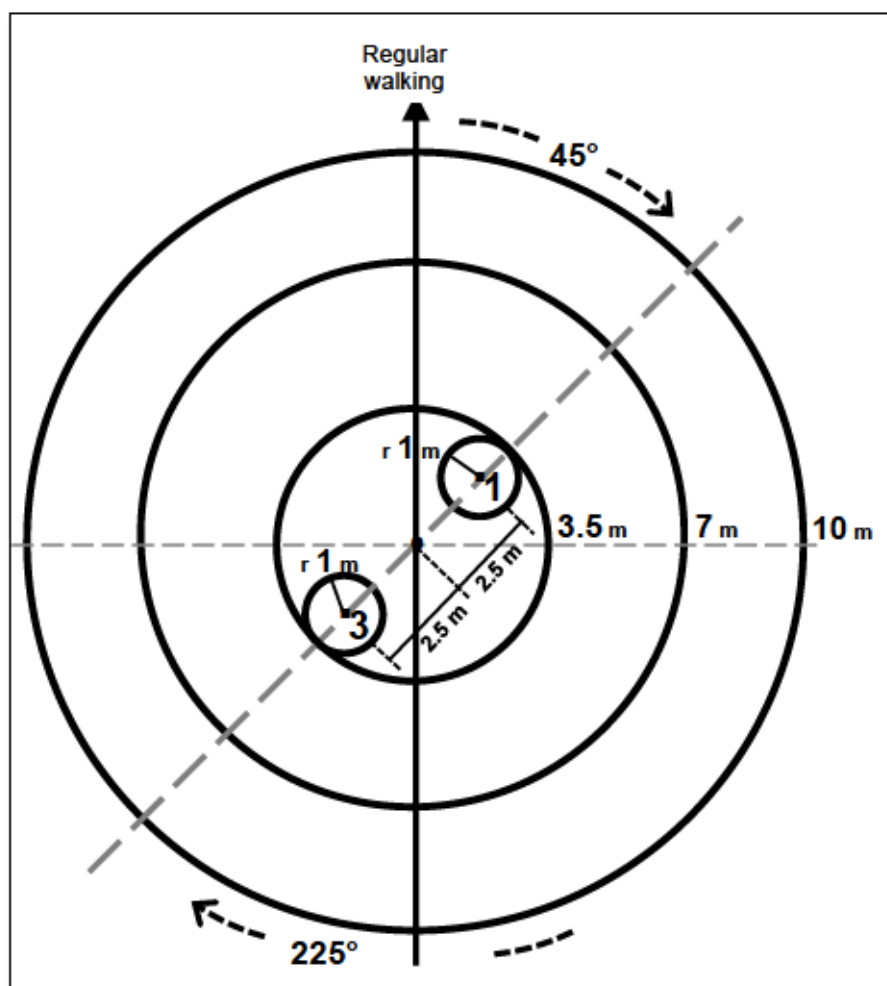

**Fig. 7.3** *Circular sample plots for stem counting.  
Radii: 10.0 m, 7.0 m, 3.5 m and 1.0 m.  
Small plots laid out in directions 45° (Nos 1) and 225° (No 3) in relation to regular walking direction with its centre 2.5 m from the sample plot centre.*

Radii: 10.0 m alt. 7.0 m, 3.5 m and 1.0 m.

Small areas laid out in the directions 45° and 225° in relation to the regular walking direction with its centre 2.5 m from the sample plot centre.



## 7.3 SETTING OF COORDINATES ON PERMANENT SURFACES

On permanent sample plots, coordinates shall be set for live trees and dead wood measured. In addition, coordinates are set for FF substrates. Setting coordinates means recording polar coordinates, i.e. compass direction from the surface centre (degrees) and distance between objects and surface centres in dm.

Objects for which coordinates were set previously (live trees or dead wood) that are now to be re-inventoried can be found in the field computer as so-called re-measured objects. You can select the object that you wish to measure. Objects for which coordinates were set previously are also shown in the so-called tree map or plot.

Upon re-inventory on permanent plots previously registered coordinates shall be checked. If found obviously fault they should be corrected

For the setting of coordinates of live and dead trees, the following applies:

- For trees with a diameter  $\geq$  of 100 mm, coordinates are set within the entire 10 m area. This also applies to dead wood. For horizontal dead wood, the coordinates of the assessed germination point (root part) or coordinates of the thick end (non root part) are specified.
- For trees with diameters of 40-99 mm, coordinates are set within the entire 3.5 m area. The setting of coordinates refers to the centre of the tree at ground level. Normally, direction and distance can be measured to the tree at breast height. However, for leaning trees, the coordinates must be determined at ground level.

For dead wood in piles and ant stacks (FF objects), the coordinates of the centre of the pile and stack are recorded.

## 7.4 REGISTRATIONS LIVE TREES WITH DIAMETER ≥ 40 MM

### 7.4.1 TEMPORARY SAMPLE PLOTS

Sem counting on temporary sample plots is done at the sub-sample plot level. Absence of trees is indicated by selecting "*Absence of sample trees*" when the menu opens.

#### BEDÖMD GY

Assessed basal area for the sample plot for caliper measurement of tree diameter in breast height (dbh) (m<sup>2</sup>/ha)

Codes: 1-99

An assessment of the base surface in m<sup>2</sup>/ha must be made for the sample plot for caliper measurement of tree diameter in breast height (dbh). In the case of split sample plots, the assessment refers to the base surface of the sub-sample plot. The assessment is based on relascope measurement. Overgrown trees are not included in the assessment. The data is used to calculate the selection probability associated with the sub-sample tree selection. The diagram on the next page can be used to support the assessment.

#### FÖRVÄXANDE?

Code Are there pregrowing trees on the surface?

0 No

1 Yes

Pregrowing trees are seed trees or other over storey trees with, from the main stock, a very different diameter. Such trees should have a different selection probability than other trees in the selection of the sub-sample trees. The variable is recorded to control the application in the data collector. The procedure is applied only if the degree of development of the sample plot corresponds to the maturity class B2-C2.

## **DIAMETER**

Diameter of tree measured with caliper (mm)

Codes: 40-9999

The diameter recorded is diameter at breast height.

## **TRÄDSLAG**

Tree species codes, see Annex B9.

## **FÖRVÄXANDE?**

Code Is the tree pregrowing?

0 No

1 Yes

If it has previously been stated that there are pregrown trees are on the plot, for each tree measured with a caliper, indicate whether or not the tree is pregrown.

## 7.4.2 PERMANENT SAMPLE PLOTS

Stem counting on permanent sample plots is done at the sample plot level, i.e. independently of the sub-sample plot.

The field computer displays a list of so-called re-measured trees. When stem counting, trees from this list can be selected or a new, not previously inventoried tree can be registered. If there are no re-measured trees and no trees on the surface, this is indicated by selecting "*Absence of sample trees*" when the menu opens.

### STATUS

| Code | Status of re-measured tree   |
|------|--|
| 1    | <i>Live trees</i>  |
| 3    | <i>Should not be measured with a caliper according to applicable rules</i>   |
| 4    | <i>Felled live tree. For trees <math>\geq 100</math> mm, the stem has been or is likely to be used. For trees <math>&lt;100</math> mm regardless of whether it has been used or not.</i>   |
| 5    | <i>Dead tree. The tree has died since the last inventory (also includes manufactured high stumps) or the re-measured tree <math>\geq 100</math> mm that has been felled and remains. Trees that have died since the last inventory and then felled are also included here (as dead wood and given the Status = "4").</i> |
| 6    | <i>Tree not found</i>  |
| 9    | <i>The tree is on a land use class where stems are not counted</i>   |

The variable is recorded for trees with previously set coordinates. Code "3" is used for trees that do not meet the criteria for being measured, i.e. diameter requirements are not met or the tree is outside the sample plot for caliper measurement of tree diameter in breast height (dbh). For trees

## 7.4.2 PERMANENTA PROVYTOR

### 7.4.2. Stem count, dead wood & FF object –

Registrations live trees with diameter  $\geq 40$  mm – Permanent sample plots

with previously set coordinates that have died since the previous inventory, the code "5" is given. The tree will then be "referred" to the Dead Wood menu and recorded in connection with the inventory of dead wood. If the tree has died, been felled and used, the code "5" is specified and the tree is given the code "4" for the Status variable in the Dead Wood menu. Trees that, in connection with a split change and in combination with a change in land use class, have ended up on a land use class that is not stem-counted must be registered with code 4 or 9.

### **DIAMETER**

Diameter of the tree measured with caliper (mm)

Codes: 40-9999

The diameter recorded is diameter at breast height.

### **TRÄDSLAG**

Tree species codes, see Annex B9.

### **AVSTÅND**

Distance to the tree (dm)

Codes: 0-100 (*diameter  $\geq 100$ mm*)

0-035 (*diameter 40-99 mm*)

The variable is recorded if the coordinates of a re-measured tree are incorrect as well as in coordinate setting of new trees.

### **RIKTNING**

Direction to the tree (degrees)

Codes: 1-360

The variable is recorded if the coordinates of a re-measured tree are incorrect as well as in coordinate setting of new trees.

7.4.2 PERMANENTA PROVYTOR  
7.4.2. Stem count, dead wood & FF object –  
Registrations live trees with diameter  $\geq 40$  mm – Permanent sample plots

**STAM KVAR?**

Code Is the felled re-measured tree still there?

- 0 *No. The tree is not there or the tree is still there, but will probably be used.*
- 1 *Yes. The tree is still there and is unlikely to be used.*

The variable is recorded for re-measured trees  $< 100$  mm at breast height that have been felled.

**SÄSONG**

Code Felling season

- 0 Season 0
- 1 Season 1
- 2 Season 2
- 5 Seasons 3-5

For delimitation of the season see section 6.7.

## 7.5 REGISTRATION OF SMALL TREES

Registration of small trees is made on a full 1 m-area regardless of split when the centre of the small area is on a land use class that is stem-counted. If there are no trees, this is indicated by selecting "*Absence of small trees*" when the menu opens. The selection of small plots for registration is made in the menu overview. Area number 1 is positioned forward to the right in the regular walking direction and area 3 is located backwards to the left in the regular walking direction (figure 7.3).

Small trees are handled differently depending on whether they are classified as "individual stem" or as a "stump shoot".

All stems regardless of size are counted if they are classified as an "individual" stem.

Stump shoots are treated differently, see figures 7.5 and 7.6. All stump shoots 20-39 mm are counted. For stump shoots less than 20 mm, only one shoot per bouquet is counted. The tallest shoot is selected. The bouquet of shoots can come from a stump after a sawn or broken stem, or from a depressed branch/stem or superficial root. Shoots are considered to belong to the same bouquet if it can be concluded that they have "root contact" with each other and are located within 5 dm from the centre of the bouquet.

The selected shoots in a bouquet are counted if the centre of the bouquet is located within the periphery of the circle surface, see figures 7.5 and 7.6. If the shoots start from a stump, then the stump is the centrepoint of the bouquet. If the shoots do not come from a stump, then the centre of gravity for the shoots included in the bouquet is the centrepoint of the bouquet.

### DIMKLASS

Small tree dimension class

*Height 1.0-4.9 dm (only on land use classes 1, 4, 5, 6, 7)*

*Height 5.0-12.9 dm (only on land use classes 1, 4, 5, 6, 7)*

*Diameter 0-19 mm*

*Diameter 20-39 mm*

7.5 REGISTRERING AV SMÅTRÄD  
7.5 REGISTRATION OF SMALL TREES

When the menu is opened, the dimension class for small trees is selected for registration. For the selected dimension class, tree species and number are then recorded.

### TRÄDSLAG

Tree species codes, see Annex B9.

### NUMBER

Number of small trees for tree species and dimension

Codes: 1-99

The number of small trees per tree species and dimension class is calculated and recorded. Should there be more than 99 trees, the code "99" is entered.

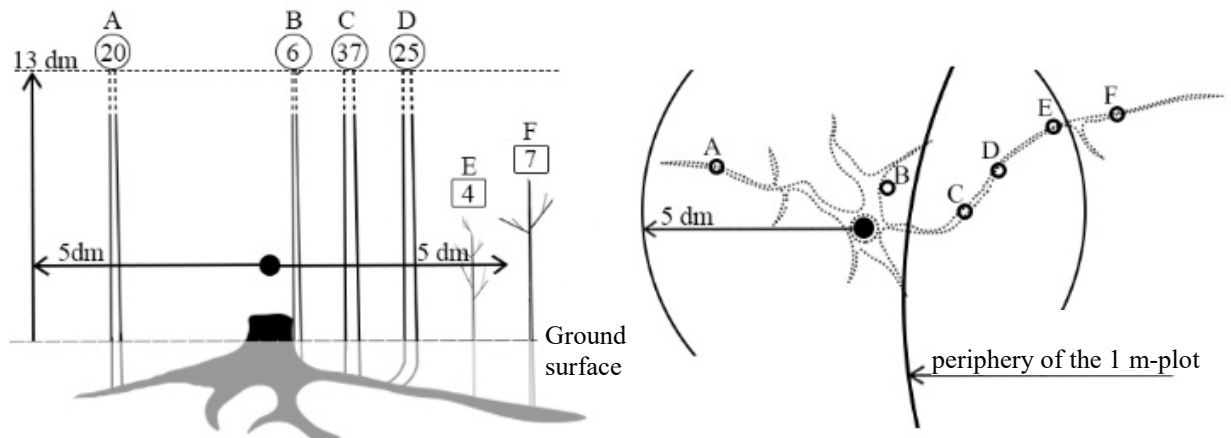

**Figure 7.5** On the left: Shoot near a stump. Shoot A-E belongs to the bouquet, of which A-D should be counted. Shoot F counts as an individual stem.

On the right, the shoots are shown from above together with the circular periphery of the small area. In the example, the bouquet should not be counted, but only the individual shoot F.

- The centrepoint of the bouquet
- Diameter of the shoot
- Height of the shoot



7.5 REGISTRERING AV SMÅTRÄD  
7.5 REGISTRATION OF SMALL TREES

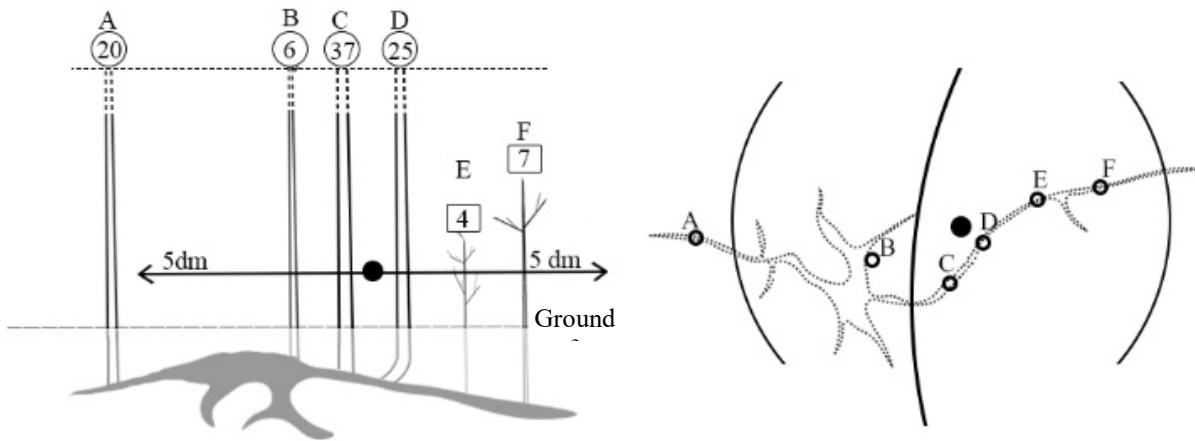

**Figure 7.6** On the left the same shoot as in figure 7.5. But the shoots cannot be linked to a stump. Shoot B-F belong to the bouquet, of which B, C and D should be counted. Shoot A counts as a single stem. On the right, the shoots are shown from above together with the circular periphery of the small area. In the example, the bouquet should be counted, i.e. shoots B, C and D. The individual shoot A must not be counted.

## 7.6 INVENTORY OF DEAD WOOD

### 7.6.1 GENERAL

The inventory refers to stem wood from dead trees and includes the recording of the following variables:

- Diameter
- Tree species
- Distance and direction (permanent sample plots)
- Position
- Height (standing tree)
- Length (horizontal tree)
- Degree of degradation
- Infestation of spruce bark beetle
- Reason for deduction
- Deduction season
- Felling season for felled dead wood

A tree is considered dead if it completely lacks live needles, leaves or buds. In addition, horizontal trees are always counted as dead. Standing or leaning trees suspended in other trees are counted as dead if it is assessed that the root system is so damaged that it has stopped functioning. Cut-off high stumps on which there are still green needles or leaves do not count as dead wood.

Newly felled, not yet removed stems should not be registered. On the other hand, forgotten reprocessed stems, individual as well as in piles (pulpwood piles, woodpiles, etc.) should be recorded. However, felling residues in the form of branches are not inventoried.

Stems that are so degraded that the stem shape can no longer be distinguished are not recorded. On stems where the splint wood is completely or partially gone, for example, old pine trunks lying on the ground, the current diameter is caliper measured.

Stems that have broken down from the inside, but still retain all or part of wood from the sheath surface, are caliper measured if the diameter, *in the direction of the caliper*,  $\geq 100$  mm. The degradation rate is set based on the degradation of the remaining wood.

During the inventory, no clearing of felling residues should be done to look for trunks lying on the ground. On fully or partially overgrown stems, the trunk must be cleared so that the diameter and length can be measured. Diameter should be measured on bark if available but under bark in the absence of bark. On standing and leaning trees, the diameter is measured at breast height. This is also done on horizontal trees that are root parts. On horizontal tree parts that are not a root part, a diameter of 1.3 m from the thick end and the length and top diameter of the tree part are measured.

If there is horizontal dead wood that is multi-stemmed, all stems  $\geq 100$  mm in diameter at breast height (root parts) or 1.3 m above the thick end (non root part) are measured.

The height of standing and leaning dead trees is recorded only if the height of the remaining stem  $\leq$  is 90 % of the original height. On horizontal dead trees that are root parts, the length is measured according to the same rules as the height.

Tree species are registered with the same codes as for live trees, see Annex B9.

Five classes of degradation rates are included. The rate of degradation is assessed on the volume of the registered stem part.

On plots where there is dead wood in a pile, such as forgotten woodpiles, etc., it is possible to register several objects in bulk. In these cases, the number of stems or stem parts (at least 5) and the assessed base area weighted mean diameter, average length and other variables included are recorded. In this procedure, the stem parts must be of the same tree species and rate of degradation. In addition, the deduction season and the reason for deduction must be the same. Such a pile is included if its centre is within the plot.

## 7.6.2 REGISTRATIONS

Inventering av död ved görs på tillfälliga ytor på delytenivå. På permanenta provytor görs inventeringen på påslagsnivå, alltså oberoende av delyta.

Inventory of dead wood is done on temporary sample plots at the sub-sample plot level. On permanent sample plots, the inventory is done at the level of the sample plot centrepoint, i.e. independently of the sub-sample plot.

On permanent plots, the field computer is showed a list of re-measured objects of dead wood and dead wood "referred" from the stem count. When registering, items from this list can be selected a new, previously non-inventoried object can be selected. If there is no dead wood or, on permanent plots, re-measured objects of dead wood, this is indicated by selecting "*Dead wood missing*" when the menu opens.

### DÖD VED I HÖG?

Code Is there dead wood in a pile?

0 No  
1 Yes

To register dead wood in piles, enter this by registering "Yes" for the variable Dead wood in pile?. When registering new dead wood, hover on the variable Position and go back to the variable Dead wood in pile? and change the value "No" (default value) to "Yes". A pile is measured if the centre of the pile falls within the sample plot/sub-sample plot.

### ANTAL

Number of stems dead wood in pile

Codes: 5-999

The number of stem parts indicated must be of the same tree species and rate of degradation. In addition, the deduction season and the reason for

deduction must be the same. If any of these variables differ, the pile is split and homogeneous parts of the pile are described separately.

## STATUS

| Code | Dead wood object status   |
|------|---|
| 1    | <i>Dead wood object</i>   |
| 3    | <i>Not to be measured with caliper in accordance with applicable rules (e.g. outside the surface or for a small diameter or for a short length due to reasons other than degradation)</i>                   |
| 4    | <i>Felled and recovered</i>   |
| 5    | <i>Rotted away (diameter or length has decreased, or the degree of degradation increased, &gt; 4, due to natural or mechanical degradation so that the object no longer meets criteria for measurement)</i> |
| 6    | <i>Not found</i>  |
| 9    | <i>Object is on land use class where stems are not counted</i>  |

The variable is recorded on permanent sample plots for trees with previously set coordinates. The code "9" is only used for items that, in connection with a split change combined with a change of land use class, ended up on a land use class that is not stem-counted. Note that objects that were horizontal at the last inventory and now, for any reason, have Position = "1" or "2" are recorded with Status = "6" (not found) and the item is registered as new. Horizontal objects at the previous inventory that have now rotted so that the thick end is no longer within the plot are recorded with Status = "5" (rotted away).

## POSITION

| Code | Position of the object |
|------|------------------------|
| 1    | <i>Standing</i>        |
| 2    | <i>Leaning</i>         |
| 3    | <i>Lying</i>           |

Broken trees are recorded as standing if the height of the standing part is  $\geq 1.3$  m, otherwise as horizontal. For trees fractured below 1.3 m, the stump part is included in the horizontal object. Please note that trees fractured above 1.3 m are treated as two objects, one standing and one horizontal. Trees suspended in other trees are classified as standing or leaning.

## **DIAMETER**

Object diameter (mm)

Codes: *100-9999*

For standing or horizontal trees and for horizontal trees that are root parts, the diameter is recorded at breast height. For horizontal tree parts, diameter 1.3 m from the thick end is recorded. The diameter is measured on bark. In the absence of bark, no addition is made, but the measure is taken below bark. For dead wood in a pile, assessed base weighted average diameter is measured for the stem parts of the pile.

## **TRÄDSLÄG**

Codes according to Annex B9.

## **AVSTÅND**

Distance to object (dm)

Codes: *0-100*

The variable is recorded if the coordinates of a re-measured object are incorrect and when coordinates are set for new objects. For dead wood in a pile, the distance to the centre of the pile is recorded.

## **RIKTNING**

Direction to object (degrees)

Codes: 1-360

The variable is recorded if the coordinates of a re-measured object are incorrect and when coordinates are set for new objects. For dead wood in a pile, the direction to the centre of the pile is recorded.

### AVG SÄSONG

| Code | Deduction season            |
|------|-----------------------------|
| 0    | <i>Season 0</i>             |
| 1    | <i>Season 1</i>             |
| 2    | <i>Season 2</i>             |
| 5    | <i>Season 3 and earlier</i> |

Regarding the delimitation of seasons see section 6.7.

### AVG ORSAK

Deduction season = 0, 1 or 2

| Code | Deduction Reason   |
|------|--|
| 11   | <i>Wind and/or snow</i>                                  |
| 21   | <i>Felled</i>  |
| 25   | <i>Human other</i>                                       |
| 31   | <i>Moose</i>   |
| 33   | <i>Beaver</i>  |
| 35   | <i>Other vertebrate</i>                                  |
| 42   | <i>Spruce bark beetle</i>                                |
| 45   | <i>Other insect</i>                                      |
| 51   | <i>Cronartium flaccidum,<br/>Peridermium pini fungus</i> |
| 53   | <i>Gremmeniella</i>                                      |
| 55   | <i>Other fungus</i>                                      |
| 60   | <i>Congestion</i>  |
| 71   | <i>Fire</i>  |
| 91   | <i>Others</i>  |

Deduction season = 3 and earlier (code "5")

|    |               |
|----|---------------|
| 21 | <i>Felled</i> |
| 91 | <i>Other</i>  |



## AVV SÄSONG

Code Felling season for felled object

0 *Season 0*

1 *Season 1*

2 *Season 2*

5 *Season 3 and earlier*

Regarding the delimitation of seasons see section 6.7.

## ROOT PART?

Code Is the object a root part?

0 *No*

1 *Yes*

For horizontal dead wood, indicate whether or not the tree is a root part. Also fractured trees are considered root parts provided that the tree is broken below breast height and the horizontal part is within 2 m of the stump. Furthermore, there must be no doubt that the parts are related. In such a case, when indicating the length of the object, the stump part shall be included.

## FULL LÄNGD?

Code Does the object have full length or height?

0 *Yes*

1 *No*

For standing or leaning trees and root-part horizontal trees, the full length is specified if the remaining stem is > 90 % of the original height/length.

## HEIGHT/LENGTH

Height or length of dead wood (dm)

Codes: *13-500*

For standing and leaning trees, height is assessed by ocular estimation. For horizontal objects, length is measured with a tape measure.

→ *Please note that the entire length of the tree is referred to, including any part outside the sample plot.*

## TOPPDIA

Top diameter for horizontal dead wood, non root part (mm)

Codes: 1-999

The variable is registered for horizontal dead wood that is not a root part. The diameter is measured on bark. In the absence of bark, no addition is made, but the measure is taken below bark.

## NEDBRYTNINGSG

Code Rate of degradation

0 *Raw wood.* Assigned e.g. fresh windthrows as long as green needles or leaves remain. In addition, trees with raw cambium are classified as raw wood even in the absence of live needles or leaves.

1 *Hard dead wood.*  
The volume of the stem consists of more than 90% hard wood with a hard sheath surface. The stem is very slightly affected by wood-degrading organisms.

2 *Some broken dead wood.*  
The volume of the stem consists of 10-25% soft wood. The remaining proportion consists of hard wood. Tools, such as an earth probe, can be pushed through the sheath surface but not through the entire splint wood.

3 *Decomposed dead wood.*  
26-75% of the volume of the stem consists of soft or very soft wood.

4 *Very decomposed dead wood.*

76-100% of the volume of the stem consists of soft or very soft wood. Tools, such as an earth probe, can be pushed throughout the stem. However, a hard core may occur. (Rotten wood is assigned Status = "5".)

**GRANBORRE?**

Code Is there infestation of spruce bark beetle  
(*eight-toothed bark beetle*) season 0?

0 No  
1 Yes

The variable is registered for horizontal dead wood (windthrown or broken trees) with a degradation rate "0" (raw wood) of tree species spruce with a diameter  $\geq 150$  mm (diameter measured at 1.3 m from root or break surface). The bottom 4 metres of the stem and the top of the sheath surface shall be inspected. Search for boreholes, boring dust (brown) or walking systems (Figure 7.7 **A** below) from season 0. Part of the bark is removed for inspection. In case of infestation, several spruce bark beetles usually participate. There is a likelihood of confusion with *six-toothed bark beetle* (star-shaped walking system and usually on weaker parts of the stem, figure 7.7 **B** below) and *Xyloterus lineatus* (white boring dust – as it drills into the wood).

*cont.* →

7.6.2. Stem counting, dead wood & FF items — Dead wood inventory — Registrations

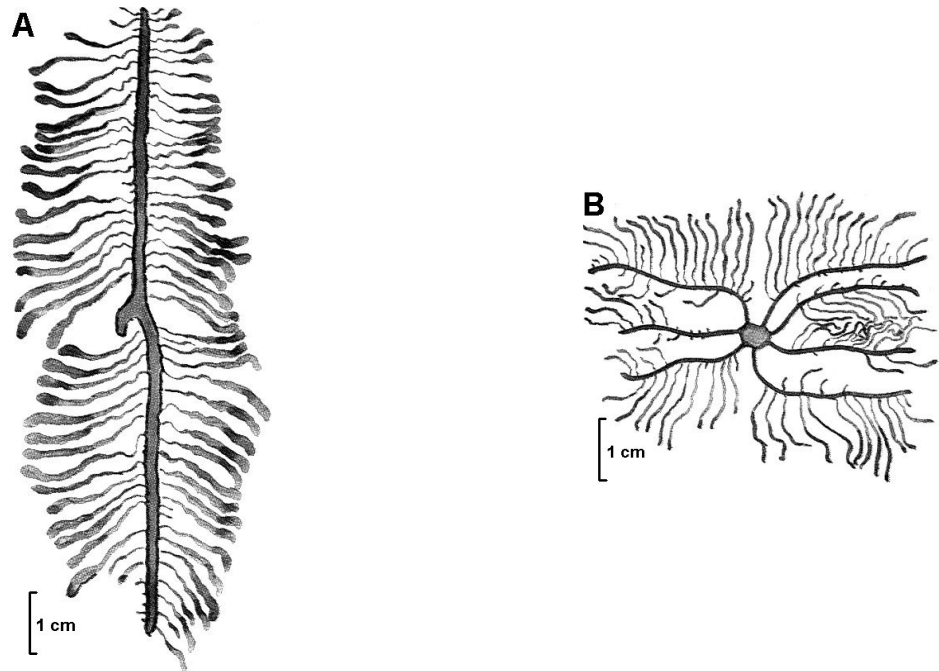

*Ips typographus*

*Pityogenes chalcographus*

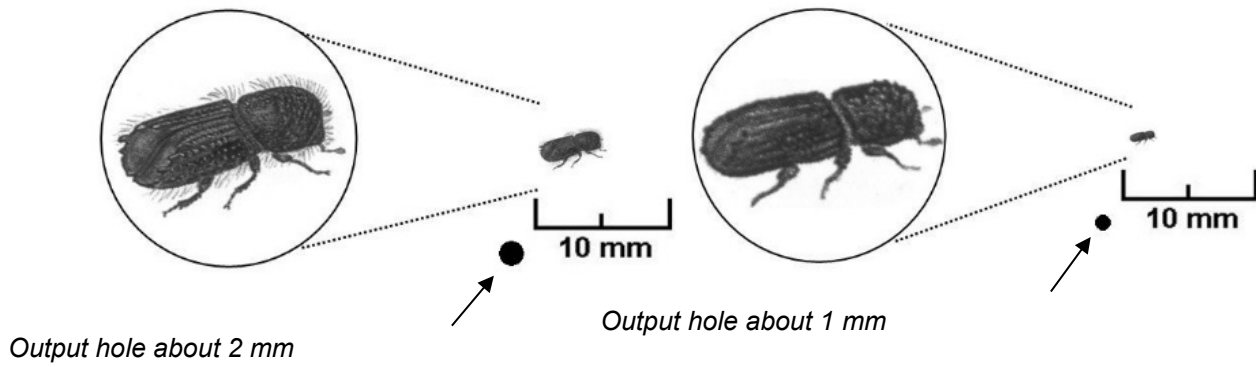

Fig. 7.7

## 7.7 INVENTORY OF FF OBJECTS

### 7.7.1 GENERAL

Specific biodiversity indicators, so-called FF objects (flora/fauna), is inventoried on Pötracts. The inventory is made within the volume sample plot (10 m).

FF objects refer to the following phenomena:

- Woodpecker tracks
- Hole trees
- *Wood fungus*
- Anthills

*Woodpecker* grooves and *tree cavities* shall be recorded if they are present at the bottom 10 metres of standing or leaning dead or live trees  $\geq 100$  mm at breast height measured with a caliper. However, *woodpecker* holes are always registered, regardless of substrates, such as small trees and telephone poles, if these are located within the sample plot for caliper measurement of tree diameter in breast height (dbh). *Wood fungus* are recorded in the same locations as woodpecker signs and tree cavities and also on horizontal dead wood that is a root part if they occur on the bottom 10 meters of the stem. *Anthills* refer to actual stacks of stack ant (*Formica* sp.) Only "live" anthills are recorded. Furthermore, the centre of the stack must be located within the sample plot for caliper measurement of tree diameter in breast height (dbh) and the stack should be at least 2 dm high and have a diameter of at least 3 dm for registration to take place.

The data is recorded in the FF items menu.

Woodpecker tracks are recorded when there are traces of foraging by woodpeckers and in the presence of woodpecker holes. For the indication of a woodpecker hole, fallen residues from at least 20 cones must be present. Two species-typical traces of foraging woodpeckers are

distinguished, traces of three-toed woodpeckers, and the black woodpecker's foraging for carpenter ants deep inside the wood in the lower part of mainly spruce stems. The three-toed woodpecker's groove ring consists of a series of hack holes into the cambium. The holes are located every few centimetres and are arranged as a spiral around the lower part of the stem of mainly spruce, but can also appear on other tree species. Another type of trace is foraging in bark, under bark or into wood. These three variants are registered with a common code. Foraging in or under bark should affect at least 1 dm<sup>2</sup> of the sheath surface of the stem for registration to take place. It is possible to register up to three different types of trace on a single tree. In addition to the trace type, the age of the pecking track must also be recorded.

Hollow trees are recorded when there are hollows in the bottom 10 m of the stem. Several types of holes can be recorded on a single tree. Three types of holes are inventoried. *Black woodpecker type* nesting holes have a hole size of about 9 x 12 cm. *Cavities after* other woodpeckers have a diameter of between 3 and 9 cm and *other nesting holes* can be rot holes after branch breakages and the like, which have a diameter exceeding 10 cm.

Up to three different wood fungus per tree can be registered. In addition to the occurrence of a species, the total hymenial size of the fungus (spore-emitting surface) of the tree should also be estimated.

## 7.7.2 REGISTRATIONS

Registration of FF objects should be done after stem counting and inventory of dead wood. When the FF items menu opens, there is a list of registered live trees and registered dead wood that can be substrates for FF items. In the absence of FF items, select "*FF items are absent*" when the menu is opened.

### SUBSTRAT

FF substrate

*Live trees*  $\geq 100$  mm

*Standing dead wood or horizontal dead wood that is a root part*  $\geq 100$   
mm

*Anthill*

*Woodpecker hole*

Type of substrate with FF object. *Live trees* and *dead wood* are selected from the list in the collector. *Anthill* and *woodpecker hole* can be added.

### AVSTÅND

Distance (dm)

Codes: 0-100

Distance to anthill or woodpecker hole in dm is recorded.

### RIKTNING

Direction (degrees)

Codes: 1-360

Direction in degrees to anthill or woodpecker hole is recorded.

## STACKDIA

Stack diameter (dm)

Codes: 3-99

The diameter of the anthill is indicated in dm. Only stacks with a diameter of at least 30 cm are recorded.

## STACKHÖJD

Stack height (dm)

Codes: 2-40

The height of the anthill is indicated in dm. Only stacks with a height of at least 20 cm are recorded.

## FF-TYP

| Code | FF Type                  |
|------|--------------------------|
| 1    | <i>Hollow trees</i>      |
| 2    | <i>Woodpecker traces</i> |
| 3    | <i>Wood fungus</i>       |

Type of FF object.

## HOLE TYPE

| Code | Type of hole   |
|------|--|
| 1    | <i>Small nesting hole smaller than black woodpecker type (diameter 3-9 cm)</i> |
| 2    | <i>Large nesting hole, black woodpecker type (about 9x12 cm)</i>               |
| 3    | <i>Other large hole, e.g. rot in branch (diameter <math>\geq</math> 10cm)</i>  |



7.7.2 Stamräkning, död ved & FF-objekt – Inventering av FF-objekt – Registreringar.  
7.7.2. Stem-count, dead wood & FF objects — Inventory of FF objects —  
Registrations.

Type of cavity. Recorded for hollow trees.

### SPÅRTYP

Code Type of pecking traces

- 1 *Foraging in the bark, below bark or in the wood.*
- 4 *Foraging for carpenter ants*
- 5 *Track ring from three-toed woodpecker*
- 6 *Woodpecker hole*

Type of trace after woodpecker. Recorded woodpecker traces. For the indication of a woodpecker hole, residues of at least 20 cones must be found.

### HACKÅLD

Code The age of the pecking trace

- 1 *Fresh (season 0 or 1)*
- 2 *Old (older than season 1)*

Age of traces after woodpeckers. Age is determined by means of the pieces that have fallen to the ground.

### VEDSVAMP

Code Wood fungus

- 1 ***Phéllinus chrysolóma*** (*Phéllinus chrysolóma*)
- 2 ***Fomitópsis pinícola*** (*Fomitópsis pinícola*)
- 3 ***Climacocýstis boreális*** (*Climacocýstis boreális*)
- 4 ***Fómes fomentárius*** (*Fómes fomentárius*)
- 6 ***Phéllinus píni*** (*Phéllinus píni*)
- 7 ***Phéllinus igniárius et al.*** (*Phéllinus igniárius et al.*)

Species/species group of wood fungus.

**1** *Phellinus chrysolóma*

Unusual, but more common in the north. Resupinate or console-shaped, often roofed and intertwined. Grows on the stem of dead or dying spruces, rarely pine trees.

**2** *Fomitopsis pinícola*

Common. Hoof-like or console-shaped. Lives on stumps, live and dead stems of both coniferous and deciduous trees.

**3** *Climacocystis boreális*

Unusual, but more common in the north. Soft and juicy fruit body with shank-like base, horned in drought. Grows on the stem of dead or dying spruces.

**4** *Fomes fomentarius*

Common. Hoof shaped. Grows on the stem of live and dead deciduous tree stems. Can be very big.

**6** *Phellinus píni*

Unusual. Hoof shaped. Grows high up on the stem of older live pine trees.

**7** *Phellinus igniarius et al.*

Common. Resupinate, console, or hoof-like shape. This includes the group from the *Phellinus* family that grows mainly on the stem of live and dead deciduous trees. The following species are included: *Phellinus robustus*, *Phellinus pomaceus*, *Phellinus lundellii*, *Phellinus tremulae*, *Phellinus igniarius* (young specimens often tuber-shaped) and *Phellinus nigricans*.

**STORLEK**

| Code | Size of wood fungus (cm <sup>2</sup> )   |
|------|--|
| 0    | <i>Only dead hymenium</i>  |
| 1    | <i>Less than one matchbox (&lt; 18 cm<sup>2</sup>)</i>                             |
| 2    | <i>Larger than a matchbox, smaller than an A6 sheet, (18-156 cm<sup>2</sup>).</i>  |
| 3    | <i>Larger than an A6 sheet, smaller than an A5 sheet, (157-312 cm<sup>2</sup>)</i> |

7.7.2 Stamräkning, död ved & FF-objekt – Inventering av FF-objekt – Registreringar.

7.7.2. Stem-count, dead wood & FF objects — Inventory of FF objects — Registrations.

4 *Larger than an A5 sheet, smaller than an A4 sheet,  
(313-624 cm<sup>2</sup>)*

5 *Larger than an A4 sheet, (> 624 cm<sup>2</sup>)*

The total size of the live hymenium for a species on the tree.

## 9 STUMP INVENTORY

### 9.1 GENERAL

The stump inventory consists of *area inventory*, *site inventory* and *registration of stumps*. The area inventory is registered in the menu Stand description and Completed actions, the site inventory is registered in the menu Site and Tree Layers (tree layers only on non-productive forest land) and registration of stumps is done in the menu Stump caliper measurement. Site inventory and area inventory are not described here, but in Chapter 5, Site inventory and Chapter 6, Area inventory. Stump areas are inventoried on all types of land classes except *developed land*, *freshwater* and *saltwater*. stump plots are laid on the following sample plot centrepoints:

| Region            | Temporary tracts                        | Permanent tracts |
|-------------------|---|------------------|
| <b>01, 21, 22</b> | 200, 500*, 700, 1000*,<br>1200 och 1500 | 300 och 900      |
| <b>03</b>         | 200, 500*, 700, 1000*,<br>1200 och 1500 | 200 och 700      |
| <b>04</b>         | 200, 400*, 600<br>och 800*              | 200 och 600      |
| <b>05</b>         | 100, 300*, 400<br>och 600*              | 100              |

\* *The plot is at the same time a volume storage plot.*

→ *Note that stump plots are never laid on the same sample plot centrepoint as permanent volume plots.*

The stump plots are designed as circular plots with a radius of 7 m, both in permanent and temporary tracts. The plot is only inventoried if it has been affected in any way by felling during season 1. This means that the area is within an action unit where felling has taken place in season 1 and trees have been felled within the 20 m area. However, if the plot is completely outside the clear limit for felling, it must not be inventoried. If the plot has been subjected to further intervention after felling season 1,

for example storm felling or new felling season 0, the area inventory must describe the stand as it looks at the time of the inventory.

If the felling is miscellaneous felling or if the land use class is not productive forest land, an inventory is only carried out if trees have been felled on the 7 m plot and there are stumps 50 mm in diameter at a height of 10 cm above the ground surface.

Regarding the delimitation of the season and the definition of different types of felling, see section 6.6, Actions performed.

The various elements and variables of the stump inventory are described below:

| <b>Step/ variable</b>  | <b>See page</b> |
|--|-----------------|
| <b>9.2 Caliper measurement and registration of stumps.....</b> | <b>9:5</b>      |
| Has the stump been assessed? ( <b>BEDÖMD?</b> ) .....          | 9:8             |
| Stump diameter ( <b>DIAMETER</b> ) .....                       | 9:8             |
| Tree species for felled tree ( <b>TRÄDSLAG</b> ) .....         | 9:9             |
| Where felled trees live? ( <b>LEVANDE?</b> ).....              | 9:9             |
| Type of dead tree ( <b>TYP AV DÖTT</b> ).....                  | 9:9             |
| Dead Tree Deduction Season ( <b>AVG SÄSONG</b> ) .....         | 9:9             |
| Stump height ( <b>STUBBHÖJD</b> ).....                         | 9:11            |
| Remaining trees? ( <b>KVAR?</b> ).....                         | 9:11            |
| Rotten occurrence on stump ( <b>RÖTA</b> ) .....               | 9:12            |
| Rot attack diameter ( <b>RÖTDIAMETER</b> ) .....               | 9:14            |

## 9.2 CALIPER MEASUREMENT AND REGISTRATION OF STUMPS

On the stump plot, i.e. a circular surface with a radius of 7 m, all stumps that are 50 mm or thicker on a low edge at a height of 10 cm above the ground are registered. However, the stump diameter is measured immediately below the saw blade and is stated in descending mm. For tall stumps, the breast height diameter is measured instead in the same way as for stem counts (see section 7.2). Only manufactured high stumps are measured. However, stumps after avenue trees are not measured with a caliper. Before caliper measurement, all felling waste must be moved outside the plot, so that it can be checked that all stumps are actually measured with a caliper.

Stumps at the periphery of the plot are included if the centre of the marrow falls within the plots. In the absence of marrow, e.g. due to rot, the stump is included if its centrepoint radially from the plot centre falls within the plot. Stump after a windthrown tree is considered to belong to the plot if the germination point is deemed to fall within the plot.

Stumps measured with a caliper must be colour-marked in the saw cut.

The stump diameter of ordinary stumps is indicated on bark and is measured on the low edge immediately below the saw cut, perpendicular to the longitudinal axis of the tree.

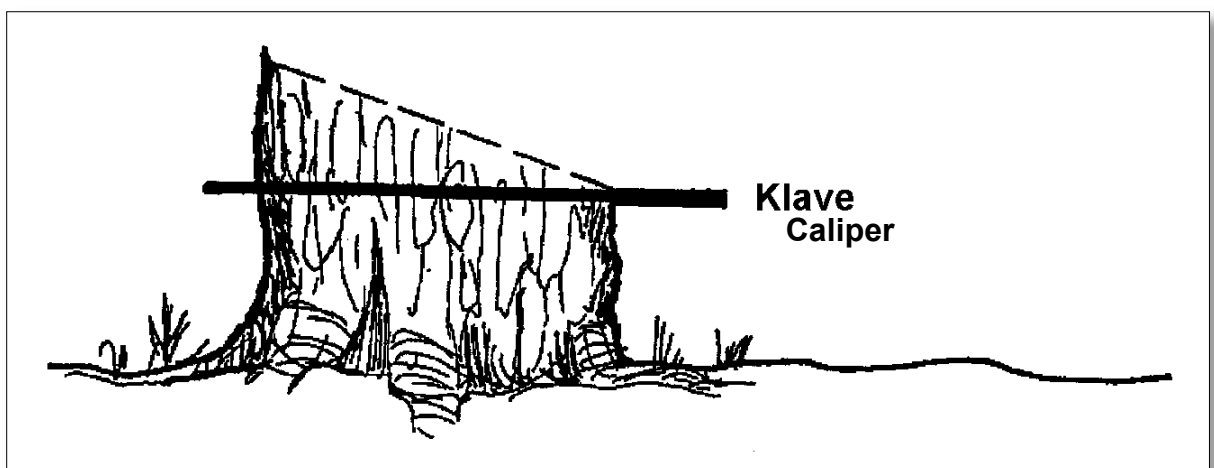

**Fig. 9.1** *Measurement of stump diameter on ordinary stump*

If the tree has not been sawn off but is fractured below breast height and recovered, the diameter is measured immediately below the fracture. Broken stumps higher than 1.3 m are not included, regardless of whether the tree has been recovered or not.

If the bark is damaged or gone, an assessed addition is made for bark. If the stump is broken, the diameter of a corresponding undamaged stump must be assessed.

If stumps 50 mm and thicker have been removed from the plot, or are inaccessible for caliper measurement for other reasons, it must be stated that the registrations of a stump object have been assessed.

In some cases, e.g. where a wall street has been cut and the stumps have been removed, the number of stumps and their diameter can be estimated by an area laid out next to the sample plot.

In some cases stumps to be measured with a caliper may be absent. This is registered by selecting "Absence of stumps" when the menu opens.

The following registrations are made:

### **BEDÖMD?**

Code Has the stump been assessed?

0 No, *the stump has been measured with caliper*

1 Yes, *the stump has been assessed*

### **DIAMETER**

Stump diameter (mm)

Codes: 1-9999

In cases where the stump height exceeds 130 cm, the diameter is measured at breast height according to the same rules that apply to stem counts (see section 7.2).

## TRÄDSLAG

Tree species for felled tree.

Codes:

"1" - "9", see Annex B9.

## LIVE?

Code Was felled tree alive?

0 No, *the tree was dead*

1 Yes, *the tree was alive*

Here it is stated whether the felled tree was live or dead.

## TYP AV DÖTT

Code Type of dead tree

1 *Stump after windthrow*

2 *Other stump*

Windthrow also include trees broken by wind.

## AVG SÄSONG

Code Dead tree deduction season

1 *Season 1*

2 *Season 2*

5 *Season 3 and earlier*



## STUBBHÖJD

Stump height (cm)

Codes: 0-999 cm

For stumps measured with caliper, stump height must also be registered.

→ *Note that the height is stated in cm for both "ordinary" stumps and for tall stumps. However, the height of tall stumps is determined by ocular estimation.*

## KVAR?

Code Remaining trees?

0 *No. The tree does not remain, or the tree remains but will probably be processed.*

1 *Yes. The tree remains and will probably not be processed.*

## RÖTA

Code Occurrence of rot on stump

0 *No rot*

2 *Only non-centred rot*

3 *Solid rot in the centre of the stump*

4 *Loose rot in the centre of the stump*

5 *Hole rot in the centre of the stump*

Four different types of rot are distinguished, one non-centred and three centred. High stumps are bored at breast height for rot determination.

### 2 *Only non-centred rot*

Non-centred rot means e.g. rot as a result of old stamping or driving damage. The infestation is located in the sapwood, usually near the stump mantle surface. No distinction is made between solid and loose rot.

**3** *Solid rot in the centre of the stump*

Solid rot (aniline wood, light and dark rot) means rot, which when pressed with an angular hard object has the same resistance as adjacent healthy wood.

**4** *Loose rot in the centre of the stump*

Loose rot refers to rot with less resistance than adjacent healthy wood.

**5** *Hollow rot in the centre of the stump*

Hollow rot means, as the name implies, that the rot attack resulted in the formation of holes.

In the presence of more than one type of rot, the one with the highest code is indicated. Rot with a diameter of less than 5 mm are classified as "no rot", code "0".

**RÖTDIAMETER**

Diameter of the rot (mm)

Codes: 1-999

If any type of central rot has been specified, the diameter of the rot is measured and registered. A measure is specified, which includes all centred rot, i.e. the measure must include hole, loose and solid rot. The measurement is taken in the same direction as the stump diameter is measured. In the case of non-centred rot, no diameter is specified.

## 10 ABOUT SWEDISH FOREST SOIL INVENTORY and GROUND VEGETATION DESCRIPTION

Chapters 11 and 12 deal with work steps to be performed on volume sample plots in *P<sub>M</sub>-tracts*. These steps are normally performed by the soil surveyor, and the inventory takes place on **one single sub-sample plot** if the sample plot is split. The elements in question are description of *soil condition* and *soil sampling* (i.e. Soil inventory (not included in this translated version), and *ground vegetation description* (included in this translated version).

### Valid land use classes

The land use class must be one of the following for soil inventory and ground vegetation description to be carried out.

|  | (Code) |
|--|--------|
| <i>Productive forest land</i>          | (1)    |
| <i>Natural pasture</i>                 | (2)    |
| <i>Morass</i>                          | (4)    |
| <i>Rock and some other impediments</i> | (5)    |
| <i>Subalpine coniferous woodland</i>   | (6)    |
| <i>High mountains</i>                  | (7)    |

→ *For sample plots on the high mountain land use class that are affected by the phenomena road, railway or plot of land, the relevant sample sub-plots must be deemed failed soil types (in the soil condition description) and AVM (in the ground vegetation description), respectively; thus, no land inventory is ever made on such parts of the sample plots.*

### **Split sample plot**

The sub-plot with any of the land use classes listed above with the *largest vegetation area* (**VY** - radius 5.64 m) must be inventoried.

→ *Note that since 2014, the ground vegetation description is cancelled if  $VY \leq 5 \text{ m}^2$ . There is no such requirement for the soil inventory.*

If, as a result of the division, the *entire VY* ends up on an “invalid” land use class, the ground vegetation description is cancelled, while the soil inventory is carried out *on the largest sub-sample plot* located on valid land use classes.

If several sub-sample plots with a valid land use class have the same **VY**, the sub-sample plot with the lowest sub-sample plot number is inventoried.

If none of the sub-sample plots is located on a valid land use class, no soil inventory or ground vegetation description is carried out.

### **Distribution of the soil surveyor’s tasks in the tracts**

Soil inventory and ground vegetation description are carried out at most on half of the volume sample plots. The execution of the steps is controlled by the position of the plot on the tract and the land use class, figure 10.1.

Region 1-4

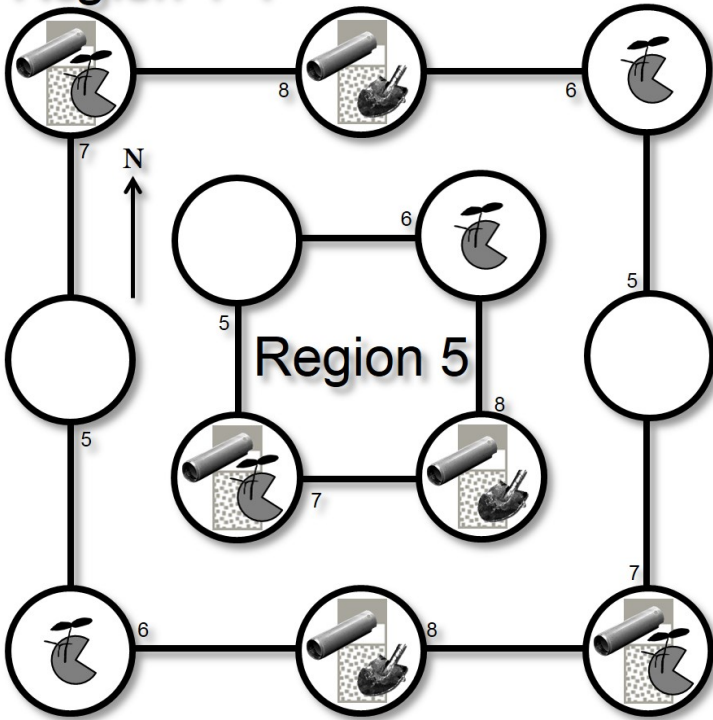

The figures indicate so-called **inventory category**:

- 5 = No soil inventory or ground vegetation description.
- 6 = Ground vegetation description.
- 7 = Soil condition description, humus sampling and ground vegetation description.
- 8 = Soil condition description, humus sampling and mineral soil sampling.

Fig. 10.1 Distribution of the soil surveyor's tasks in the tracts in regions 1-4 and 5, respectively.

Symbol explanation:



= **Soil condition description**  
all valid land use classes, see p. 10:1.



= **Humus sampling**  
all valid land use classes.



= **Mineral soil sampling**  
(so-called deep excavation. Inventory category with code = 8),  
valid land use classes are code 1, 2, 6 and 7.



= **Ground vegetation description**  
all valid land use classes

## 8 SUB-SAMPLE TREES

### 8.1 GENERAL

On permanent sample plots, sub-sample trees from the previous inventory must be re-inventoried and, to a certain extent, new sub-sample trees identified. New sub-sample trees are taken from all coordinated trees thicker than or equal to 40 mm.

On temporary sample plots, sub-sample trees thicker than or equal to 40 mm in breast height are identified. In connection with the caliper measurement, the field computer identifies so-called sub-sample tree candidates. After caliper measurement is completed, the selection of sub-sample trees is initiated by pressing the function key F5 on the field computer. The field computer then identifies a number of these candidates as sub-sample trees. The number of sub-sample trees is determined by land use class, caliper measured base area and surface area of the sample plot. Among trees that have been classified as overgrown in the stem count, sub-sample trees are taken out directly in connection with caliper measurement. From sub-sample trees on temporary sample plots, a bore core is taken at breast height.

New sub-sample trees among coordinated trees on permanent sample plots are automatically removed by the field computer directly in connection with the caliper measurement. Furthermore, the field computer keeps track of old sub-sample trees on permanent plots.

On permanent sample plots, sub-sample trees from the previous inventory have been drawn on the special tree map.

Each removed tree is provided with a special note, on which measurement data is recorded. To avoid confusion, this note should be set up before the next tree is measured. Data is transferred from the note to the field computer when the measurements are completed. When the data has been registered in the field computer, a line is drawn diagonally across the note to indicate that registration has taken place.

On permanent surfaces, the notes are taken down when registration of all trees has taken place. On temporary sample plots, the identity part of the

8.1 Provträd – Allmänt  
8.1 Sub-sample trees - General

sub-sample tree patches is left on the trees. The remaining part is taken from the surface.

The numbering of trees takes place continuously regardless of whether the sample area is divided or not. On permanent sample plots, the sub-sample tree number is the same as the trunk number. On temporary sample plots, the sub-sample tree number is the same as the candidate number, except for overgrown trees which are given numbers from 71.

The different steps and variables in the sub-sample tree description are reported below:

| Step/ variable  | See page |
|---|----------|
| <b>8.2 Registrations for sub-sample trees</b> .....               | 8:8      |
| <b>8.2.1 General sub-sample tree variables</b> .....              | 8:8      |
| Breast height diameter ( <b>DIAMETER</b> ) .....                  | 8:8      |
| Tree species ( <b>TRÄDSLAG</b> ).....                             | 8:9      |
| Length of continuous main stem ( <b>LÖVTYP</b> ) .....            | 8:9      |
| Tree height ( <b>HÖJD</b> ).....                                  | 8:10     |
| Canopy boundary height ( <b>KRONGRÄNS</b> ).....                  | 8:11     |
| Tree class ( <b>TRÄDKLASS</b> ) .....                             | 8:13     |
| Cone count ( <b>KOTTRÄKNING</b> ) .....                           | 8:18     |
| Cones ( <b>KOTTAR</b> ) .....                                     | 8:19     |
| Age in the field? ( <b>ÅLDER I FÄLT?</b> ).....                   | 8:19     |
| Breast height age ( <b>BRHÅLDER</b> ) .....                       | 8:22     |
| <b>8.2.2 Canopy thinning</b> .....                                | 8:23     |
| Should canopy thinning be assessed?<br>( <b>KRONUTGLESNING?</b> ) | 8:23     |
| Observation conditions ( <b>OBSFÖRH</b> ).....                    | 8:26     |
| Canopy thinning ( <b>KRONUTGL</b> ).....                          | 8:27     |
| Distance to stand edge ( <b>KANTAVS</b> ) .....                   | 8:28     |
| <b>8.2.3 Damage to sub-sample trees</b> .....                     | 8:29     |
| <u>Root damage</u> .....  | 8:30     |
| Type of root damage ( <b>SKADTYP</b> ) .....                      | 8:30     |
| Extent of root damage ( <b>OMFATT</b> ).....                      | 8:32     |
| <u>Cambium damage</u> .....                                       | 8:32     |
| Type of cambium damage ( <b>SKADTYP</b> ).....                    | 8:32     |
| Site of resin flow ( <b>LÄGE KÅDA</b> ) .....                     | 8:33     |
| Resin flow status ( <b>STATUS</b> ).....                          | 8:33     |
| Length of resin flow ( <b>LÄNGD KÅDA</b> ) .....                  | 8:34     |
| Extent of rot damage ( <b>OMF RÖTA</b> ).....                     | 8:34     |
| Extent of cambium damage ( <b>OMFATTNING</b> ).....               | 8:35     |
| Length of fissure ( <b>LÄNGD</b> ).....                           | 8:35     |
| Site of damage to cambium ( <b>LÄGE</b> ).....                    | 8:36     |



| Step/ variable   | See page |
|--|----------|
| <u>Stem damage</u> .....   | 8:37     |
| Type of stem damage ( <b>SKADTYP</b> ).....  | 8:37     |
| Site of stem damage ( <b>LÄGE</b> ).....   | 8:37     |
| <u>Canopy damage</u> .....   | 8:38     |
| Type of canopy damage ( <b>SKADTYP</b> ).....                                      | 8:38     |
| Dry top site ( <b>LÄGE</b> ) .....   | 8:38     |
| Extent of canopy damage ( <b>OMFATT</b> ).....                                     | 8:39     |
| <u>Time of damage and cause of damage</u> .....                                    | 8:39     |
| Time of damage ( <b>SKADTID</b> ).....   | 8:39     |
| Cause of damage ( <b>SKADORS</b> ) .....   | 8:41     |
| <b>8.2.4 Hanging Lichen</b> .....  | 8:43     |
| 8.2.4.1 General .....  | 8:43     |
| 8.2.4.2 Variables .....  | 8:45     |
| Is there presence of growing witch’s hair lichen<br>( <b>FINNS GARNLAV?</b> )..... | 8:45     |
| Length of longest witch’s hair lichen trunk<br>( <b>LÄNGD GARNLAV</b> ) .....      | 8:45     |
| Is there presence of growing <i>Usnea</i><br>( <b>FINNS SKÄGGLAV?</b> ) .....      | 8:45     |
| Length of longest <i>Usnea</i> trunk ( <b>LÄNGD SKÄGGLAV</b> )... ..               | 8:45     |
| Is there presence of growing <i>Bryoria</i><br>( <b>FINNS TAGELLAV?</b> ) .....    | 8:46     |
| Length of longest <i>Bryoria</i> trunk ( <b>LÄNGD TAGELLAV</b> )... ..             | 8:46     |
| 8.2.4.3 Main distinguishing characteristics for <i>Usnea</i><br>groups .....       | 8:48     |

## 8.2 REGISTRATIONS FOR SUB-SAMPLE TREES

When the sub-sample tree menu opens, a list of the sub-sample trees present on the plot appears. From the list, select the sub-sample tree that you want to register.

The Sub-sample tree menu is divided into the following five parts:

- General sub-sample tree variables.
- Canopy thinning, available when these assessments are to be made.
- Damage to sub-sample trees.
- *Usnea* inventory, available only for spruce  $\geq 150$  mm in P<sub>M</sub> tracts.

### 8.2.1 GENERAL SUB-SAMPLE TREE VARIABLES

#### DIAMETER

Breast height diameter (mm)

Codes: 0-9999

Diameter is retrieved automatically from the caliper menu.

#### TRÄDSLAG

Tree species are only indicated for *Betula pubescens* and *Betula pendula*. For other tree species, the tree species are automatically retrieved from the caliper menu. The *tree species code* must, however, be stated for all tree species on the sub-sample tree note on temporary sample plots and then written on the bore sleeve.

#### LÖVTYP

Code Length of continuous main stem

1 *Less than 1/3 of the tree height*

2 *1/3 - 2/3 of the tree height*

### 3 *More than 2/3 of the tree height*

For oak and beech with a breast height diameter of  $\geq 150$  mm, the length of the continuous main stem is stated in three classes.

## **HÖJD**

Tree height (dm)

Codes: 13-500

The height is measured as the length of the tree from the ground to the top of the tree (including top shoots). Regarding determining the level of the ground surface, see section 7.2 The height is stated in the nearest dm.

For broken trees without replacement tops, a supplement shall be made for the assessed length of the broken-off part. For broken trees with replacement tops, no supplement is made. For trees with a dry top that have a replacement top, the height to the top of the replacement top is measured. The height measurement is performed with an height gauge or, where appropriate, with a bar. When using a height gauge, Vertex III should primarily be used. In the alternative, Haglöfs electronic height gauge (HEC) is used. The use of height gauges is described in Appendix B1.

## **KRONGRÄNS**

Canopy boundary height (dm)

Codes: 1-500

The canopy boundary height refers to the distance along the trunk from the ground surface to the attachment point for the lowest green branch. However, a single branch that is isolated from the rest of the canopy with at least three dead branch laps is not considered a canopy boundary. In the case of a double stem with a division above breast height, the canopy boundary is measured on the highest trunk. The ground surface is determined in the same way as when measuring height. The canopy limit

8.2.1 Sub-sample trees - Registrations for sub-sample trees  
- General sub-sample tree variables

is stated in the nearest dm (1 dm minimum permissible value).

So-called water shoots are never counted as a branch.

The canopy boundary height is measured with an altimeter or bar.

## TRÄDKLASS

| Code | Tree class         | Code | Tree class               |
|------|--------------------|------|--------------------------|
| 1    | <i>Independent</i> | 5    | <i>Suppressed</i>        |
| 2    | <i>Dominant</i>    | 6    | <i>Undergrowth</i>       |
| 3    | <i>Co-dominant</i> | 7    | <i>Over storey trees</i> |
| 4    | <i>Dominated</i>   |      |                          |

The tree class describes the position of trees in the tree group to which they belong. "Group" means the trees that stand within a circle, around the tree in question, with a radius that is approximately equal to half the stand height of the 20 m surface, but at least 30 dm.

For broken trees without replacement tops, the tree class that corresponds to the height of the tree is stated as unbroken. For broken trees with replacement tops, the tree class that corresponds to the tree's current actual height is stated.

### **1** *Independent*

trees consist of single trees in gaps and the like.

### **2** *Dominant*

trees are the tallest and usually the thickest in the tree group to which they belong.

### **3** *Co-dominant*

trees are slightly lower, have a less developed canopy and are often thinner than the dominant ones.

### **4** *Dominated*

trees are shorter than the co-dominant trees, often have shorter top shoots and usually a small (deformed) canopy.

### 5 *Oppressed*

trees are significantly shorter and thinner than other trees in the group.

### 6 *Undergrowth*

are trees that are significantly younger and lower than the main stand. Significantly younger means at least 50% younger than the youngest trees in the main stand on the sample plot. Significantly lower means that the trees are less than 1/6 of the tallest trees in the stand.

### 7 *Over storey trees*

are trees which are significantly older and usually taller than the main stand on the 20 m surface and which occur in such small numbers that their closeness falls below 0.3. Main stands are the trees that would have determined the maturity class if the maturity class had been set only on the 20 m surface. If the majority of trees on the 20 m surface are thicker than 10 cm, the over storey trees must be at least 50% older than the oldest trees in the main stand on the surface.

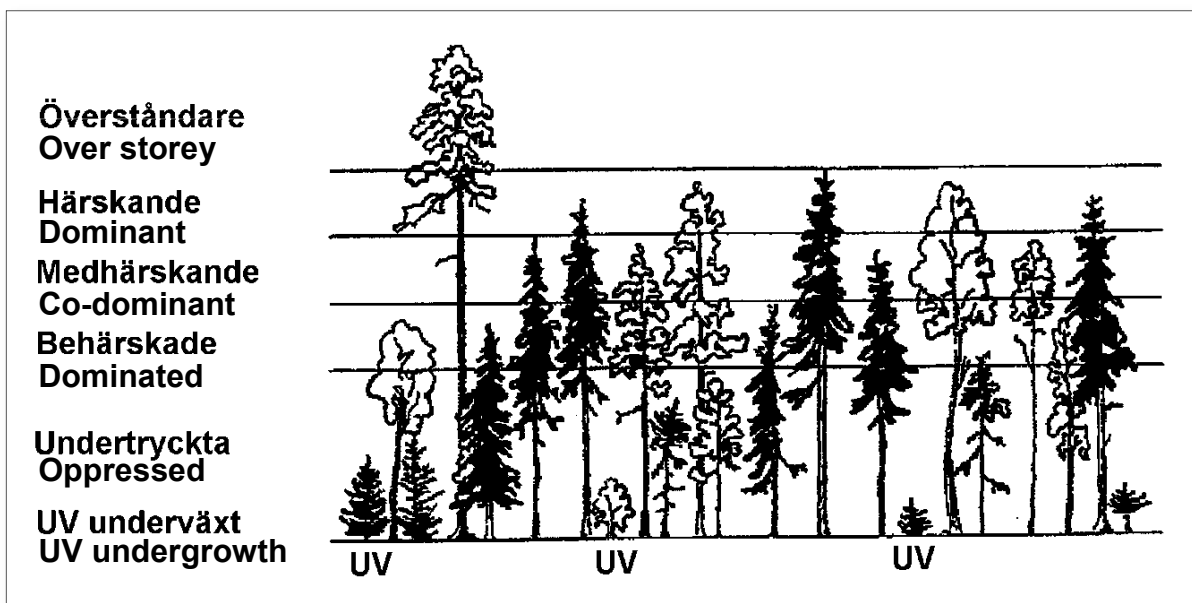

Fig. 8.1 *Tree classes.*

8.2.1 Sub-sample trees - Registrations for sub-sample trees  
- General sub-sample tree variables

In addition, if the relative position of the trees in the group is not sufficient for classification, their heights may be indicative as follows:

- *Dominant*  $\geq 5/6$  of the height of the tallest trees
- *Co-dominant*  $4/6 - 5/6$  - "-
- *Dominated*  $3/6 - 4/6$  - "-
- *Oppressed*  $\leq 3/6$  - "-
- *Undergrowth*  $\leq 1/6$  - "-

8.2.1 Sub-sample trees - Registrations for sub-sample trees  
- General sub-sample tree variables

### **KOTTRÄKNING?**

Code Should cones be counted?

0 No  
1 Yes

Cone occurrence is stated for sub-sample trees of *pine* and *spruce*, 100 dm and higher on *productive forest land*. Cones that ripen next autumn/winter are registered. In the spring and early summer, the female flowers are counted on *spruce*. The counting is done with the help of binoculars on the half of the canopy that is best seen. In this case, you must not count cones on the far half of the canopy. The number of cones on half the canopy is registered.

If the observation conditions are poor (poor light, poorly developed cones (pine cones are often difficult to distinguish in early summer), obstructed view, difficulties in distinguishing different vintages of cones), cone counting is not carried out.

### **KOTTAR**

Number of cones

Codes: 0-401

If the number of cones exceeds 400, the code "401" is registered

### **ÅLDER I FÄLT?**

Code Has the breast height age been determined on site?

0 No, boring core or top shoot has not been counted  
1 Yes, breast height age determined on site

The breast height age of the sub-sample tree is stated for trees  $\geq 40$  mm on *productive forest land*. On temporary surfaces, the age is determined based on a boring core or top shoot count. On permanent surfaces, the age is determined by top shoot counting when possible. For decayed trees with incomplete cores, for deciduous trees of harder tree species, which cannot be bored to the marrow, and in other cases where the age cannot be determined on site with the help of the core and top shoot count cannot

## 8.2.1 Sub-sample trees - Registrations for sub-sample trees - General sub-sample tree variables

be registered "No". The age determination does not include the current year's annual ring or top shoot.

Bore-core is extracted from all sub-sample trees on temporary sample plots. The bore is held perpendicular to the longitudinal direction of the tree and aimed to reach the marrow. On trees smaller than 15 cm, the bore core must touch the marrow. On thicker trees, do not miss the marrow by more than 2 cm, which can be checked with a rhodoid plate. The requirement to get close to the marrow is higher the narrower the annual rings are in the vicinity of the marrow. The bore is held in the direction of the sample plot radius and, unless practical reasons indicate otherwise, with the shaft aimed at the centre of the plot.

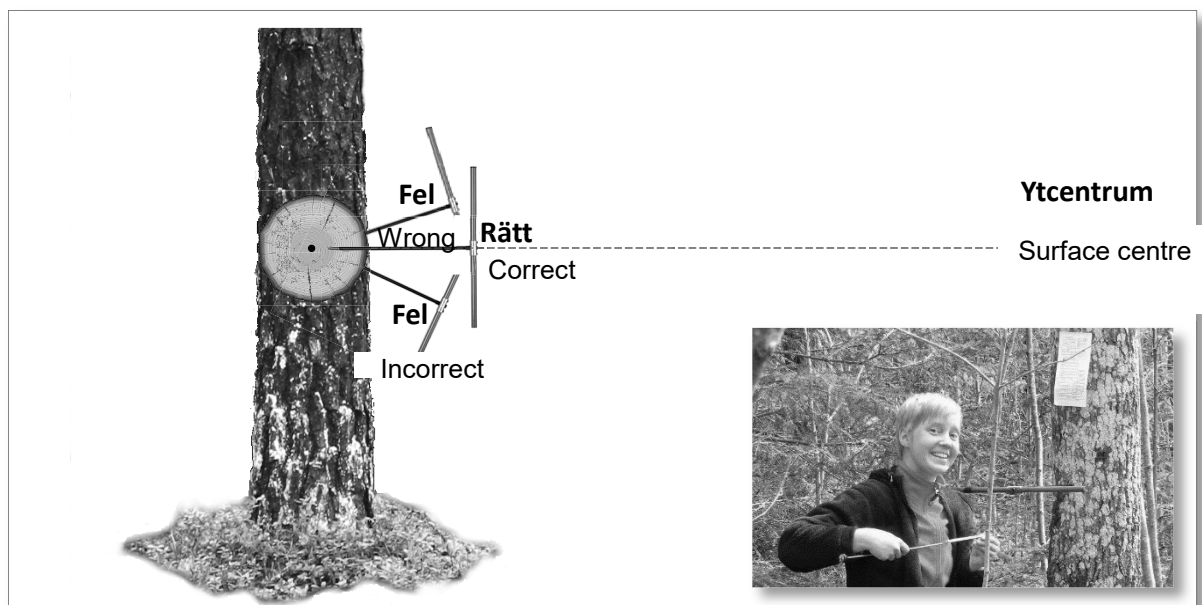

**Fig. 8.2** *Boring of trees.*

Bore supports must always be used. Only bores with 5.0 mm and thicker drill steel may be used. The boring core must reach at least 30 mm beyond the marrow. Twigs must not be present in the core. If the bark has disappeared from the boring core, the core may only be submitted if it is absolutely certain that no annual ring accompanied the bark. The end surface of the last annual ring must be marked with a ring in the absence of bark.



8.2.1 Sub-sample trees - Registrations for sub-sample trees  
- General sub-sample tree variables

Boring cores that have been broken off but are otherwise faultless may be submitted if the end surfaces of the fracture are marked with an x. However, the boring core may only be broken in one place, and the outermost 2 cm must be whole. All marking on the core is done with aniline pen.

**BRHÅLDER**

Breast height age, years

Codes: 1-999

## 8.2.2 CANOPY DEFOLIATION

### KRONUTGLESNING?

|      |  |
|------|--|
| Code | Should canopy thinning be assessed?        |
| 0    | No, canopy thinning should not be assessed |
| 1    | Yes, canopy thinning should be assessed    |

Canopy thinning is assessed on *productive forest land* for sub-sample trees of *spruce* and *pine* in the tree classes *dominant*, *co-dominant*, *independent* and *over storey tree*. The assessment refers to the thinning of the canopy compared with a full coniferous ornament intended for the tree, under current conditions, taking into account genetic variation, site conditions and stand structure.

The assessment shall refer to the upper half of the canopy for spruce and for pine the upper two thirds of the canopy. When assessing what a canopy is, parts below the green canopy must also be included if the fine twig still remains.

Note that canopy thinning is not only a loss of conifers but also includes gaps in the branching due to loss of fine twigs and branches. Reduced needle volume as a consequence of reduced needle length is also included, however, taking into account current conditions.

Assessed canopy thinning shall refer to all thinning, regardless of the reason for it, with the following exceptions. The assessment disregards the parts of the canopy that are affected by congestion, mechanical damage (e.g. fractures caused by wind), self-shading and gaps that have arisen after a normal age loss of conifers or shoots. Furthermore, top fractures and older dry tops/branches are disregarded (see definition below). Male flowering in pine can give a thinned canopy, especially in the lower part, but should not be considered as canopy thinning. Yellow or discoloured needles that remain do not count as canopy thinning. Note, however, that dead (red/brown) needles count as thinning. The assessment is made in 1% classes and refers to class centres.

Spruce: The thinning pattern is slightly different for different canopy types,

8.2.2 Sample trees - Registrations for sub-sample trees.  
- Canopy thinning.

so the canopy type must be considered. The canopy thinning of spruce often appears as an even thinning a bit below the top and down.

Pine: The thinning of pine does not follow the same pattern as that of spruce, but often occurs more irregularly and often in individual, thicker branches. With strong canopy thinning, the canopy gets a more even thinning. Male flowering can give a thinned canopy, especially in the lower part, but should not be considered as a canopy thinning.

For dry tops and dry branches, it applies that if most of the fine twig has fallen off, these should not be included in the canopy thinning. If, on the other hand, most of the fine twig remains, the dry part must be included in the assessment of the canopy thinning. Note that this also applies to *peridermium* attacks.

If more than half of the original canopy (calculated in length) is missing due to top / trunk break (without replacement top) or if a dry top that is to be disregarded as above comprises more than half the canopy, no assessment is made of the canopy thinning, without the code No stated . Otherwise, the remaining green part of the canopy is assessed.

## **OBSFÖRH**

| Code | Observation conditions   |
|------|--|
| 1    | <i>Good or normal conditions.</i>  |
| 2    | <i>Slightly impaired.</i><br>Light rain and / or wind.   |
| 3    | <i>Very poor.</i><br>Rain, fog and/or strong winds and very difficult to see the trees due to obstructed view. |

The variable is registered for the trees where canopy thinning is to be assessed (pine and spruce in the tree classes "1", "2", "3" and "7") and intends to give a rough picture of the observation conditions.

## **KRONUTGL**

8.2.2 Sample trees - Registrations for sub-sample trees.  
- Canopy thinning.

Canopy thinning, %

Codes: 0-100

**KANTAVS**

| Code | Distance to stand edge (m)               |
|------|--|
| 00   | <i>Trees in the outermost stand edge</i> |
| 05   | $\leq 5.0$                               |
| 10   | 5.1 - 10.0                               |
| 15   | 10.1 - 15.0                              |
| 20   | 15.1 - 20.0                              |
| 21   | $> 20.0$                                 |

For the sub-sample trees where canopy thinning is specified, the distance from the sub-sample tree to the nearest hatch or edge towards the lower stands must also be registered. A gap means an opening whose diameter is greater than the height of the stand, but at least 15 m.

Lower stand means a stand where the average height is lower than 2/3 of the average height in the described stand.

8.2.3 Provträd – Registreringar för provträd.

– Skador på provträd.

8.2.3 Sub-sample trees - Registrations for sub-sample trees

– Damage to sub-sample trees.

### **8.2.3 DAMAGE TO SUB-SAMPLE TREE**

Damage to sub-sample trees is divided into the following four main groups:

- Root damage.
- Cambium damage.
- Stem damage.
- Canopy damage.

For each of these main groups, a maximum of three different items of damage can be registered. In the event of more than three items of damage, the most serious items are registered.

For each damage, the type of damage is registered and, depending on the type of damage, in some cases the location or extent, time and cause of the damage.

If a certain type of damage occurs with different causes or location/extent, each combination is registered as one item. Likewise if a certain cause of damage has given rise to several types of damage. Fungal damage that has given rise to both dry top and cambium damage is, however, only registered as dry top. However, mechanical cambium damage that occurred at the same time is always registered as a single item and the total extent is stated. Furthermore, resin flow is registered only once.

The overview for the sub-sample tree's registrations contains the heading "damage". If there is no damage, press enter on the heading and select "no damage".

#### **Root damage**

#### **SKADTYP**

| Code | Type of root damage                                      |
|------|--|
| 41   | <i>Jerked root</i>                                       |
| 42   | <i>External root damage</i>                              |
| 43   | <i>Twisted roots or other equivalent planting damage</i> |

8.2.3 Provträd – Registreringar för provträd.  
– Skador på provträd.  
8.2.3 Sub-sample trees - Registrations for sub-sample trees  
– Damage to sub-sample trees.

*Jerked root* means trees that are leaning as a result of the root system being disturbed.

*External root damage* refers to damage to roots within 2 m of the stem base and is registered if there is a broken or crushed root with a diameter of at least 1 cm or if there are roots with cambium damage, where individual damage exceeds 4 cm<sup>2</sup>.

## OMFATT

| Code | Extent of root damage |
|------|-----------------------|
| 1    | <i>Minor</i>          |
| 2    | <i>Major</i>          |

Indicated only for *external root damage*. Major extent refers to at least 6 damaged roots or cambium damage that in total exceeds 20 cm<sup>2</sup>.

## Cambium damage

### SKADTYP

| Code | Type of cambium damage  |
|------|---|
| 11   | <i>Mechanical damage or other cause other than fungus or insect. Nails and the like in the wood are also included here.</i> |
| 12   | <i>Fungus</i>   |
| 13   | <i>Insect</i>   |
| 14   | <i>Resin flow (spruce only)</i>   |
| 16   | <i>Fissure</i>  |
| 18   | <i>Necrosis (spruce only)</i>   |
| 31   | <i>Rot damage</i>   |

Only cambium damage (with the exception of fungi and insects) that affects the bottom 10 m of the tree trunk is included.

- 8.2.3 Provträd – Registreringar för provträd.  
– Skador på provträd.  
8.2.3 Sub-sample trees - Registrations for sub-sample trees  
– Damage to sub-sample trees.

## LÄGE KÅDA

| Code | Site of resin flow   |
|------|--|
| 1    | <i>Only below breast height</i>                                  |
| 2    | <i>Above breast height or both above and below breast height</i> |

Specified for *resin flow*. Refers to the position of the resin flows in the tree.

## STATUS

| Code | Status of resin flow                    |
|------|---|
| 00   | <i>Transparent or runny resin</i>       |
| 01   | <i>White or yellow-orange resin</i>     |
| 13   | <i>Both transparent and white resin</i> |

Specified for *resin flow*. Refers to the condition of the resin flows (active/inactive).

## LÄNGD KÅDA

| Code | Length of resin flow (m) |
|------|--------------------------|
| 2    | <i>1.0-2.0</i>           |
| 5    | <i>2.1-5.0</i>           |
| 6    | <i>&gt; 5.0</i>          |

Specified for *resin flow*. Refers to the total length of resin flows.

## OMF RÖTA

Extent of rot damage

Codes: 1-5

Indicated for *rot damage*. Scope refers to one-fifth of the radius of the boring core. Upper class limit is registered.

8.2.3 Provträd – Registreringar för provträd.  
– Skador på provträd.  
8.2.3 Sub-sample trees - Registrations for sub-sample trees  
– Damage to sub-sample trees.

## OMFATTNING

Extent of cambium damage

Codes: 1-5

*Indicated for cambium damage mechanical damage or other ("11") or necrosis ("18").* Scope is given as one-fifth of the circumference of the tree. Upper class limit is registered. For nails or other metal objects in the tree, set the code "2".

## LÄNGD

| Code | Length for fissure (dm) |
|------|-------------------------|
| 05   | 2-5                     |
| 10   | 6-10                    |
| 11   | > 10                    |

Indicated for *cambium fissure* damage. Refers to the length of the fissure. In the case of several fissures with the same cause and time, the total length of the fissures is stated.

## LÄGE

Location for cambium damage (m)

Codes: 0-30

Indicated for cambium damage *fungus* and cambium damage *insect*. Refers to the distance, to the nearest meter, from the ground to the lower part of the damage.



- 8.2.3 Provträd – Registreringar för provträd.  
– Skador på provträd.  
8.2.3 Sub-sample trees - Registrations for sub-sample trees  
– Damage to sub-sample trees.

## **Stem damage**

### **SKADTYP**

| Code | Type of stem damage  |
|------|--|
| 20   | <i>Stem fracture or dry top with replacement top below 1.3 m</i> |
| 21   | <i>Stem fracture or dry top with replacement top over 1.3 m</i>  |
| 22   | <i>Stem fracture without replacement top</i>                     |
| 24   | <i>Permanently bent</i>  |
| 25   | <i>Sprout branch below 1.3 m</i>                                 |
| 26   | <i>Sprout branch over 1.3 m</i>                                  |
| 27   | <i>Double stem under 1.3 m</i>                                   |
| 28   | <i>Double stem/double top over 1.3 m</i>                         |

### **LÄGE**

Location of stem damage (m)

|        |  |
|--------|--|
| Codes: | 0-1 (damage type "20", "25" and "27")  |
|        | 1-10 (damage type "21", "26" and "28") |
|        | 0-30 (damage type "22")                |

Refers to the distance, to the nearest meter, from the ground to the lower part of the damage.

Not specified for permanent downward bend.

## **Canopy damage**

### **SKADTYP**

| Code | Type of canopy damage                                 |
|------|---|
| 23   | <i>Dry top</i>  |
| 51   | <i>Needle/leaf loss (mechanical damage or fungus)</i> |
| 52   | <i>Discoloration of needles/leaves</i>                |

8.2.3 Provträd – Registreringar för provträd.  
– Skador på provträd.  
8.2.3 Sub-sample trees - Registrations for sub-sample trees  
– Damage to sub-sample trees.

## LÄGE

Site of dry top (m)

Codes: 1-30

Set for *dry top*. Refers to the distance, to the nearest meter, from the ground to the lower part of the damage.

## OMFATT

| Code | Extent of canopy damage (%)                     |
|------|---|
| 25   | 1-25 (refers only to damage type "23", dry top) |
| 60   | 26-60   |
| 61   | > 60  |

## Time of damage and cause of damage

### SKADTID

| Code | Time of damage                                      |
|------|---|
| 00   | <i>This season</i>                                  |
| 01   | <i>Last season</i>                                  |
| 02   | <i>Season 2 or earlier</i>                          |
| 13   | <i>Several seasons including the current season</i> |

For damage types "14", "25/26", "27/28", "31" and "43", the time of damage is not specified.

8.2.3 Provträd – Registreringar för provträd.

– Skador på provträd.

8.2.3 Sub-sample trees - Registrations for sub-sample trees

– Damage to sub-sample trees.

| Code | Cause of damage   |   |
|------|-------------------|---|
| 11   | <b>Climate</b>    | <i>Wind and / or snow</i>                     |
| 12   |                   | <i>Frost</i>                                  |
| 15   |                   | <i>Another climate issue</i>                  |
| 21   | <b>Human</b>      | <i>Forestry</i>                               |
| 25   |                   | <i>Other</i>                                  |
| 26   |                   | <i>Nature conservation</i>                    |
| 31   | <b>Vertebrate</b> | <i>Moose</i>                                  |
| 36   |                   | <i>Reindeer</i>                               |
| 37   |                   | <i>Deer</i>                                   |
| 38   |                   | <i>Wild boar</i>                              |
| 32   |                   | <i>Other larger mammals</i>                   |
| 33   |                   | <i>Beaver</i>                                 |
| 34   |                   | <i>Other rodents</i>                          |
| 35   |                   | <i>Other vertebrates</i>                      |
| 41   | <b>Insect</b>     | <i>Tomicus piniperda</i>                      |
| 42   |                   | <i>Spruce bark beetle</i>                     |
| 43   |                   | <i>Other bark beetle</i>                      |
| 44   |                   | <i>Needle or leaf-eating insect</i>           |
| 45   |                   | <i>Another insect</i>                         |
| 51   | <b>Fungus</b>     | <i>Cronartium flaccidum, Peridermium pini</i> |
| 52   |                   | <i>Rot fungus or Nectria galligena</i>        |
| 53   |                   | <i>Gremmeniella</i>                           |
| 54   |                   | <i>Lophodermium piceae</i>                    |
| 56   |                   | <i>Uredinales</i>                             |
| 57   |                   | <i>Melampsora pinitorqu</i>                   |
| 55   |                   | <i>Other fungus</i>                           |
| 61   | <b>Whipping</b>   | <i>Whipping</i>                               |
| 71   | <b>Fire</b>       | <i>Fire</i>                                   |
| 91   | <b>Other</b>      | <i>Other</i>                                  |

## 8.2.4 INVENTORY OF ALECTORIA, USNEA AND BRYORIA

### 8.2.4.1 General

Hanging lichens are inventoried on sub-sample trees of spruce,  $\geq 150$  mm, in  $P_M$  tracts. The inventory includes the three "lichen groups" *Alectoria sarmentosa*, *Usnea spp.* and *Bryoria spp.*

For the lichen/lichen groups, the entire canopy below the height of 5 m is inventoried, i.e. also branches that may protrude outside the boundary line of the sample plot. For each lichen/lichen group, the *length of the longest specimen is measured*. In the absence of branches, lichen trunks are assessed/measured of each species/species group that grows on the trunk instead. The length is registered in 1 cm classes, the upper class limit is registered, i.e. 0-1 cm is registered with the code "1". Lengths  $> 98$  cm are registered with the code "99".

Code Length of longest hanging lichen (cm, "top" classes).

|     |         |      |
|-----|---------|------|
| 1   | > 0 --  | ≤ 1  |
| 2   | > 1 --  | ≤ 2  |
| ... | ...     | ...  |
| 98  | > 97 -- | ≤ 98 |
| 99  | > 98    |      |

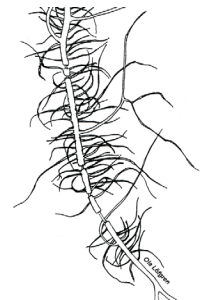

→ *Registered value shall refer to the actual length of the longest individual item; If the lichens are strongly tangled and twisted around twigs or around each other, a judicious estimate of actual length must be made. Lichens that lie so loose that they can easily fall down from the tree are not taken into account!*

### 8.2.4.3 Sub-sample trees - Registrations for sub-sample trees

- Hanging lichen inventory - The most important distinguishing characteristics for the hanging lichen groups

## 8.2.4.2 Variables

---

### IS THERE PRESENCE OF GROWING WITCH'S HAIR LICHEN?

Code Is there presence of growing witch's hair lichens up to 5 meters high in the tree?

0      *No*  
1      *Yes*

### LENGTH WITCH'S HAIR LICHEN

Code Length of longest witch's hair lichen trunk in the tree (cm)

1-99

### IS THERE *USNEA*?

Code Is there presence of growing *Usnea* up to 5 meters high in the tree?

0      *No*  
1      *Yes*

### LENGTH *USNEA*

Code Length of longest *Usnea* trunk in the tree (cm)

1-99

8.2.4.3 Sub-sample trees - Registrations for sub-sample trees  
- Hanging lichen inventory - The most important distinguishing characteristics for the hanging lichen groups

**IS THERE *BRYORIA* ?**

Code Are there growing *Bryoria* lichens up to 5 meters high in the tree?

0      **No**  
1      **Yes**

**LENGTH *BRYORIA***

Code Length of longest *Bryoria* in the tree (cm)

1-99

8.2.4.3 Sub-sample trees - Registrations for sub-sample trees

- Hanging lichen inventory - The most important distinguishing characteristics for the hanging lichen groups

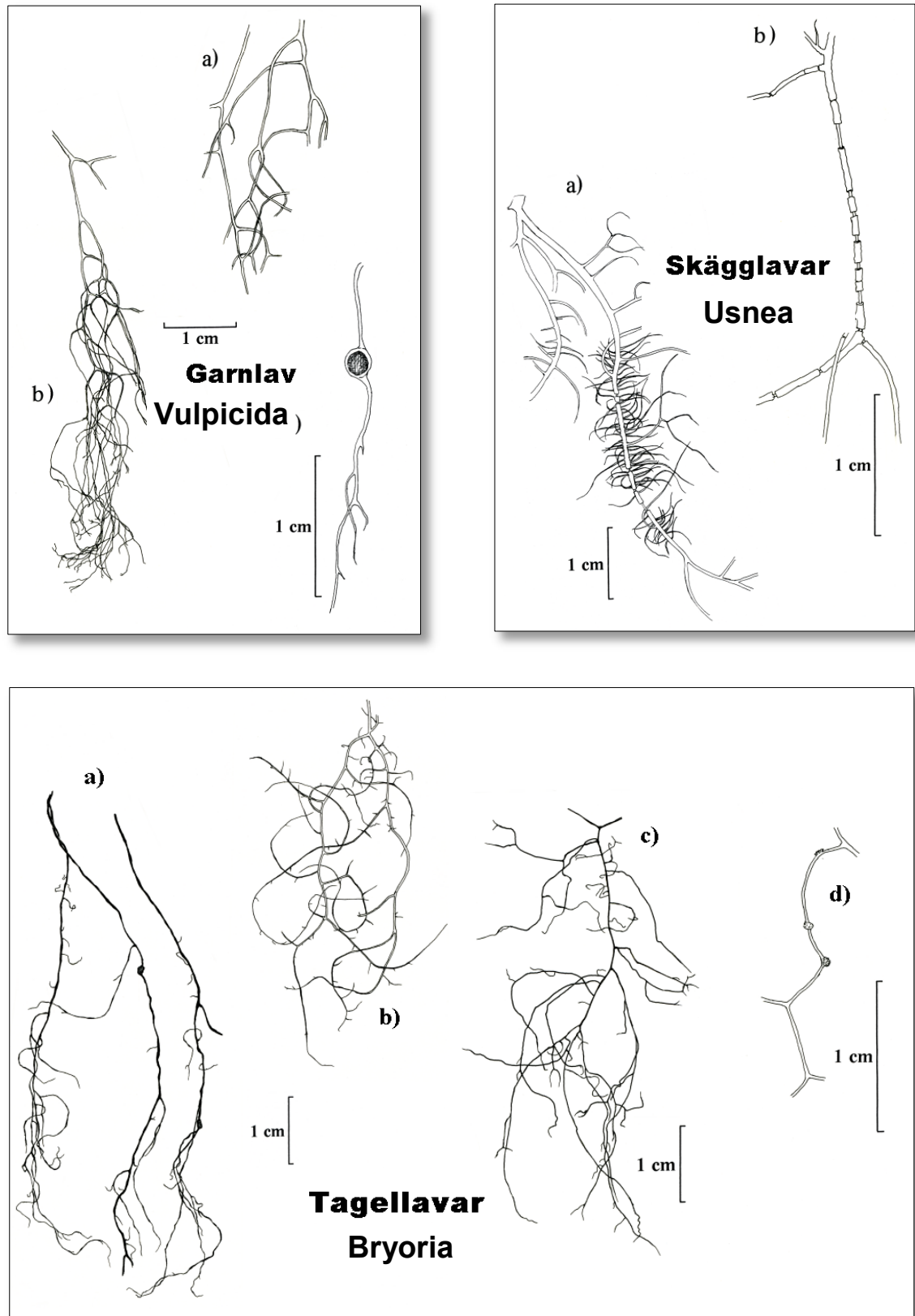

Fig. 8.4 Included species/species groups in the hanging lichen inventory

## 12 GROUND VEGETATION DESCRIPTION ON 100 M<sup>2</sup> SURFACE AREA

### 12.1 GENERAL

The ground vegetation is inventoried on the volume sample plots in the **P<sub>M</sub>**-tracts. The vegetation is inventoried on a circular area with the same centre as the sample plot and with a radius of 5.64 m - called the vegetation area "veg area" or VY. As of 2014, if the sample plot is divided in such a way that the veg area is  $\leq 5 \text{ m}^2$  then the ground vegetation description is cancelled. The inventory is cancelled even if the observed vegetation surface area (BVY) is 0 m<sup>2</sup>.

On some of the sample plots in the tract (figure 12.1 below) with *valid land use classes* (see page 10: 1), the presence of the species list's 268 species /species groups is registered, as well as cover\_of 71 species/species groups (incl. BSA and FSAK). For selection of sub-sample plot - see chapter 10.

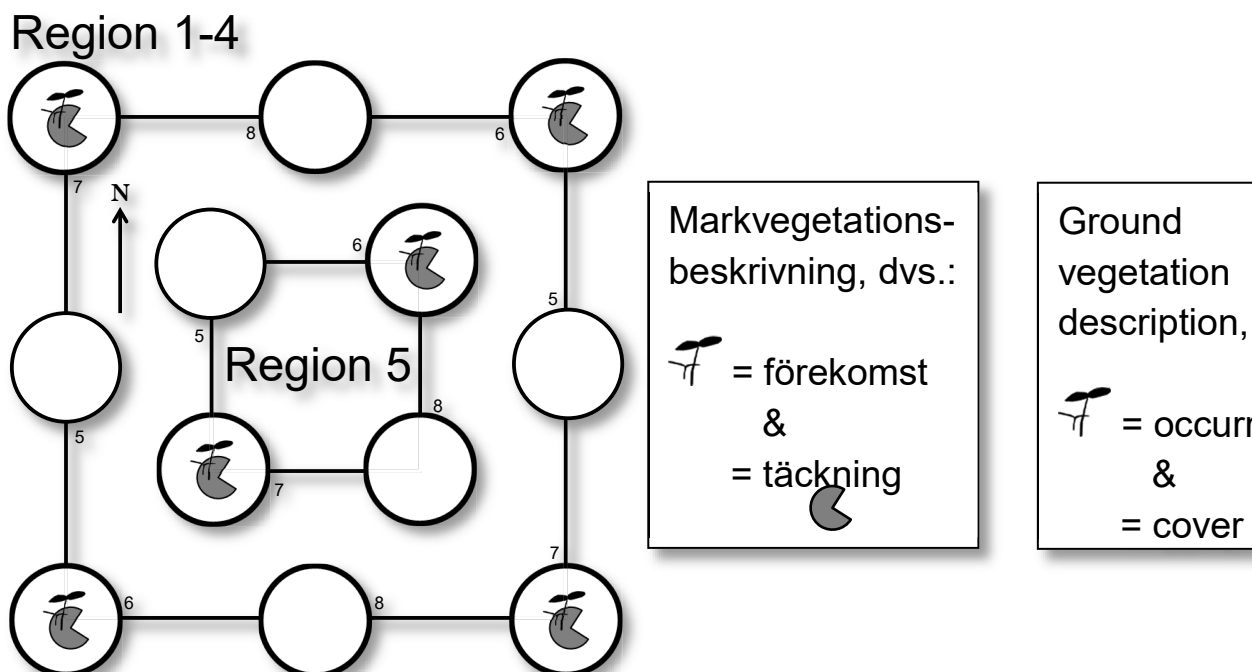

**Fig.12.1.** Ground vegetation description on areas with land use classes: Productive Forest Land, Natural Pastures, Morass, Rock and certain other impediments, Subalpine coniferous woodland or High mountains.



---

| <b>Step/Variable</b>  | <b>See page</b> |
|---|-----------------|
| <b>12.2 Registration of general ground vegetation description</b> ..... | 12:5            |
| Name of the ground vegetation surveyor ( <b>Surveyor</b> )              | 12:6            |
| Vegetation area ( <b>VY</b> ) .....                                     | 12:7            |
| Deviating ground area ( <b>AVM</b> ) .....                              | 12:7            |
| Ground-treated area ( <b>MBA</b> ) .....                                | 12:10           |
| Observed vegetation surface area ( <b>BVY</b> ).....                    | 12:11           |
| <b>12.3 Registration of occurrence</b> .....                            | 12:13           |
| <b>12.3.1 General</b> .....   | 12:13           |
| <b>12.3.2 List of species in systematic order</b> .....                 | 12:22           |
| <b>12.4 Assessment of cover ratio</b> .....                             | 12:32           |
| <b>12.4.1 General</b> .....   | 12:32           |
| <b>12.4.2 Assessment of cover</b> .....                                 | 12:34           |
| <b>12.4.3 List of species for registration of cover</b> .....           |                 |
| <i>(including BSA and FSAK)</i>   | 12:36           |
| <b>12.5 Assessment of reindeer lichen height (RENLAVSHÖJD)</b> .....    | 12:47           |

---

## 12.2 REGISTRATION OF GENERAL GROUND VEGETATION DESCRIPTION

A ground vegetation description is carried out only on ground which is deemed representative of the site with regard to the soil's ability to deliver plant nutrients from an intact humus layer or otherwise "undisturbed" ground surface, which is the so-called observed vegetation area (BVY). Deviating ground (AVM) and ground treated area (MBA) are excluded.

All area information in connection with the ground vegetation description (i.e. VY, AVM, MBA, BVY, BSA, FSAK and species/species group cover) are given in m<sup>2</sup> classes ("top" classes) as follows:

| <b>Cover for VY, AVM, MBA, BVY, BSA and FSAK</b> |                        | <b>Cover for species/species groups</b> |                        |
|--|------------------------|---|------------------------|
| Code   | Area (m <sup>2</sup> ) | Code                                    | Area (m <sup>2</sup> ) |
| 0  | 0                      | 0                                       | > 0 -- ≤ 0.1           |
| 1  | > 0 -- ≤ 1             | 1                                       | > 0.1 -- ≤ 1           |
| 2  | > 1 -- ≤ 2             | 2                                       | > 1 -- ≤ 2             |
| 3  | > 2 -- ≤ 3             | 3                                       | > 2 -- ≤ 3             |
| ...  | ...                    | ...                                     | ...                    |
| 99   | > 98 -- ≤ 99           | 99                                      | > 98 -- ≤ 99           |
| 100  | > 99 -- ≤ 100          | 100                                     | > 99 -- ≤ 100          |

→ The area of 0 m<sup>2</sup> is not available for species/species groups.

**INVENTERARE** [Vegetation menu , submenu General directions]

The name of the ground vegetation surveyor must be provided.

**VY** [Vegetation menu , submenu General directions]

The *area of the vegetation plot* is circular and concentric with the sample plot but with a radius of 5.64 metres. If the sample plot is divided and the dividing lines cut across the veg-plot, each such part is called a "subveg-plot". The area of the veg-plot/subveg-plot (VY) is given by S&M based on

## 12.2 Soil vegetation description - Registration of general soil vegetation description.

the division coordinates. If the veg-plot is undivided, the area = 100 m<sup>2</sup>.

→ *Always place marker sticks or similar on the periphery of the veg-plot to facilitate inventory. In the case of a divided sample plot, it is necessary to mark the dividing line in the terrain.*

### **AVM**

[Vegetation menu , submenu General directions]

In the variable AVM, the *area of deviating ground* within the veg-plot/subveg-plot is registered.

#### Definition:

Deviating ground are those parts where the soil surface is (unintentionally) damaged or where the ground locally for other reasons is strongly distinctive with regard to the plants' germination conditions, competitiveness or growth.

#### Examples of such parts are:

- Paths and roadsides.
- Watercourses and permanent bodies of water.
- Ditches and ditch edges.
- Tree bases, stumps, flames, root rollers and dense accumulations of tree branches (piles of branches/sticks).
- Surface roots and raised ground that tightly encloses the base of tree trunks and stumps.
- Surface blocks with a diameter greater than 50 cm (see definition in section 11.2).
- Patchy dense accumulations of smaller surface blocks (diameter 20-50 cm).
- Ground damaged by driving.

## 12.2 Soil vegetation description - Registration of general soil vegetation description.

Please note:

- *If **field vegetation layer species** have taken root within deviating parts, with a species composition that no longer differs significantly from the vegetation within untouched parts, the parts are no longer deemed deviating ground, even if contours of a previous disturbance remain in the ground surface.*
- *Bedrock (see section 11.2 under “bedrock surface”), pastures where domestic livestock has trampled the ground surface, as well as tuft formations and mires on morass are not deemed deviating ground.*
- *Wild boar brawn is not AVM.*
- *Surface blocks with a diameter greater than 20 cm that have a cover of more than 50 % of VY are not deemed deviating ground.*

### **MBA**

[Vegetation menu , submenu General directions]

In the variable MBA, the *scarified-treated area* is registered within the veg-plot/subveg-plot.

#### Definition:

Scarification-treated areas are areas that have been affected by *soil scarification* in the form of soil preparation or slash and burn or that have been exposed to forest fires.

#### Examples of scarified areas are:

- Ridges (soil in piles or strings).
- Pits and furrows where the mineral soil has been exposed.
- Soil that is still soot-stained by slashing and burning or forest fires.
- Parts affected by topsoil or peat extraction.

Note:

- *If **field vegetation layer species** have taken root within the soil-treated areas, with a species composition that no longer differs significantly from the vegetation within untouched areas, the areas are no longer deemed soil-treated, even if the contours of the soil*

## 12.2 Soil vegetation description - Registration of general soil vegetation description.

*treatment remain in the soil surface.*

**BVY** [Vegetation menu , submenu General directions]

### Definition:

*Observed vegetation surface area* is the area within the veg-plot/subveg-plot that is judged to be representative of the site with regard to the soil's ability to deliver plant nutrients from an intact humus layer or otherwise "undisturbed" soil surface.

BVY is calculated as follows:

$$BVY = VY - (AVM + MBA)$$

The calculation is made automatically in S&M after the AVM and MBA have been registered.

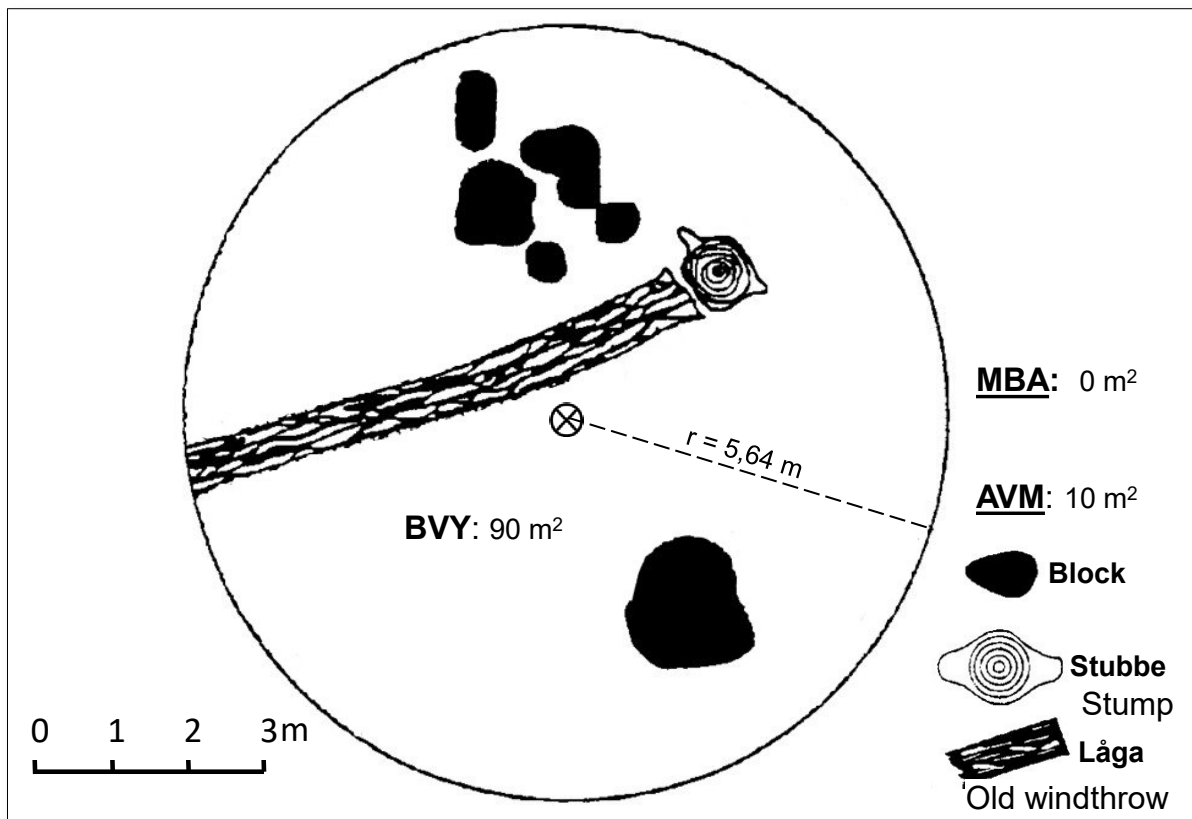

**Fig. 12.2.1** Example of observed vegetation surface area (BVY) on an undivided veg-plot.



## 12.3 REGISTRATION OF OCCURRENCE



### 12.3.1 GENERAL

[Vegetation menu, Occurrence submenu]

Indication of species occurrence refers to the conditions during the current year's entire vegetation period, i.e. plants that have withered during the vegetation period must be registered.

The search for species is difficult early in the season, when the plants are not yet fully developed. In such cases, the withered stems of the previous year's perennial plants should be observed (e.g. *Pteridium aquilinum* and *Molinia caerulea*). In this assessment, the lateness of each species during the vegetation period should be considered.

Even towards the end of the field season, species identification can be difficult. However, it is an advantage to have followed the development of the species during the earlier part of the vegetation period.

Some species can only be identified during part of the vegetation period (e.g. spring onions, *Corydalis* species).

With one exception, species that grow on deviating ground (AVM) or ground-treated areas (MBA) should not be included in the vegetation description. It is thus of the utmost importance that the so-called observed surface area (BVY) is defined before the species search begins.

→ *Species with a tree base classified as AVM are exempted from this rule.*

The species/groups in the list are defined in detail in the compendium **RIS species handbook** - *definitions for the species lists for the ground vegetation inventory*.

The systematically compiled species list is divided into the three main sections, bottom, field and shrub & tree layers. The three main sections are in turn divided into kinship-oriented groups. In the systematically compiled list, the species/species groups are listed in the same order as in **Den nordiska floran**, Mossberg, Stenberg & Ericsson, 1992. Lichen are listed in the order set out in **Lavar**, Moberg & Holmåsen, 1990 follows and bryophyte in the order set out in **Mossor**, Hallingbäck & Holmåsen, 1991. The same order is also found in S&M.

→ *Note that newer flora (e.g. Nordens flora, Mossberg & Stenberg, 2018) has the species arranged in a different order - according to generally accepted international standards.*

The following rules apply to the registration of species/species groups:

Bottom layer and field vegetation layer:

If the plant is projected vertically on the ground surface, the shadow of any part of the above-ground parts of the plant must fall within the veg-plot/subveg-plot to be observed.

Shrub & tree layers (two cases):

1. Individuals higher than 1.3 m are observed if the germination point of the seed is deemed to be within the veg-plot/subveg-plot.

→ Dead trees/shrubs are not included.

2. For other individuals, the same rule applies as for bottom layers and field vegetation layers.



12.3.2 Soil vegetation description - Registration of occurrence  
List of species in systematic order

Please note that:

- *Group-/(departmental) affiliation is completely fixed to the species and does not depend on the stage of development; i.e. even a seedling/annual plant of spruce belongs to the shrub & tree layer.*
- *Hybrids are transferred to one of the parent species - to the parent species to which the hybrid is most similar.*
- *In some cases it may be impossible to determine the species correctly and there is hesitation between two closely related species (species groups) included on the list - in such cases the following rules apply:*

1. In case of doubt between the following species pairs, the underlined species should be registered (i.e. strive to keep the non-underlined species clean of uncertain observations):

*Melampyrum sylvaticum/Melampyrum pratense, Anemone ranunculoides/Anemone nemorosa, Rubus arcticus/Rubus saxatilis, Geum urbanum/Geum rivale L., Trichophorum alpinum/Trichophorum cespitosum, Betula pendula/Betula pubescens, Equisetum pratense/Equisetum arvense and Lysimachia vulgaris/Lysimachia thyrsiflora.*

2. If there is uncertainty between an individual species or a group of species, the individual species must be kept free.
  3. In case of doubt between two individual species included on the list, the uncertain observation must be registered on the species that is more common (across Sweden as a whole).
- *It is very important to consider the boundary between the field vegetation layer and the shrub & tree layer, so that species within the latter are not included in the field vegetation layer cover (the groups "**upper field vegetation layer**" and "**upper deciduous tree o-b**" must not be mixed up). The following examples of species within each layer are worth noting in particular:*

Field vegetation layer:

- *Vaccinium uliginosum ssp. uliginosum/alpinum*
- *Ledum palustre*, syn. *Rhododendron tomentosum*
- *Genista* e.g. *G. pilosa*. See harris below.
- *Sambucus ebulus*

Shrub & tree layers:

- **Raspberry** – (*Rubus idaeus*).
- **Blackberries** - all blackberry species including *Corylifolii* and *Rubus caesius*, e.g. *Rubus nessensis*, *R. plicatus* and *R. radula*.
- Roses - (*Rosa*), e.g. *R. majalis* of which *majalis/foecundissima*, *R. rugosa*, *R. dumalis*, syn. *R. canina*, *R. afzeliana* and *R. villosa* subspecies *Mollis / villosa*.
- *Potentilla fruticosa*
- *Myrica gale*
- *Betula nana*
- *Hedera helix*
- *Lonicera periclymenum*
- *Viburnum opulus*
- *Solanum dulcamara*
- *Chamedaphne calyculata*
- *Cytisus scoparius*

Is a species unusual in the area registered, i.e. registered on less than 0.25% of the sample areas in the last 10 years, a warning triangle is obtained in the list (see in front of *Trifolium medium* in figure 12.3.1.1 above). In addition, the registration appears as a warning during the sample plot test (section 2.12).

## 12.3.2 LIST OF SPECIES IN SYSTEMATIC ORDER

Species/species groups that are included in any cover assessment (in addition to the cover groups "Remaining lichens", "Remaining bryophytes" and "Remaining field vegetation layers") are marked with a number of symbols:

|            |   |                            |            |   |  |
|------------|---|----------------------------|------------|---|--|
| <b>HOT</b> | = | <i>tall ferns</i>          | <b>LT</b>  | = | <i>lycophyte</i>                           |
| <b>BT</b>  | = | <i>broadleaved grass</i>   | <b>RTH</b> | = | <i>reindeer lichens</i> (cover and height) |
| <b>ST</b>  | = | <i>narrow-leaved grass</i> | <b>ET</b>  | = | <i>EFLH Group</i>                          |
| <b>KT</b>  | = | <i>Melampyrum species</i>  | <b>T</b>   | = | <i>all others</i>                          |

"all others" usually represents a single species or group of species.

All species/species groups that do not have a symbol are included in one of the Remaining groups (see above). The RIS species handbook states what is included in the various cover groups.

### Species list

|                         |
|-------------------------|
| Species                 |
| Cetraria spp.           |
| Cladonia spp.           |
| Cladina stellaris       |
| Cladina spp.            |
| Stereocaulon spp.       |
| Nephroma arcticum       |
| Peltigera aphthosa      |
| Peltigera spp.          |
| Other lichens           |
| Plagiochila asplenoides |
| Sphagnum spp.           |
| Polytrichum commune     |
| Dicranum spp.           |

12.3.2 Soil vegetation description - Registration of occurrence  
List of species in systematic order

|   |
|---|
| Rhodobryum roseum                         |
| Minum spp.                                |
| Climacium dendroides                      |
| Aulacomnium palustre                      |
| Ptilium crista-castrensis                 |
| Rhytidiadelphus triquetrus                |
| Pleurozium schreberi                      |
| Hylocomnium splendens                     |
| Other mosses 2008                         |
| Huperzia selago                           |
| Lycopodium annotinum                      |
| Lycopodium clavatum                       |
| Diphasiastrum complanatum                 |
| Selaginella selaginoides                  |
| Equisetum hyemale                         |
| Equisetum arvense                         |
| Equisetum pratense                        |
| Equisetum palustre                        |
| Equisetum fluviatile                      |
| Equisetum sylvaticum                      |
| Pteridium aquilinum                       |
| Thelypteris palustris                     |
| Phegopteris connectilis                   |
| Athyrium filix-femina & distentifolium    |
| Matteuccia struthiopteris                 |
| Dryopteris filix-mas                      |
| Dryopteris carthusiana & dilata & expansa |
| Gymnocarpium dryopteris                   |
| Polypodium vulgare                        |
| Urtica dioica                             |
| Bistorta vivipara                         |
| Rumex coll.                               |
| Rumex acetosa                             |
| Rumex acetosella                          |

12.3.2 Soil vegetation description - Registration of occurrence  
List of species in systematic order

|                       |
|-----------------------|
| Moehringia trinervia  |
| Stellaria nemorum     |
| Stellaria holostea    |
| Stellaria graminea    |
| Silene dioica         |
| Aconitum lycoctonum   |
| Anemone nemorosa      |
| Anemone ranunculoides |
| Hepatica nobilis      |
| Actaea spp.           |
| Trollius europaeus    |
| Caltha palustris      |
| Ranunculus coll.      |
| Ranunculus ficaria    |
| Corydalis spp.        |
| Dentaria bulbifera    |
| Drosera spp.          |
| Crassulaceae          |
| Saxifraga granulata   |
| Chrysosplenium spp.   |
| Parnassia palustris   |
| Filipendula vulgaris  |
| Filipendula ulmaria   |
| Rubus chamaemorus     |
| Rubus arcticus        |
| Rubus saxatilis       |
| Geum rivale           |
| Geum urbanum          |
| Potentilla palustris  |
| Potentilla anserina   |
| Potentilla erecta     |
| Fragaria spp.         |
| Alchemilla spp.       |
| Lupinus spp.          |
| Vicia spp.            |

12.3.2 Soil vegetation description - Registration of occurrence  
List of species in systematic order

|   |
|---|
| Lathyrus vernus   |
| Lathyrus linifolius                                       |
| Trifolium repens  |
| Trifolium medium  |
| Trifolium pratense  |
| Lotus corniculatus  |
| Fabaceae  |
| Oxalis acetosella   |
| Geranium sylvaticum                                       |
| Mercurialis perennis                                      |
| Hypericum spp.  |
| Viola palustris & epipsila                                |
| Viola mirabilis   |
| Viola riviniana & canina &<br>reichenbachiana & rupestris |
| Viola tricolor & arvensis                                 |
| Epilobium angustifolium                                   |
| Epilobium montanum & collinum                             |
| Cornus suecica  |
| Sanicula europaea   |
| Anthriscus sylvestris                                     |
| Aegopodium podagraria                                     |
| Angelica sylvestris                                       |
| Peucedanum palustre                                       |
| Orthilia secunda  |
| Moneses uniflora  |
| Erica tetralix  |
| Calluna vulgaris  |
| Ledum palustre  |
| Andromeda polifolia                                       |
| Vaccinium oxycoccus & microcarpum                         |
| Vaccinium vitis-idaea                                     |
| Vaccinium myrtillus                                       |
| Vaccinium uliginosum                                      |
| Arctostaphylos uva-ursi                                   |

12.3.2 Soil vegetation description - Registration of occurrence  
List of species in systematic order

|                                |
|--------------------------------|
| Empetrum nigrum                |
| Primula veris                  |
| Lysimachia vulgaris            |
| Lysimachia thyrsoflora         |
| Trientalis europaea            |
| Menyanthes trifoliata          |
| Galium boreale                 |
| Galium odoratum                |
| Galium verum                   |
| Pulmonaria spp.                |
| Galeopsis spp.                 |
| Lamium galeobdolon             |
| Stachys sylvatica              |
| Scrophularia nodosa            |
| Veronica chamaedrys            |
| Veronica officinalis           |
| Melampyrum pratense            |
| Melampyrum sylvaticum          |
| Euphrasia spp.                 |
| Pedicularis sceptrum-carolinum |
| Pedicularis palustris          |
| Pinguicula spp.                |
| Plantago major                 |
| Linnaea borealis               |
| Valeriana spp.                 |
| Succisa pratensis              |
| Campanula spp.                 |
| Solidago virgaurea             |
| Gnaphalium spp.                |
| Antennaria dioica              |
| Achillea ptarmica              |
| Achillea millefolium           |
| Matricaria perforata           |
| Leucanthemum vulgare           |
| Tanacetum vulgare              |

12.3.2 Soil vegetation description - Registration of occurrence  
List of species in systematic order

|                                |
|--------------------------------|
| Artemisia vulgaris             |
| Tussilago farfara              |
| Petasites frigidus             |
| Arnica montana                 |
| Senecio spp.                   |
| Saussurea alpina               |
| Cirsium arvense                |
| Cirsium vulgare                |
| Cirsium palustre               |
| Cirsium helenioides            |
| Hypochoeris maculata           |
| Cicerbita alpina               |
| Mycelis muralis                |
| Taraxacum spp.                 |
| Crepis paludosa                |
| Scheuchzeria palustris         |
| Tofieldia pusilla              |
| Narthecium ossifragum          |
| Gagea spp.                     |
| Allium ursinum                 |
| Convallaria majalis            |
| Maianthemum bifolium           |
| Paris quadrifolia              |
| Polygonatum spp.               |
| Juncus filiformis              |
| Juncus conglomeratus & effusus |
| Luzula campestris              |
| Luzula multiflora              |
| Luzula pilosa                  |
| Other Juncaceae & Luzula       |
| EFLH-t*                        |
| Poa nemoralis                  |
| Melica nutans                  |
| Deschampsia cespitosa          |
| Deschampsia flexuosa           |



12.3.2 Soil vegetation description - Registration of occurrence  
List of species in systematic order

|                                    |
|------------------------------------|
| Anthoxanthum odoratum              |
| Agrostis capillaris                |
| Calamagrostis canescens & purpurea |
| Calamagrostis arundinacea          |
| Milium effusum                     |
| Phragmites australis               |
| Molinia caerulea                   |
| Nardus stricta                     |
| Other Poaceae (narrow leaf)        |
| Other Poaceae (broad leaf)1993     |
| Calla palustris                    |
| Typha spp.                         |
| Scirpus sylvaticus                 |
| Trichophorum alpinum               |
| Trichophorum cespitosum            |
| Eriophorum angustifolium           |
| Eriophorum vaginatum               |
| Rhynchospora alba                  |
| Carex chordorrhiza                 |
| Carex echinata                     |
| Carex lasiocarpa                   |
| Carex rostrata                     |
| Carex panicea & vaginata           |
| Carex flava-gruppen                |
| Carex digitata                     |
| Carex globularis                   |
| Carex magellanica & limosa         |
| Carex pauciflora                   |
| EFLH-h*                            |
| Other Cypraceae                    |
| Listera ovata                      |
| Listera cordata                    |
| Goodyera repens                    |
| Platanthera coll.                  |
| Dactylorhiza maculata              |

12.3.2 Soil vegetation description - Registration of occurrence  
List of species in systematic order

|                                   |
|-----------------------------------|
| Corallorhiza trifida              |
| Other Fieldlayer species          |
| Picea abies                       |
| Larix spp.                        |
| Abies spp.                        |
| Pinus sylvestris                  |
| Pinus contorta                    |
| Juniperus communis                |
| Taxus baccata                     |
| Other coniferous trees and bushes |
| Salix spp.                        |
| Populus tremula                   |
| Myrica gale                       |
| Betula pendula                    |
| Betula pubescens                  |
| Betula nana                       |
| Alnus glutinosa                   |
| Alnus incana                      |
| Corylus avellana                  |
| Carpinus betulus                  |
| Fagus sylvatica                   |
| Quercus robur & petraea           |
| Ulmus spp.                        |
| Ribes spicatum                    |
| Ribes nigrum                      |
| Ribes alpinum                     |
| Rubus idaeus                      |
| Rubus fruticosus agg.             |
| Rosa spp.                         |
| Malus spp.                        |
| Sorbus aucuparia                  |
| Sorbus coll.                      |
| Crataegus spp.                    |
| Prunus spinosa                    |
| Prunus avium & cerasus            |

12.3.2 Soil vegetation description - Registration of occurrence  
List of species in systematic order

|                                      |
|--------------------------------------|
| Prunus padus & serotina & virginiana |
| Acer platanoides                     |
| Acer pseudoplatanus                  |
| Frangula alnus                       |
| Tilia spp.                           |
| Daphne mezereum                      |
| Fraxinus excelsior                   |
| Sambucus nigra & racemosa            |
| Viburnum opulus                      |
| Lonicera xylosteum                   |
| Other deciduous trees & bushes       |
| "Brown" mosses                       |
| Other Carex                          |

## 12.4 ASSESSMENT OF COVER RATIO



### 12.4.1 GENERAL

[menu] Vegetation menu ,  
the submenus cover bottom layer, cover field vegetation layer and cover raspberries]

Assessment of cover is performed in three different menus; cover bottom layer, cover field vegetation layer and cover raspberries. These menus include the following items:

- Registration of cover ratio for the selection of the species/species groups in the list of species in each layer registered in the Occurrence menu.

In addition:

- Registration of degree of cover of bottom layer is absent (BSA), in the menu cover bottom layer.
- Registration of field vegetation layer cover is absent (FSAK), in menu field vegetation layer cover.

The registration of occurrence is the basis for the list of species/species groups that are to be assessed for cover. The cover assessment is therefore performed after the occurrence registration has been completed.

## 12.4.2 COVER ASSESSMENT

Assessment of cover on the 5.64 m plot refers to:

- cover at full development; i.e. the maximum cover of the species/species group at some point during the current vegetation period.
- All above-ground, living parts of the plant; where applicable, also wooded trunks and branches. (Dead plant parts can sometimes serve as guidance for assessing full development.)
- The cover is viewed vertically from above. The projection of the plants on the ground surface should be estimated, i.e. the shadow the plants would cast on the ground if they were illuminated from above with parallel light beams. This is the net cover in question - excluding spaces in the foliage. Referred to as "strict cover" in Appendix B8.
- The different species/species groups are assessed for cover separately. Cover is thus counted between the species/species groups, but not within the species/species groups.

Cover is registered in m<sup>2</sup> classes ("top" classes, see section 12.2).

Assessing plant cover must be learned practically and practiced a lot. This is especially important on sample plots that are as large as these, where immediate overview at a glance is not possible.

### 12.4.3 LIST OF SPECIES FOR REGISTRATION OF COVER

This section lists the species/species groups that are to be assessed for cover in each layer. The *RIS Species Manual* provides some information about the grounds for the selection, as well as definitions of the groups' content.

The abbreviations used are:

|      |  |
|------|--|
| fam. | Family.  |
| gen. | Genus.   |
| spp. | Here, <u>all the species within the genus</u> (see <i>RIS Species Manual</i> page 8) - there are two exceptions; see <i>cranberry spp.</i> and <i>Sorbus intermedia spp.</i> |
| ssp. | Subspecies. Note! → <i>Please do not confuse with spp. above!</i>  |
| syn. | Swedish or Latin name used synonymously (e.g. old terms that "stick around").  |
| var. | Variety.   |



List of the species/species groups in the **bottom layer** that must be assessed for cover:

- **Bottom layer absent (BSA).**

*Lichen:*

- Lichen spp. (sl. *Cladonia*).
- Reindeer lichen spp. (Sl. *Cladina*). → Height is also assessed for this species group (see section 12.5).
- Lichen spp. (Sl. *Stereocaulon*).
- **Remaining lichen.** All other lichen that are not included in any of the above listed species groups.

*Bryophite:*

- **Bryophite spp.** (Sl. *Sphagnum*).
- ***Polytrichum commune*.**
- ***Scorpidium spp.*** Definition, see section 5.2 under bottom layer wetland mosses.
- ***Pleurozium schreberi*.**
- ***Hylocomium splendens*.**
- **Remaining bryophite.** All other bryophite not included in the above listed species/species groups.

List of the species/species groups in the field vegetation layer to be assessed for cover:

- **Field vegetation layer absent** (FSAK).
- **Lycophyte** (fam. *Lycopodiaceae*).
  - *Selaginella selaginoides* not included! See also note under **Remaining field vegetation layer!**
- *Equisetum sylvaticum*.
- *Pteridium aquilinum*, ssp. *latiusculum/aquilinum*.
- *Phegopteris connectilis*, syn. *Thelypteris/Dryopteris/Lastrea phegopteris*.
- **Tall ferns.**

This group includes (as in the previous site mapping) only those 'tall ferns' that have an oval lanceolate leaf shape and grow in a rosette arrangement. Examples of such species include *Athyrium filix-femina* and *A. distentifolium*, syn. *A. alpestre*, *Matteuccia struthiopteris*, syn. *Struthiopteris filicastrum*, *Dryopteris filix-mas*, *D. cristata*, *Polystichum lonchitis* and *Oreopteris limbosperma*.

Examples of non-approved species are *Dryopteris carthusiana*, syn. *D. spinulosa*, *D. dilatata*, syn. *D. austriaca* and *D. expansa*, syn. *D. assimilis* and *Thelypteris palustris*, syn. *Dryopteris/Lastrea thelypteris*.
- **Ekbräken** (*Gymnocarpium dryopteris*, syn. *Dryopteris linneana*, *Lastrea dryopteris*).
- **Brännässla** (*Urtica dioica*, ssp. *dioica/sondenii/gracilis*).



- **Ängssyra** (*Rumex acetosa*, ssp. *acetosa/lapponicus*; var. *serpentinicola*).
- **Lundarv** syn. lundstjärnblomma (*Stellaria nemorum*, ssp. *Nemorum/glochidisperma*).
- **Buskstjärnblomma** (*Stellaria holostea*).
- **Rödblära** (*Silene dioica*, syn. *Melandrium dioicum/rubrum*).
- **Nordisk stormhatt** (*Aconitum lycoctonum*, syn. *A. septentrionale*).
- **Vitsippa** (*Anemone nemorosa*).
- **Gulsippa** (*Anemone ranunculoides*).
- **Blåsippa** (*Hepatica nobilis*, syn. *Anemone hepatica*).
- **Trolldruva spp.** Svart trolldruva, syn. trolldruva (*Actaea spicata*) och röd trolldruva (*A. erythrocarpa*).
- **Smörboll** syn. daldocka (*Trollius europaeus*).
- **Tandrot** (*Dentaria bulbifera*).
- **Älggräs** syn. älgört, mjödört (*Filipendula ulmaria*).
- **Hjortron** (*Rubus chamaemorus*).
- **Humleblomster** (*Geum rivale*).
- **Harsyra** (*Oxalis acetosella*).
- **Skogsnäva** syn. midsommarblomster (*Geranium sylvaticum*)(Högört i region 1-3).
- **Skogsbingel** (*Mercurialis perennis*).
- **Mjölkört** syn. mjölke, rallarros (*Epilobium angustifolium*, syn. *Chamaenerion angustifolium*).
- **Sårläka** (*Sanicula europaea*).

- **Hundkäk** syn. hundloka (*Anthriscus sylvestris*).
- **Kirskål** syn. kers (*Aegopodium podagraria*).
- **Strätta** syn. skogskvanne (*Angelica sylvestris*).
- **Klockljung** (*Erica tetralix*).
- **Ljung** (*Calluna vulgaris*).
- **Skvattram** syn. getpors (*Ledum palustre*, syn. *Rhododendron tomentosum*).
- **Rosling** (*Andromeda polifolia*).
- **Tranbär spp.** tranbär (*Vaccinium oxycoccus*, syn. *Oxycoccus quadripetalus*) och dvärgtranbär (*V. microcarpum*, syn. *Oxycoccus microcarpus*). Obs! Ej hela släktet (*Vaccinium*).
- **Lingon** (*Vaccinium vitis-idaea*).
- **Blåbär** (*Vaccinium myrtillus*).
- **Odon** (*Vaccinium uliginosum* ssp. *uliginosum/alpinum*).
- **Mjölön** (*Arctostaphylos uva-ursi*).
- **Kråkbär** (*Empetrum nigrum* ssp. *nigrum/hermaphroditum*).
- **Vattenklöver** (*Menyanthes trifoliata*).
- **Myska** syn. myskmadra (*Galium odoratum*, syn. *Asperula odorata*).
- **Gulplister** (*Lamiastrum galeobdolon*, ssp. *galeobdolon/argentatum*, syn. *Lamium galeobdolon*).
- **Stinksyska** (*Stachys sylvatica*).
- **Ängs-/skogskovall**. Ängskovall (*Melampyrum pratense*) och skogskovall (*M. sylvaticum*).
- **Kärrtistel** (*Cirsium palustre*).

- **Borsttistel** syn. brudborste (*Cirsium helenioides*, syn. *C. heterophyllum*).
  - **Torta** syn. toltta, fjälltolta, älgkål (*Cicerbita alpina*, syn. *Lactuca alpina*, *Mulgedium alpinum*).
  - **Skogssallat** (*Mycelis muralis*, syn. *Lactuca muralis*).
  - **Kärrfibbla** (*Crepis paludosa*, syn. *Aracium paludosum*).
  - **Ramslök** (*Allium ursinum*).
  - **Ekorrbär** (*Maianthemum bifolium*).
  - **Ormbär** (*Paris quadrifolia*).
  - **Broad-leaved grass** (entire species *Poaceae* except small-leaved, see below).
  
  - **Small-leaved grass.** This group includes all grass species with filamentous leaves that are usually sapless and densely clustered lengthwise:
    - *Deschampsia flexuosa*, syn. *Aira flexuosa*
    - *Festuca ovina*, syn. ssp. *capillata*, syn. *F. capillata* and *Festuca rubra*-group, e.g: *F. rubra*, *F. stricta*, *F. heterophylla* and *F. pulesica*.
    - *Nardus stricta*.
    - *Corynephorus canescens*.
  
  - **Klotstarr** (*Carex globularis*).
  - **EFLH** Non-moisture-absorbing low-growing *Cyperaceae* and *Juncaceae*.
- The most common species are:
- **vårfryle** (*Luzula pilosa*),
  - **knippfryle** (*L. campestris*, syn. *L. vulgaris*),

- **ängsfryle** (*L. multiflora* ssp. *multiflora/frigida*),
- **blekfryle** (*L. pallescens*),
- **vispstarr** (*Carex digitata*),
- **pillerstarr** (*C. pilulifera*),
- **vår-/back-/lundstarr** (*C. caryophyllea*, syn. *C. praecox/-C. ericetorum/C. montana*),
- **blekstarr** (*C. pallescens*) och
- **snårstarr-gruppen** (piggstarr (*C. spicata*, syn. *C. contigua*), snårstarr (*C. muricata*, spp. *lamprocarpa/muricata*, syn. *C. pairaei*) och långstarr (*C. divulsa*, syn. *leersii*)).

The group also includes the following (less common) species:

**Juncaceae:**

*L. spicata*, *L. luzuloides*, syn. *L. nemorosa/albida*  
and *Juncus trifidus*.

**Cyperaceae:**

*Carex arenaria* (including *Carex colchica*) and other species within the *Carex digitata*- group. *C. areanaria* (including *C. ligerica*) and (*C. pallens*, *C. ornithopoda* and *C. pediformis*, syn. *C. rhizina*).

- **Tvåblad** (*Listera ovata*).

**Remaining field vegetation layer.**

- *Keep in mind the distinction between the field vegetation layer and the shrub & tree layer, so that species belonging to the latter layer are not included in this group, see section 12.3.1.*
- *Also keep in mind that the stratification is completely fixed to species; a spruce seedling thus also belongs to the shrub & tree layer and should not be included in the remaining field vegetation layer.*

In the **shrub & tree layer**, only one species should be assessed for cover:

- *Rubus idaeus*.



## 12.5 ASSESSMENT OF REINDEER LICHEN HEIGHT

**Reindeer lichen height** [menu Directions, submenu Reindeer lichen height]

5.64 m-surface

A value for the variable Reindeer lichen height should be recorded when the presence of *Cladina stellaris* and/or Other reindeer lichen (other in sl. *Cladina*) have been registered. Area-weighted average height of the cover group Reindeer lichen spp. is referred to. For example, if 80 % of the area covered by Reindeer lichen spp. is 1 cm tall and 20 % of the area is 5 cm, the area-weighted average height is  $(0.8 \cdot 1) + (0.2 \cdot 5) = 1.8$  cm, which means the code "2" is registered. Valid codes are 0-20 cm. Height is measured from the ground level, see p. 11:24.

Code Reindeer lichen height (cm)

|     |                  |
|-----|------------------|
| 00  | > 0.0 -- ≤ 0.5   |
| 01  | > 0.5 -- ≤ 1.5   |
| 02  | > 1.5 -- ≤ 2.5   |
| ... | ...              |
| 19  | > 18.5 -- ≤ 19.5 |
| 20  | > 19.5           |